

DRY-PIPE, DELUGE, PREACTION VALVES & ACCESSORIES

Table of Contents

	Page
1.0 SCOPE	9
2.0 DRY-PIPE VALVES	9
2.1 Automatic (ASCOA) Model A	9
2.2 Automatic (ASCOA) Models B, B-2, and 39	11
2.3 Central Model AD	16
2.4 Chemetron "Star" Models F and G	19
2.5 Crowder Model A	24
2.6 FPC Models A and B	26
2.7 Globe Models 4, 5, and 6	28
2.8 Globe Model B	30
2.9 Grimes Model A	43
2.10 Grimes Model B	47
2.11 Grinnell Models A and A-2	49
2.12 Grinnell Model D	55
2.13 Grinnell Models F302 and F3021	60
2.14 Grinnell Straightway Model B	63
2.15 Grinau Model A	64
2.16 Hodgman Model A	68
2.17 Hodgman Model C	71
2.18 KME Model A	74
2.19 Manufacturers Model 3	79
2.20 Matthew Hall Model MK II	82
2.21 Niagara Model G D	84
2.22 Preussag Model TAV-FM	88
2.23 Reliable Models B, C, C-1, C-2, and D	91
2.24 Rockwood Models A and B	97
2.25 Rockwood Model C	99
2.26 Standard Model A	105
2.27 Star Model A	108
2.28 Star Model D	113
2.29 Viking Models C, C-2, C-3, and D-1	115
2.30 Viking Tyden Models A and B	118
3.0 EXHAUSTERS AND ACCELERATORS	121
3.1 Automatic (ASCOA) Model 1 Accelerator	121
3.2 Automatic (ASCOA) Model 185 Accelerator	123
3.3 Automatic (ASCOA) Model A Exhauster	126
3.4 Automatic (ASCOA) Model B Exhauster	129
3.5 Central Lewis Model A Exhauster	132
3.6 Central Model AD Accelerator	135
3.7 FPC Models A and B Accelerators	137
3.8 Globe Model A Exhauster-Adaptor	140
3.9 Globe Model B Exhauster	142
3.10 Globe Model B Accelerator	144
3.11 Globe Model B Electroac Valve	147

2-10R Dry-Pipe, Deluge, Preaction Valves & Accessories

3.12 Globe Model C Quick-Opening Device	150
3.13 Globe Model D Accelerator	154
3.14 Grimes Model AB Accelerator	157
3.15 Grinnell Models A1, A2, A3, A4, A5, A6 Accelerators	159
3.16 Reliable Automatic Model A Accelerator	162
3.17 Reliable Model B Accelerator	165
3.18 Rockwood Model C Exhauster	166
3.19 Rockwood Model A Exhauster	169
3.20 Standard Model A Accelerator	171
3.21 Star Models A, AA, B, BB Exhausters	173
3.22 Viking Tyden Model A Accelerator	176
3.23 Viking Tyden Model A Exhauster	178
3.24 Viking Tyden Model B Accelerator	181
3.25 Viking Tyden Model B Exhauster	184
3.26 Viking Tyden Model C Air Pressure Maintenance Device	186
4.0 DELUGE AND PREACTION SYSTEMS	188
4.1 Automatic (ASCOA) Model 142 (Suprotex)	188
4.2 Automatic (ASCOA) Model A	195
4.3 Automatic (ASCOA) Model C (Suprotex, Multitrol, Dualguard)	201
4.4 Central Model AD	212
4.5 Grinnell Model B	219
4.6 Grinnell Multimatic Deluge and Preaction System	223
4.7 Grinnell Protomatic Release Model F100	231
4.8 Hodgman Model A	245
4.9 Reliable Model B (Supertrol)	250
4.10 Rockwood Model K-2	259
4.11 Star Electromatic Model D	261
4.12 Star Model F Hidromatic	266
4.13 Star Model G Hidromatic	271
4.14 Viking Firecycle Sprinkler System	282
4.15 Viking Model D, D2, D3, D4	298

List of Figures

Fig.1. "Automatic" dry-pipe Model A	9
Fig. 2. "Automatic" dry-pipe Model A	10
Fig. 3. "Automatic" Model B dry-pipe valve with original clapper.	11
Fig. 4. "Automatic" Model B-2 dry-pipe valve.	12
Fig. 5. "Automatic" Model B-2 dry-pipe valve trim.	13
Fig. 6. "Automatic" Model 39 dry-pipe valve, internal view.	14
Fig. 7. "Automatic" Model 39 dry-pipe valve trim.	14
Fig. 8. Sectional View of Central "AD" Dry-Pipe Valve in Normal Closed Position	16
Fig. 9. Trimmings for 6-Inch Central "AD" Dry-Pipe Valve	17
Fig. 10. Automatic Float Drain for Use with 6-Inch Central "AD" Dry-Pipe Valve	17
Fig. 11. Sectional view of Central Model C Dry-Pipe Valve in normal closed position.	19
Fig. 12. Central Model C dry-pipe valve with Model AD accelerator and connections.	20
Fig. 13. Star Model F dry-pipe valve.	21
Fig. 14. Trim on Star Model F dry-pipe valve.	23
Fig. 15. Crowder Model A dry-pipe valve.	24
Fig. 16. Crowder Model A dry-pipe valve as installed, with trim.	25
Fig. 17. FPC Model A dry-pipe valve.	27
Fig. 18. FPC Model A dry-pipe valve as installed, with trim.	28
Fig. 19. Globe dry-pipe valve in closed or dry position.	29
Fig. 20. Globe dry-pipe valve in open or wet position.	30
Fig. 21. Globe dry-pipe valve as installed with trim.	31
Fig. 22. Model B, in the dry position.	32
Fig. 23. Model B, external view.	33
Fig. 24. Model D 6-inch (152-mm), in dry position.	34

Dry-Pipe, Deluge, Preaction Valves & Accessories 2-10R

Fig. 25. Model D, equipped with electroac quick opening device, external view.	34
Fig. 26. Model AD 6-inch (152-mm), in the wet position.	36
Fig. 27. Automatic air pressure maintenance device, connected to Model AD dry-pipe valve.	37
Fig. 28. Modifications to Models D and AD Valves Dry Position.	38
Fig. 29. Models F and F-2 Valves in the Dry Position.	41
Fig. 30. Model F, external view.	42
Fig. 31 - Model A - Internal View	44
Fig. 32 - Model A - External View	45
Fig. 33. Grinnell No. 12 dry pipe valve	46
Fig. 34. Grinnell No. 12 dry pipe valve	47
Fig. 35. Grimes Model B Dry-Pipe Valves	48
Fig. 36. Grimes Model B Dry-Pipe Valves	49
Fig. 37. Grimes Model B Dry-Pipe Valves	50
Fig. 38. Grinnell dry-pipe valve Model A.	51
Fig. 39. Grinnell dry-pipe valve Model A-2.	52
Fig. 40. Grinnell Model A and A-2 dry-pipe valve trim.	53
Fig. 41. Grinnell Model A dry-pipe valve, internal view.	53
Fig. 42. Grinnell Model A Dry-pipe valve trim.	54
Fig. 43. Model D, internal view.	55
Fig. 44. Model D, external view.	56
Fig. 45. Model E, internal view.	57
Fig. 46. Models E-2 and F-300, internal view.	58
Fig. 47. Dry-pipe valve as installed with trim.	59
Fig. 48. Model F302 and Model F3021 dry-pipe valves.	60
Fig. 49. Basic trimmings for Model F302 and Model F3021 dry-pipe valves.	61
Fig. 50. Straightway Model B - Internal View.	63
Fig. 51. Straightway Model B - External View.	65
Fig. 52. Grunau Model A dry-pipe valve.	66
Fig. 53. Grunau dry-pipe valve trim.	67
Fig. 54. Hodgman dry-pipe valve, internal view.	68
Fig. 55. Hodgman dry-pipe valve trim.	69
Fig. 57. Hodgman dry-pipe valve trim.	71
Fig. 58. Hodgman Model C dry-pipe valve.	72
Fig. 59. Trim on Hodgman Model C dry-pipe valve.	73
Fig. 60. K.M.E. dry-pipe valve Model A.	75
Fig. 61. K.M.E. dry-pipe valve Model A.	76
Fig. 62. Lewis dry-pipe valve Model B, internal view.	77
Fig. 63. Lewis dry-pipe valve Model B trim.	78
Fig. 64. Manufacturers Model 3 dry-pipe valve, internal views.	80
Fig. 65. Manufacturers Model 3 dry-pipe valve trim.	81
Fig. 66. Mathew Hall MK 11 dry-pipe valve.	82
Fig. 67. Trigger mechanism.	83
Fig. 68. Schematic of installation.	85
Fig. 69. Niagara Model G dry-pipe valve, internal views	86
Fig. 70. Niagara Model G dry-pipe valve, with trim	87
Fig. 71. Air check valve showing special cover with internal stop for air clapper (Model E made after March 1909 and Models EE, F, and G dry-pipe valves).	89
Fig. 72. Preussag Model TAV-FM dry-pipe valve.	90
Fig. 73. Trim on Preussag Model TAV-FM dry-pipe valve.	91
Fig. 74. Reliable Model D Dry-pipe valve.	92
Fig. 75. Reliable Model D dry-pipe valve, cross section	93
Fig. 76. Trim on Reliable Model D dry-pipe valve	94
Fig. 77. Reliabel Model B dry-pipe valve.	95
Fig. 78. Reliable Model B dry-pipe valve as installed with trim.	96
Fig. 79. Reliable Model C dry-pipe valve.	97
Fig. 80. Reliable Model C, as installed with trim.	98
Fig. 81. Rockwood dry-pipe valves, Model A and Model B, internal views.	99
Fig. 82. Rockwood dry-pipe valve trim.	100

2-10R Dry-Pipe, Deluge, Preaction Valves & Accessories

Fig. 83. Rockwood Model C dry-pipe valve.	101
Fig. 84. Rockwood Model C dry-pipe valve, as installed with trim.	102
Fig. 85. Rockwood Model D dry-pipe valve.	103
Fig. 86. Rockwood Model D dry-pipe valve, as installed with trim.	104
Fig. 87. Standard Dry Pipe Valve, Model A.	106
Fig. 88. Side View of Standard Model A dry pipe valve as installed with various trimmings.	107
Fig. 89. Star Model A dry-pipe valve. (a) cross section of valve. (b) valve as installed with trim.	109
Fig. 90. Star Model B (and C) dry-pipe valve	110
Fig. 91. Star Model B (and C) dry-pipe valve	111
Fig. 92. Star Model B (and C) dry-pipe valve	112
Fig. 93. Closed (Set Dry) Position of Parts.	113
Fig. 94. Front and Rear Views.	114
Fig. 95. Viking dry-pipe valve.	116
Fig. 96. Viking Tyden Models A and B dry-pipe valves.	117
Fig. 97. Viking Tyden Models A and B trim.	118
Fig. 98. Viking Model A dry-pipe valve, internal view.	119
Fig. 99. Viking Model A dry-pipe valve with trim.	120
Fig. 100. "Automatic" accelerator Model 1, internal view	121
Fig. 101. "Automatic" accelerator Model 1 trim.	122
Fig. 102. "Automatic" Model 185 accelerator components	124
Fig. 103. "Automatic" Model 185 accelerator in operation.	125
Fig. 104. "Automatic" Model 185 accelerator trim.	125
Fig. 105. "Automatic" exhauster Model A. A, internal view; B, close-up of restriction assembly.	127
Fig. 106. "Automatic" exhauster, Model A trim.	128
Fig. 107. Exhauster adapter with "Automatic" Model A exhauster.	129
Fig. 108. Automatic Model B exhauster.	130
Fig. 109. Automatic exhauster trim.	131
Fig. 110. Lewis Model A exhauster, internal view.	133
Fig. 111. Lewis Model A exhauster trim.	134
Fig. 112. Central Dry-Pipe Accelerator Model AD	136
Fig. 113. F.P.C. Accelerator Model B, internal view (made after 1955).	137
Fig. 114. F.P.C. Accelerator Model B trim.	139
Fig. 115. Globe Model A exhauster-adapter, internal view.	140
Fig. 116. Globe Model A exhauster-adapter trim.	141
Fig. 117. Globe Model B exhauster, internal view.	142
Fig. 118. Globe Model B exhauster trim.	143
Fig. 119. Globe Model B accelerator, internal views.	145
Fig. 120. Globe Model B accelerator trim.	146
Fig. 121. Globe Electroac Quick-Opening Device showing Solenoid E and Air By-Pass Valve Assembly (6) with Globe Model D Dry Pipe Valve.	148
Fig. 122. Model B Electroac Valve attached to Globe D Dry Pipe Valve.	149
Fig. 123. Mercury Switch.	150
Fig. 124. Globe Dry-Pipe Quick Opening Device - Model C	151
Fig. 125. Globe dry-pipe accelerator - Model C	153
Fig. 126. Automatic drip valve	153
Fig. 127. Globe accelerator Model D. A, side view; B, front view.	154
Fig. 128. Globe accelerator Model D trim.	155
Fig. 129. Close-up of accelerator, priming cup, and priming valve.	156
Fig. 130. Grimes Model AB dry-pipe accelerator.	157
Fig. 131. Cross section of accelerator.	159
Fig. 132. Cross section of accelerator showing connection to air side of dry-pipe valve.	159
Fig. 133. Accelerator installed to Models C and D dry-pipe valves.	160
Fig. 134. Automatic drip valve.	161
Fig. 135. Special drip valve used when accelerator is attached to Models C and D dry-pipe valves.	161
Fig. 136. Reliable Automatic Model A accelerator, internal view.	162
Fig. 137. Reliable Automatic Model A accelerator trim.	164
Fig. 138. Reliable Model B Accelerator.	165
Fig. 139. Rockwood exhauster Model C, internal view.	167

Dry-Pipe, Deluge, Preaction Valves & Accessories 2-10R

Fig. 140. Rockwood exhauster Model C trim.	168
Fig. 141. Rockwood exhauster Model A, internal view.	170
Fig. 142. Rockwood exhauster Model A trim.	171
Fig. 143. Standard Model A Accelerator	172
Fig. 144. Star Models A, AA, B, BB Exhausters	173
Fig. 145. Star exhausters	175
Fig. 146. Tyden Model A accelerator, internal view.	176
Fig. 147. Tyden Model A accelerator trim	177
Fig. 148. Tyden Model A exhauster, internal view	179
Fig. 149. Tyden Model A exhauster trim	180
Fig. 150. Tyden Model B accelerator, internal view.	182
Fig. 151. Tyden Model B accelerator trim.	183
Fig. 152. Tyden Model B exhauster, internal view	185
Fig. 153. Tyden Model B exhauster trim.	186
Fig. 154. Viking Tyden Model C Air Pressure Maintenance Device	187
Fig. 155. "Automatic" Water Control Valve Model 142.	189
Fig. 156. 6-Inch "Automatic" Water Control Valve Model 142 — External View.	190
Fig. 157. Details of Action of Mercury Checks (Diagrammatic)	191
Fig. 158. Schematic drawing of Model A automatic water control valve and piping connections.	196
Fig. 159. Automatic water control valve Model A - details of valve.	197
Fig. 160. Automatic water control valve Model A — piping arrangement at the valve.	199
Fig. 161. "Automatic" Water Control Valve Model C	203
Fig. 162. Supervisory Air Pump. Hydraulically Operated. Diaphragm Controlled.	205
Fig. 163. Air Filter (79-320A).	206
Fig. 164. Air Line Restriction (79-850).	206
Fig. 165. Air Line Mercury Check (79-840).	207
Fig. 166. Anti-Flooding Valve (105-100).	207
Fig. 167. Action of Mercury Checks Supplied Prior to 1941 (Diagrammatic).	209
Fig. 168. Action of Mercury Checks Supplied After 1941 (Diagrammatic).	210
Fig. 169. Central Model AD Water-control Valve & Release Cabinet.	213
Fig. 170. Control unit.	214
Fig. 171. Power unit.	215
Fig. 172. Electrical circuit for Central Model AD water-control valve. Relay contacts shown in energized position.	216
Fig. 173. Central Model AD water-control valve.	217
Fig. 174. Grinnell flooding valve Model B.	220
Fig. 175. Grinnell flooding valve trim.	221
Fig. 176. Grinnell flooding valve trim (air pilot line).	222
Fig. 177. Grinnell flooding valve trip (nitrogen pilot line).	223
Fig. 178. Grinnell Multimatic valve Model A-4, 4-inch (left) and 6-inch (right).	224
Fig. 179. Grinnell Multimatic valve Model A-4 with basic trim.	225
Fig. 180. Grinnell Multimatic valve Model A-4 with electric actuation trim and basic trim.	226
Fig. 181. Grinnell Electrospray preaction system.	227
Fig. 182. Grinnell Multimatic valve Model A-4 with dry pilot actuation trim (air) and basic trim.	228
Fig. 183. Grinnell Multimatic valve Model A-4 with dry pilot actuation trim (nitrogen) and basic trim.	229
Fig. 184. Grinnell Multimatic valve Model A-4 with alarm and test trim and basic trim.	230
Fig. 185. Grinnell dry pilot actuator, Model B-1.	232
Fig. 186. Grinnell Protomatic release Model F100.	233
Fig. 187. Grinnell Protomatic Release Model F100, installed with Multimatic valve	234
Fig. 189. Pneumatic Components of Protomatic Release.	235
Fig. 189. Protomatic Release, Mechanical Assemblies in operated positions.	236
Fig. 190. Explosion-proof low pressure alarm switch.	237
Fig. 192. Explosion-proof Fire Alarm Switch.	238
Fig. 192. Protomatic Detector.	239
Fig. 193. Auxiliary Enclosure for Mercury Checks for Protomatic Release.	240
Fig. 194. Supervisory Air Panel, Model F111, for Protomatic Release.	241
Fig. 195. Plant Air System for Protomatic Release	242
Fig. 196. Compressed Nitrogen System for Protomatic Release	242
Fig. 197. Housing Components and Trimmings for Protomatic Release.	243

2-10R Dry-Pipe, Deluge, Preaction Valves & Accessories

Fig. 198. Grinnell Multimatic Valve Model A-4.	244
Fig. 199. Hodgman Model A deluge valve.	246
Fig. 200. Model A pilot line actuator.	247
Fig. 201. Deluge valve installation, showing trimmings.	248
Fig. 202. Model 68 thermostatic release detector.	249
Fig. 203. Reliable Model B deluge valve.	250
Fig. 204. Reliable Model A dry pilot line actuator.	251
Fig. 205. Pilot line set-up (air).	252
Fig. 206. Pilot line set-up (nitrogen).	252
Fig. 207. Deluge valve with Model A actuator, basic trim.	253
Fig. 208. Deluge valve with Model A actuator, actuator trim.	255
Fig. 209. Supertrol deluge system.	256
Fig. 210. Supertrol pre-action system.	257
Fig. 211. Model A compressor panel.	258
Fig. 212. Model C air maintenance device.	258
Fig. 213. Rockwood Model K-2 (2-in.) water-control valve and release.	259
Fig. 214. Star Electromatic Model D water control valve, 6-inch (152-mm), with Star Model E Triple Action Release.	261
Fig. 215. Star Electromatic Model D water control valve, 3-inch (76-mm), with Star Model E Triple Action Release.	262
Fig. 216. Star Model D-1 power unit.	262
Fig. 217. Star Model D control unit.	263
Fig. 218. Star Electromatic Model D water control valve with preaction trim.	264
Fig. 219. Star Model F 3-inch deluge valve.	267
Fig. 220. Star Model F 6-inch deluge valve.	268
Fig. 221. Star Model AA pilot line actuator.	269
Fig. 222. Star Model F Hidromatic deluge valve.	270
Fig. 223. Star Model G-3-inch (7.6-cm) Hidromatic deluge valve.	272
Fig. 224. Star Model G 6-inch (15-cm)Hidromatic deluge valve.	273
Fig. 225. Star Model "AA-R" actuator.	274
Fig. 226. Component arrangement for dry pilot line - automatic maintenance using nitrogen as the pressurizing agent.	275
Fig. 227. Air pressure to be maintained in dry pilot based on system water pressure.	275
Fig. 228. Component arrangement for dry pilot line - automatic air maintenance - using owner's air supply as source.	276
Fig. 229. Electrical operation with provision for manual operation at deluge valve location.	276
Fig. 230. Wet pilot line operation - with valve for manual or system testing.	277
Fig. 231. Supervised preaction system.	278
Fig. 232. Wet pilot line operation manual emergency station for manual or system testing.	279
Fig. 233. Three-inch (7.6 cm) model.	279
Fig. 234. Six-inch (15 cm) model.	280
Fig. 235. Normal set condition (valve closed).	283
Fig. 236. Viking Firecycle system schematic.	284
Fig. 237. Operating condition (valve open).	285
Fig. 238. Cycle end condition (valve closed).	285
Fig. 239. Viking flow control valve. Model G-1 (upper) and Model G-2 (lower).	287
Fig. 240. Control cabinet, Model B-2.	288
Fig. 241. Valve trim box Model B-2. Note: Mount strainer horizontally, not vertically as shown.	289
Fig. 242. Detector, Model A.	289
Fig. 243. Mineral-insulated (MI) cable.	290
Fig. 244. MI connector.	290
Fig. 245. Detector location.	290
Fig. 246. Method of concealment of detector in ordinary- and extra-hazard occupancy areas.	291
Fig. 247. Method of concealment of detector in light-hazard areas.	291
Fig. 248. Viking Firecycle wiring diagram.	294
Fig. 249. Viking 6-in. Model D Automatic Water-control Valve with valve adapter plate for hydraulic release systems. Diaphragm bypass valve for pneumatic release systems shown above.	298
Fig. 250. (Upper) Viking deluge valve Model D2 and D3. (Lower) Viking deluge valve Model D4.	299

Dry-Pipe, Deluge, Preaction Valves & Accessories 2-10R

Fig. 251. Deluge system hydraulically operated with Type A thermostatic releases. Type A remote control, automatic sprinklers (minus deflectors), and emergency trip-valve release.	300
Fig. 252. Type A-4 thermostatic release.	301
Fig. 253. Types A, A-2, and A-3 thermostatic releases. Operating principle and other details same as Type A-4 thermostatic release. See Fig. 254.	301
Fig. 254. Model D2 diaphragm bypass valve.	302
Fig. 255. Deluge system - pneumatically operated with Type B thermostatic release and Type B remote manual control.	302
Fig. 256. Preaction sprinkler system - pneumatically operated with Type B thermostatic release and Type B remote control.	303
Fig. 257. Type B thermostatic release.	304
Fig. 258. Deluge system, hydraulically operated, with Model C thermostatic release and pressure-operated relief valve.	305
Fig. 259. Model C1 thermostatic release.	306
Fig. 260. Model C1 pressure-operated relief valve.	307
Fig. 261. Preaction sprinkler system - pneumatically operated with Model C thermostatic release.	308
Fig. 262. Deluge system, pneumatically operated, with Model C thermostatic release.	309
Fig. 263. Anti-water-columning device. Used to prevent water columning in hydraulic-release systems (shown with pressure in release system).	310
Fig. 264. Type A remote manual control. For use in hydraulic or pneumatic release systems.	310
Fig. 265. Model C air-pressure maintenance device. Used when air supply is from a plant air system. Shown with no pressure on outlet.	311
Fig. 266. Conversion of Model D and D2 valves with Model B and D2 bypass valves.	311
Fig. 267. Diaphragm relief valve. For pneumatic Type B release system.	312
Fig. 268. Release line accelerator. May be used to replace the diaphragm relief valve on pneumatic systems.	312
Fig. 269. Dehydrator. For use on pneumatic release systems exposed to freezing.	313
Fig. 270. Setting of Model C1 thermostatic release.	314

List of Tables

Table 1	12
Table 2	15
Table 3. System Air/Water Pressure.	23
Table 4	26
Table 5	27
Table 6	40
Table 7. Air pressure to be maintained with Model F and F-2 dry-pipe valves	40
Table 8	49
Table 9	54
Table 10. Required Air Pressure	62
Table 11	66
Table 12	70
Table 13	70
Table 14. System Air/Water Pressure	73
Table 15	74
Table 16	79
Table 17. System Air/Water Pressure.	90
Table 18. System Air/Water Pressure	94
Table 19	99
Table 20. System Air/Water Pressure.	101
Table 21. System Air/Water Pressure.	105
Table 22	107
Table 23.	108
Table 24.	112
Table 25	115
Table 26	116
Table 27. Air Pressure For Dry Pilot Line	254
Table 28. Maximum Distance of Pilot Line Sprinklers Above Deluge Valve.	277

2-10R Dry-Pipe, Deluge, Preaction Valves & Accessories

Table 29. Maximum Detector Spacing. Level Roof to 1 in. (25 mm) to 8 in. (203 mm) Roof Pitch. 292
Table 30. Maximum Detector Spacing. Peak Roof Pitch Greater than 1 in. (25 mm) to 8 in. (203 mm). . 292
Table 31. Maximum Detector Spacing. Shed Roof Pitch Greater than 1 in. (25 mm) to 8 in. (203 mm). . 293

1.0 SCOPE

This data sheet is a collection of manufacturers' information about previously produced dry-pipe, deluge, and preaction valves, and is provided for historical and reference purposes. Information on currently produced valves should be obtained from the manufacturers' websites. There are no plans to keep this data sheet up to date.

2.0 DRY-PIPE VALVES

2.1 Automatic (ASCOA) Model A

Dry-Pipe Valves — "Automatic" Model A

"AUTOMATIC" DRY-PIPE VALVE MODEL A-1925 TO 1927 4- AND 6-INCH

"Automatic" Sprinkler Co. of America, Youngstown, Ohio
Formerly International No. 5 (1921-1925). International No. 4 (1908-1921) made in 4- and 6-inch sizes was of similar design, the only difference being the shape of the body casting for the air clapper.

The "Automatic" Model A is a mechanical dry-pipe valve. Pressure exerted on the air clapper 13 (Fig. 1) acts through a series of levers to hold the water clapper 12 on its seat. When the air pressure is released, the weight 6 is tripped, freeing the support from the water clapper. Service pressure then forces the water clapper open and water enters the system.

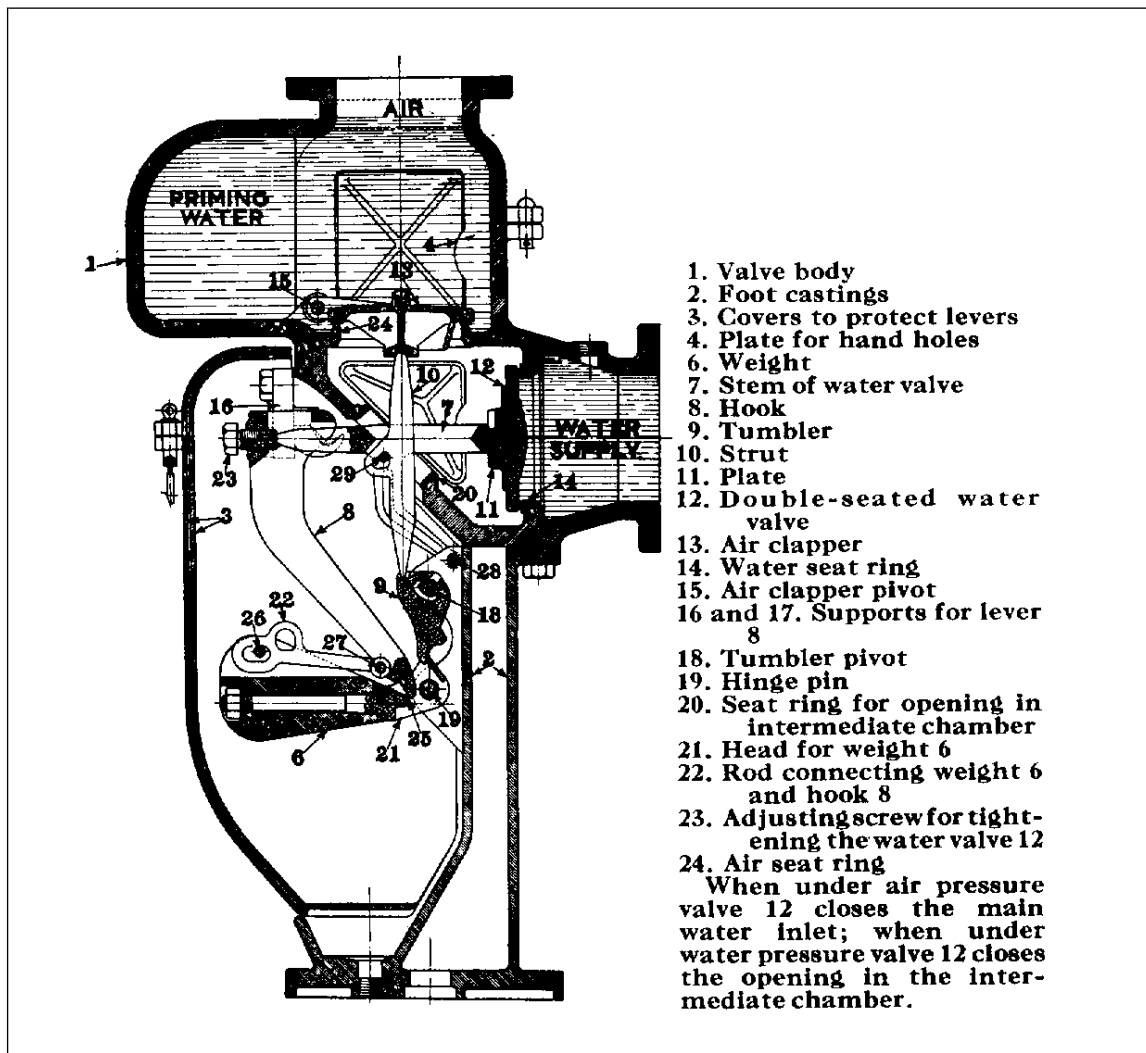

Fig.1. "Automatic" dry-pipe Model A

2-10R Dry-Pipe, Deluge, Preaction Valves & Accessories

To set the valve, drain the system and clean the valve seats and air and water clappers. Place the air clapper 13 on its seat and prime to level of valve D. (Fig. 2.) Pump air in the system to 35 lb. per sq. in.

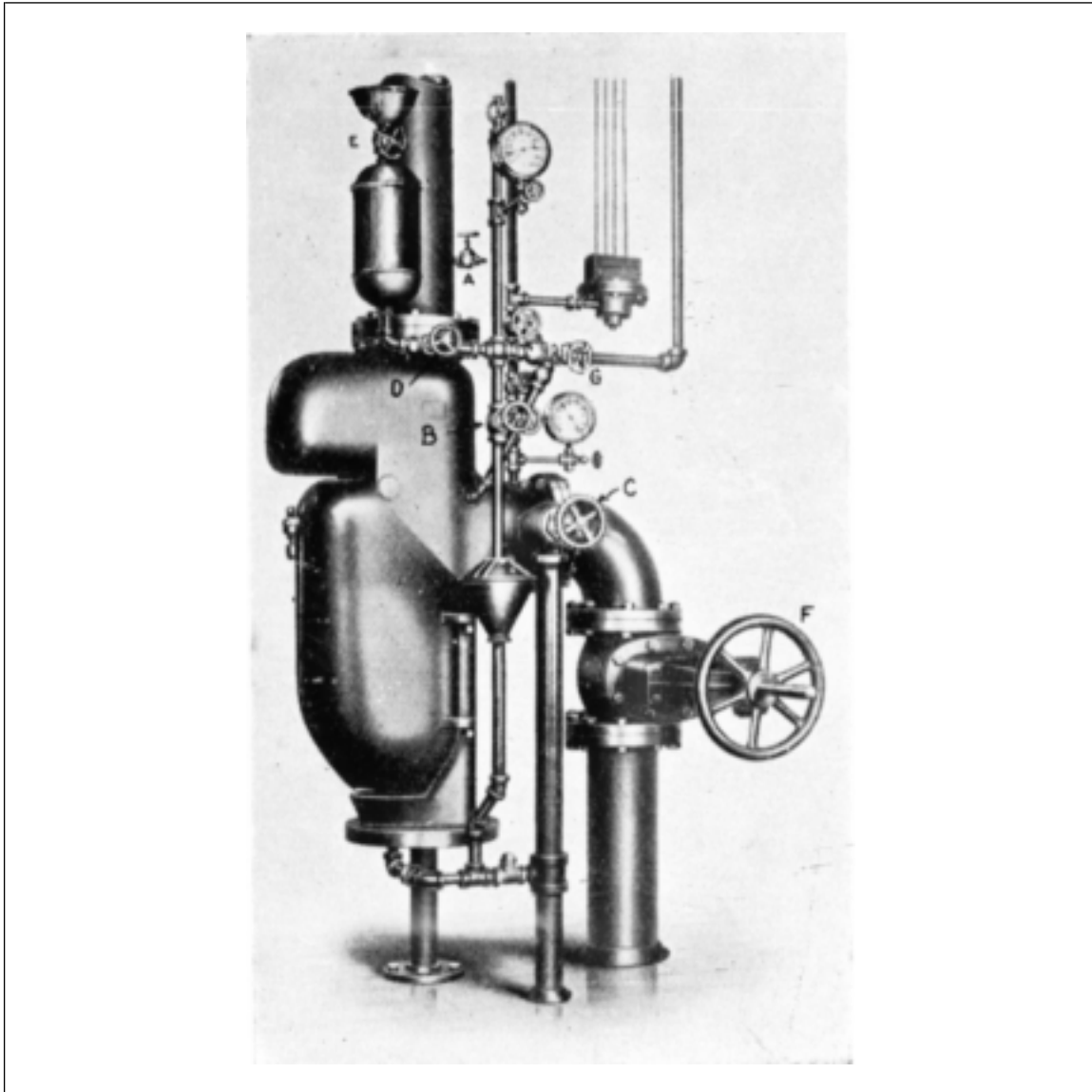

Fig. 2. 'Automatic' dry-pipe Model A

The tripping point of this valve is, within limits, not affected by the water pressure but is somewhat affected by the force applied to the adjusting screw 23. (Fig. 1.) This make of valve may be expected to trip at about 10 to 15 lb. per sq. in. air pressure.

Unscrew adjusting screw 23 flush with the inside surface of the bearing. Close water valve 12, then raise weight 6 and bring hook 8 and tumbler 9 to the position shown in Fig. 1. With weight 6 still supported, place the upper end of strut 10 against the under side of air clapper 13, and the lower end in groove of 9, after which tighten adjusting screw 23 slightly. Open main gate valve F (Fig. 2) slightly to let water pressure against water valve 12. (Fig. 1.) Tighten adjusting screw 23 until the leakage past water valve 12 ceases. Where a pump is used as an auxiliary supply or where high service pressures are likely to be turned into the system, valve 12 should be made tight against the maximum pressure. Open wide main gate valve F. (Fig. 2.) Put priming apparatus for air clapper in service. Test the water supply by opening drain valve C.

2.2 Automatic (ASCOA) Models B, B-2, and 39

“Automatic” Dry-Pipe Valve

MODEL B, 6 IN. (152 mm) 1927-1931 MODEL B-2, 6 IN. (152 mm) 1931-1939

“Automatic” Sprinkler Corp. of America, Div. American Lafrance, Sub. A-T-O, Cleveland, Ohio

DESCRIPTION

Models B and B-2 are similarly constructed differential dry-pipe valves. The original Model B clappers were replaced with more reliable Model B-2 clappers (Fig. 4). If a Model B valve with the original clapper (Fig. 3) is found, the clapper should be replaced with a Model B-2 clapper. Air pressure acting on air clapper 1 exerts a force through water clapper arm 2, holding water clapper 3 closed. In set position air clapper 1 rests on air seat 4, and water clapper 3 rests on water seat 5.

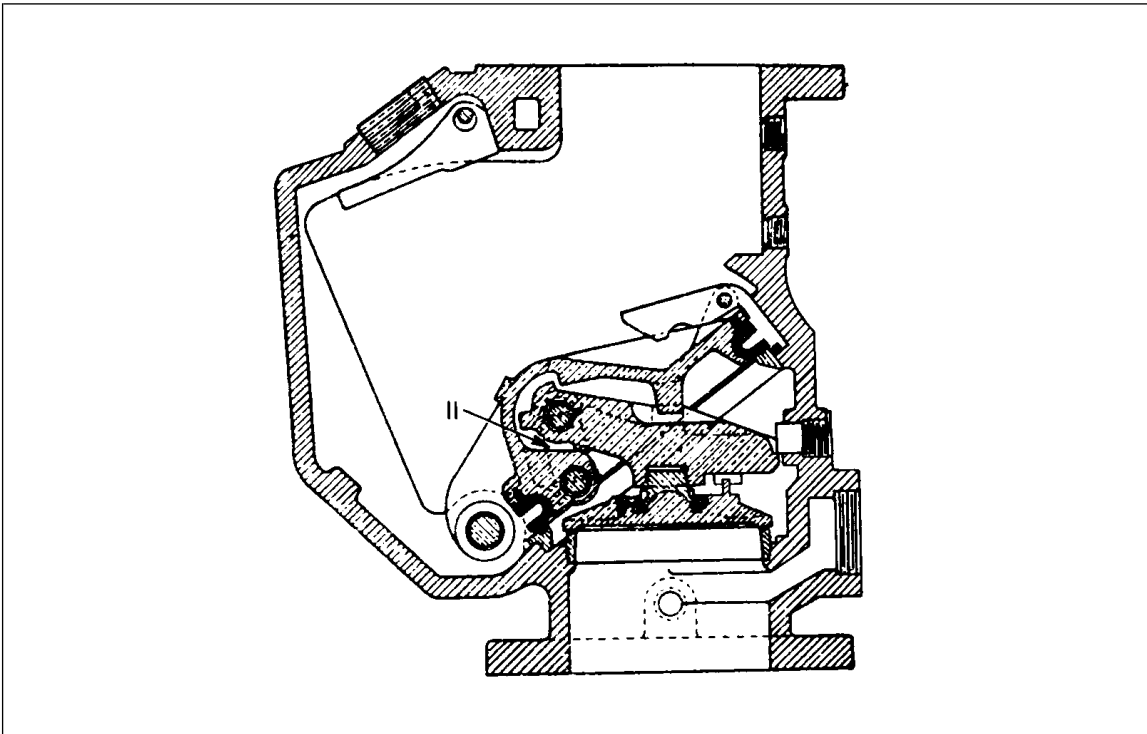

Fig. 3. “Automatic” Model B dry-pipe valve with original clapper.

When system air pressure is reduced sufficiently, water pressure will force water clapper 3 to tilt slightly, allowing water to enter the intermediate chamber destroying the differential and causing the air and water clappers to open. These clappers are held in the open position by gravity latch 8.

SETTING

1. Close the main control valve supplying water to the system.
2. Open main drain valve B (Fig. 5) and all drawoff valves and vents at low points throughout the system; close them when water ceases to flow.
3. Remove cover of the dry valve and lift gravity latch 8, placing anticolumn latch 7 on top notch 10.
4. Carefully clean air clapper 1, water clapper 3, air seat 4, water seat 5, and rubber facing 6.
5. Lift anticolumn latch 7 and place air clapper 1 with water clapper 3 on their respective seats. The pressure of air clapper 1 will force water clapper arm 2 under the Monel plug 9.
6. Replace cover on the dry-pipe valve.

2-10R Dry-Pipe, Deluge, Preaction Valves & Accessories

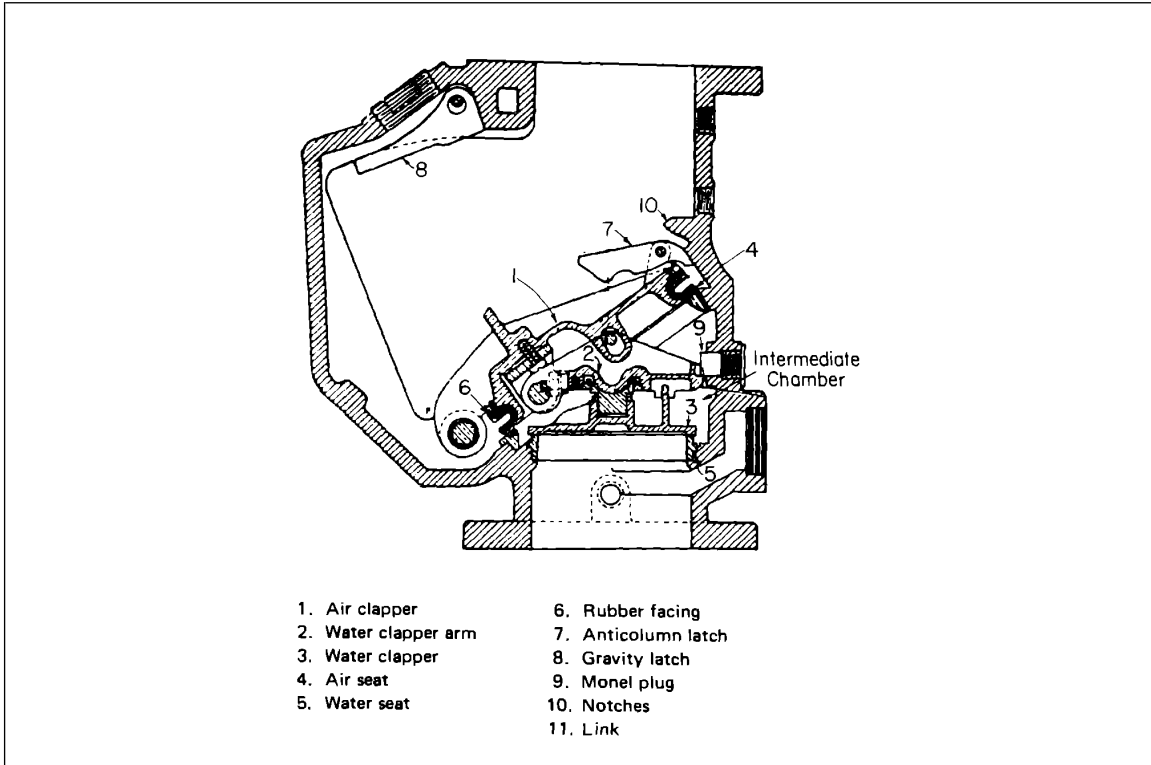

Fig. 4. "Automatic" Model B-2 dry-pipe valve.

7. Open upper priming valve C (Fig. 5) and lower priming valve D. Make sure test valve G is closed. Add water through priming cup F until water remains in it. Open test valve G; close it when water ceases to flow. Close lower priming valve D, and fill priming chamber E with water. Close upper priming valve D when finished.

8. Pump air into the system.

Table 1

Highest Service Water Pressure or Fire Pump Pressure			Air Pressure					
			Not Less Than			Not More Than		
psi	(kPa)	(bars)	psi	(kPa)	(bars)	psi	(kPa)	(bars)
50	(345)	(3.45)	15	(103)	(1.03)	25	(172)	(1.72)
75	(517)	(5.17)	20	(138)	(1.38)	30	(207)	(2.07)
100	(689)	(6.89)	25	(172)	(1.72)	35	(241)	(2.41)
125	(862)	(8.62)	30	(207)	(2.07)	45	(310)	(3.10)
150	(1034)	(10.3)	35	(241)	(2.41)	50	(345)	(3.45)

9. Open wide the main control valve.

10. Make sure no leakage occurs at the drip valve.

11. Test the water supply by opening main drain valve B.

NOTE: The trip points of this valve can be changed by adjusting the retaining ring on the stud which attaches the water clapper to the air clapper. Sufficient increase in distance between the water clapper and the stress lever could cause sluggish operation or perhaps failure. This adjustment compensates for wear or slight damage to the water-and air-clapper assembly. If adjustment is needed, it should be done by the manufacturer's representative.

When inquiry regarding maintenance of the valve indicates adjustments were made, the valve should be trip tested.

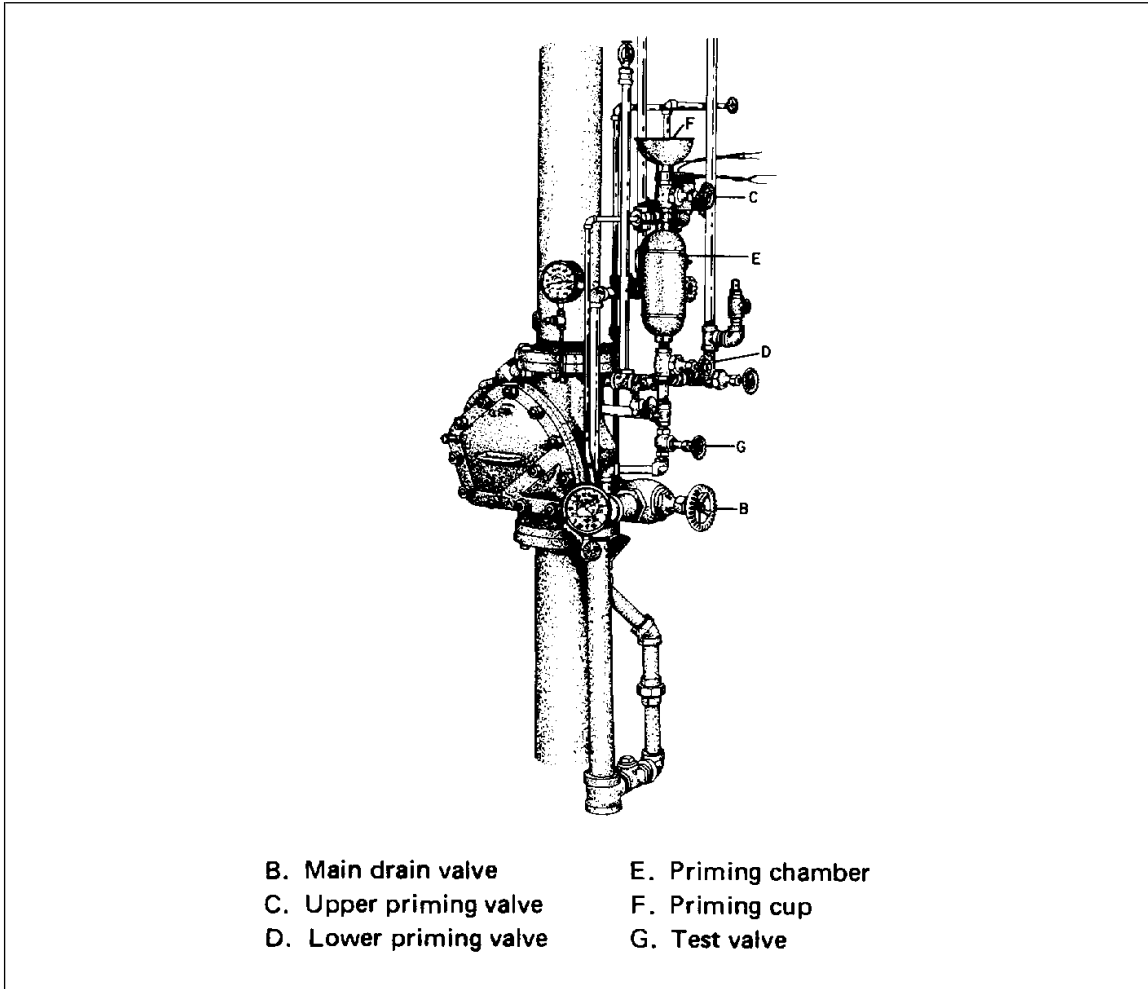

Fig. 5. "Automatic" Model B-2 dry-pipe valve trim.

"AUTOMATIC" DRY-PIPE VALVE MODEL 39 6 IN. (152 mm) 1939 TO DATE
"Automatic" Sprinkler Corp. of America, Div. American Lafrance, Sub. A-T-O, Cleveland, Ohio

DESCRIPTION

"Automatic" Model 39 is a differential dry valve with air and water clappers combined in one circular bronze disc (Fig. 6). In set position clapper 1 rests on air seat 3 and water seat 4.

When system air pressure is reduced sufficiently, water pressure will force clapper 1 to rise slightly. Water enters the intermediate chamber destroying the dry-valve differential and causing clapper 1 to open. Clapper 1 is then out of the waterway or held open by latch 2 engaging the notches 6 in the valve body.

SETTING

1. Close the main control valve supplying water to the system.
2. Open main drain valve B (Fig. 7) and all drawoff valves and vent at low points throughout the system; close them when water ceases to flow.
3. Remove cover of valve. Lift and latch clapper 1 open.
4. Carefully clean air seat 3, water seat 4, and rubber facing 5.
5. Raise latch 2 and place clapper 1 on its respective seat.
6. Replace and tighten cover.

2-10R Dry-Pipe, Deluge, Preaction Valves & Accessories

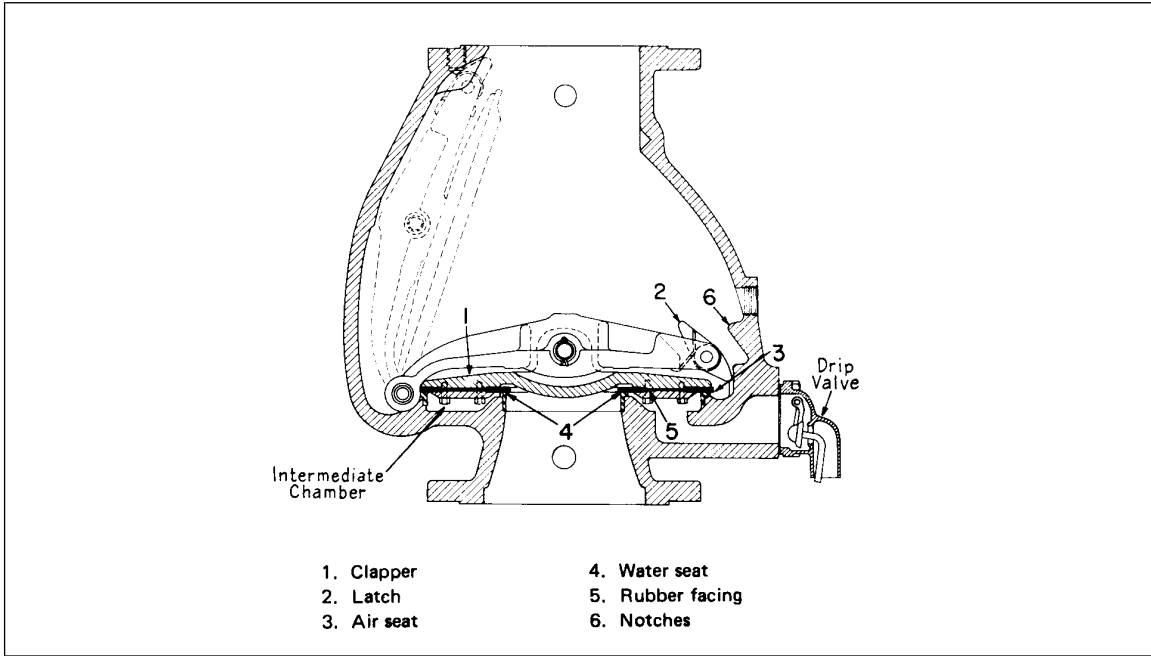

Fig. 6. "Automatic" Model 39 dry-pipe valve, internal view.

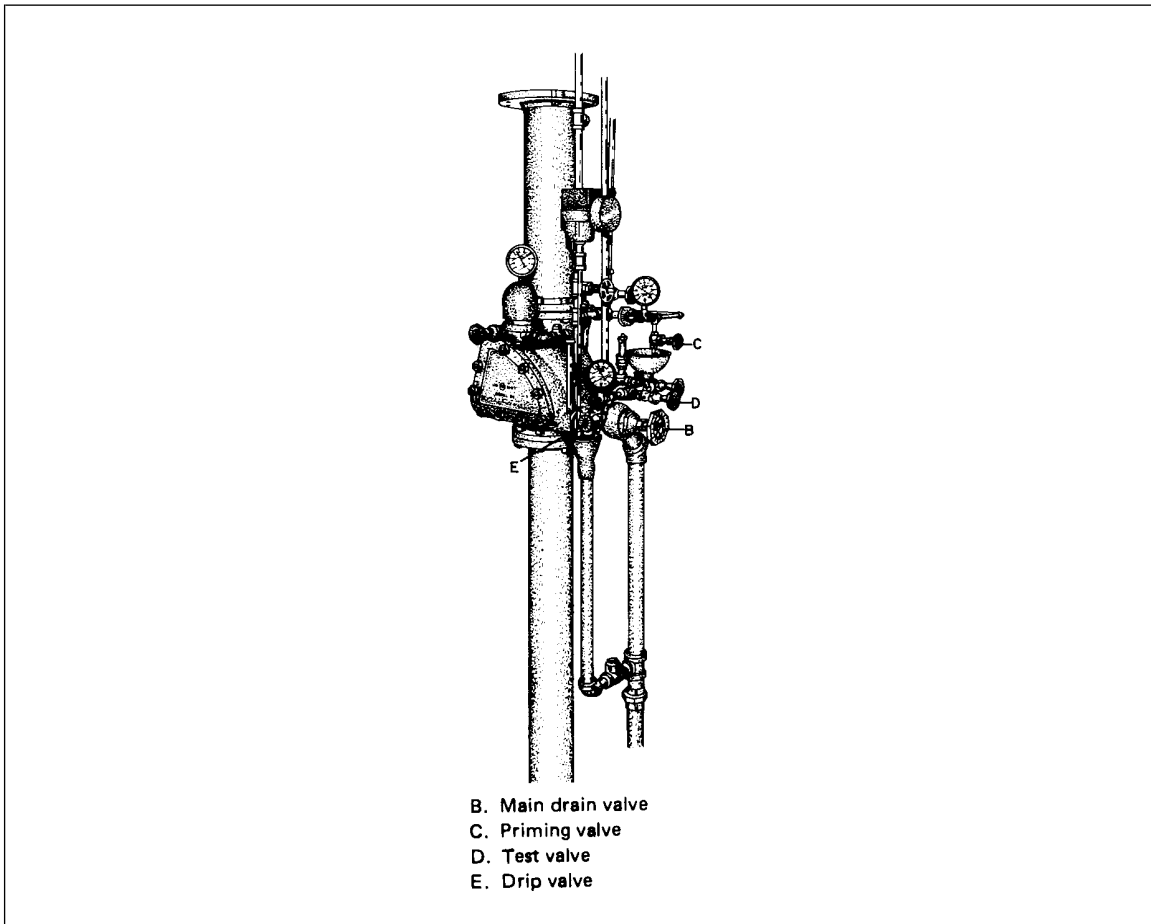

Fig. 7. "Automatic" Model 39 dry-pipe valve trim.

Dry-Pipe, Deluge, Preaction Valves & Accessories 2-10R

7. Open priming valve C allowing priming water to enter the dry-pipe valve. When water reaches level of test valve D, close priming valve C.

8. Open air supply valve and pump air into the system.

Table 2

Highest Service Water Pressure or Fire Pump Pressure			Air Pressure					
			Not Less Than			Not More Than		
psi	(kPa)	(bars)	psi	(kPa)	(bars)	psi	(kPa)	(bars)
50	(345)	(3.45)	15	(103)	(1.03)	25	(172)	(1.72)
75	(517)	(5.17)	20	(138)	(1.38)	30	(207)	(2.07)
100	(689)	(6.89)	25	(172)	(1.72)	35	(241)	(2.41)
125	(862)	(8.62)	30	(207)	(2.07)	45	(310)	(3.10)
150	(1034)	(10.34)	35	(241)	(2.41)	50	(345)	(3.45)

9. **Open wide the main control valve.**

10. Make sure no leakage occurs at drip valve E.

11. Test the water supply by opening main drain valve B.

2-10R Dry-Pipe, Deluge, Preaction Valves & Accessories

2.3 Central Model AD

Central Dry-Pipe Valve Model AD 6-inch

1947

Central Automatic Sprinkler Co., Inc., Lansdale, Pa.

2.3.1 Central Dry-Pipe Valve Model AD 6-inch

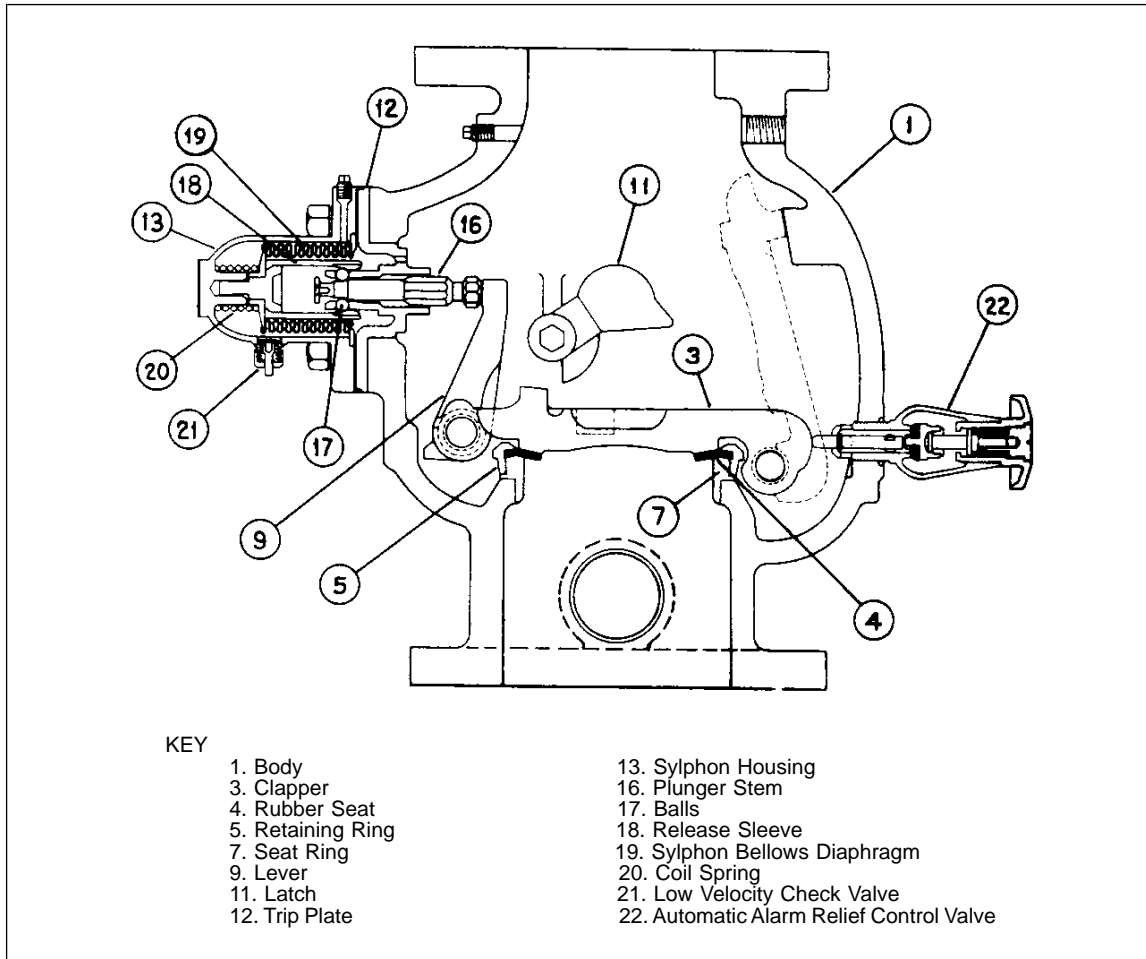

Fig. 8. Sectional View of Central "AD" Dry-Pipe Valve in Normal Closed Position

DESCRIPTION

Dry-Pipe Valve

The Central Model AD dry-pipe valve (Fig. 8) is a low pressure, mechanical type having a single swing clapper. There is no intermediate chamber. Approximately 23 psi. air pressure is maintained in the sprinkler system regardless of water pressure. At ordinary water pressures the trip point is between 7 and 8.4 psi. A float drain attachment is required by Factory Mutual approval to drain off automatically accumulated condensation of water leakage past the clapper. (Fig. 10)

The clapper (3) is held on a flat rubber seat (4) by lever (9) connecting to a mechanical release operated by reduction of air pressure in the dry-pipe system. Water pressure acts on the under side of the rubber seat forcing it against the clapper to provide a seal. There is no latch to retain the clapper in wide open position when tripped, but a latch is provided on the cover to prevent the clapper returning to its seat and to permit drainage of the piping.

Mechanical Release

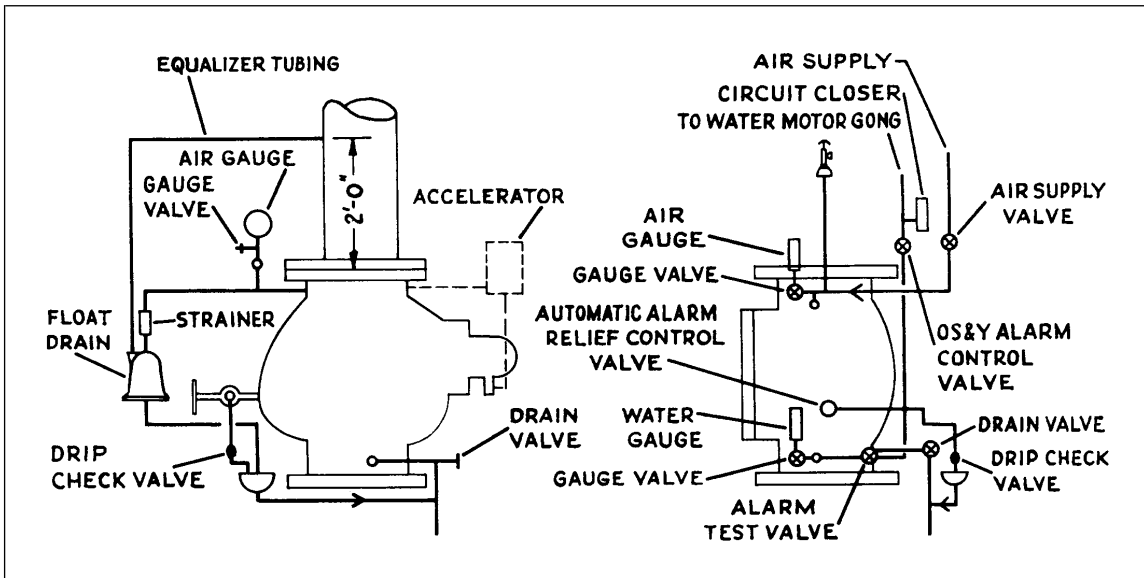

Fig. 9. Trimmings for 6-Inch Central "AD" Dry-Pipe Valve

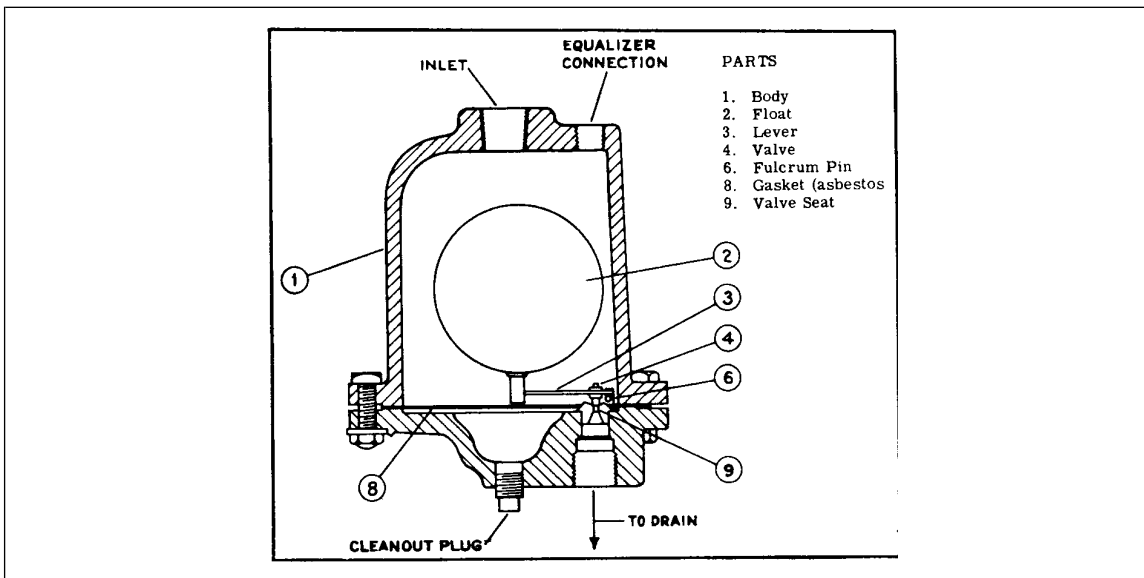

Fig. 10. Automatic Float Drain for Use with 6-Inch Central "AD" Dry-Pipe Valve

The mechanical release in the Syphon housing (13) consists of a cylindrical tapered release sleeve (18), mounted within a Syphon bellows (19), four balls in a ball retainer (17) to form a stop for a shoulder on the plunger stem (16) and hold the stem in the set position, and a coil spring (20) located between the end of the bellows and the release housing.

Automatic Alarm Relief Control Valve

The automatic alarm relief control valve (22) admits water to the alarm piping when the clapper is raised. It also releases air pressure in excess of 23 psi. automatically and provides means for a manual test to determine the presence of water above the clapper. When making water column tests at valves equipped with an accelerator, automatic alarm relief control valve (22) should be cracked open slowly to prevent accidental tripping of the dry-pipe valve.

OPERATION

2-10R Dry-Pipe, Deluge, Preaction Valves & Accessories

When the dry-pipe valve is in the set position the plunger stem (16) bears against and holds lever (9) in an upright position to bear on the toe of the clapper (3) holding it closed. System air pressure passing to the release sleeve (18) through a small port and clearance between the plunger stem (16) and trip plate (12), moves the release sleeve (18) away from the trip plate, stretches the bellows (19), and compresses the coil spring (20). Movement of the release sleeve forces the balls in the retaining ring (17) inward against the shoulder of the plunger stem (16), holding lever (9) in the set position.

When the air pressure in the release sleeve (18) is reduced to the trip point (8.4 psi.) the compressed coil spring (20) causes the bellows (19) to contract and the tapered release sleeve (18) to move toward the trip plate (12) allowing the balls (17) to move outward from plunger stem (16), releasing the force holding lever (9) in place. Water pressure on clapper (3) then causes the valve to trip.

A low velocity check valve (21), which vents the release housing to the atmosphere, closes automatically with pressure above 15 to 18 psi. This valve is comparable to the ball check connected to the neutral chamber of a differential type dry valve.

The general method of operation of the float drain is apparent from Fig. 10. Air entrapped in the float chamber is vented through the equalizer line to the sprinkler system.

The spring loaded automatic alarm relief control valve (22) opens as the clapper lifts admitting water to alarm piping to operate hydraulic and electric alarms.

SETTING

To set the dry-pipe valve, close the main control valve, drain the system, leave drain valve open, remove the cover, and thoroughly clean the rubber seat ring and clapper. Place clapper (3) on its seat and return lever (9) to the vertical position to bear on the toe of the clapper. Move the plunger stem (16) to make contact with the internal lever (9). This valve will not set unless the plunger is "pulled out" by hand. The cover is then bolted in place and air pressure of 23 psi. is applied above the clapper. The 2-in. drain valve must be left open while admitting air to allow any water leakage by the main control valve to flow off without building up pressure under the clapper before maximum system air pressure is established. The mechanical release resets automatically as air pressure builds up in the system. Before opening the control valve, the low velocity check valve (21) on the Syphon housing of the mechanical release should be raised manually to drain and assure venting the Syphon housing to atmosphere. Also, the alarm relief control valve (22) should be checked to be sure that there is no leakage past the seat. In the event of air leakage at this point, the disc and seat of the valve (22) must be cleaned.

MAINTENANCE

Following the annual trip test, clapper (3), lever (9), rubber seat (4), and plunger stem (16) should be examined and cleaned. Make sure that all parts, especially the plunger stem (16) in trip plate (12), move freely when operated manually.

2.3.2 CENTRAL MODEL C DRY-PIPE VALVE

CENTRAL MODEL C DRY-PIPE VALVE

6-inch - 1955

4-inch - 1957

3-inch - 1959

The Central Model C dry-pipe valve is a differential type having a single rubber-faced clapper covering both the air and water seats. Upon operation the clapper swings clear of the waterway and is held open by the engagement of latch (17) with the anticolumning, intermediate, or wide-open stop.

The three sizes of valves are similar in design. The 6-inch has an average differential of 5.6 to 1, the 4-inch 5.8 to 1, and the 3-inch 6.6 to 1.

To set, close the main control valve and drain the system, leaving the drain valve open. Remove the cover and thoroughly clean the air- and water-seat diaphragm (16), water-seat ring (5), and air-seat ring (6). Unlatch clapper (7) and place it on the seat rings. Bolt the cover in place. Admit priming water through the priming chamber to the proper level and admit air to the proper pressure.

Open the main control valve until water starts to flow from the main drain. Close the drain valve slowly and make sure, by pushing on its plunger, that the drip valve is off its seat and free to move. Be sure that no leakage appears at the drip valve. Open the main control valve to the wide-open position.

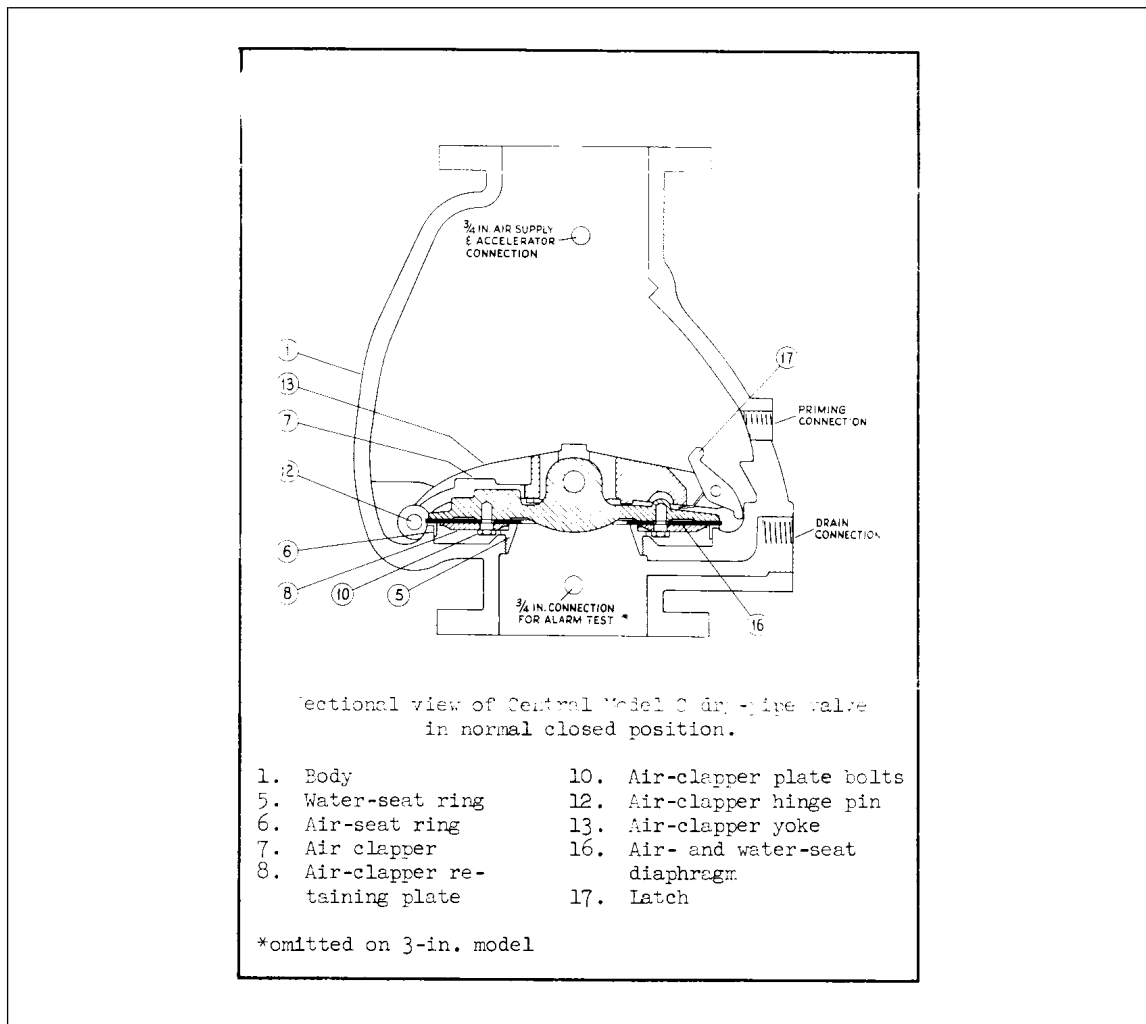

Fig. 11. Sectional view of Central Model C Dry-Pipe Valve in normal closed position.

Make a drain test through the drain valve. After determining that the main control valve is wide open, seal.

2.4 Chemetron "Star" Models F and G

Chemetron "Star" Dry-Pipe Valves

- 3 in. (76 mm), 1963 TO 1971
- MODEL F* 6 in. (52 mm), 1966 TO 1971
- 4 in. (102 mm), 1967 TO 1971
- 3 in. (76 mm), 1963 TO 1971
- MODEL F* 6 in. (52 mm), 1966 TO 1971
- 4 in. (102 mm), 1967 TO 1971
- 3 in. (76 mm), 1971
- MODEL G** 4 in. (102 mm), 1971
- 6 in. (152 mm), 1971

Chemetron Corp., Fire Systems Div., Star Sprinkler Products,
Cornwells Heights, PA.

*The Model F valves installed by Firematic Sprinkler Devices, Inc. have a cover plate marked FIREMATIC. The Model F valves installed by Superior Automatic Sprinkler Co., Inc. have a cover plate marked SUPERIOR.

**The Model G valve is similar to the Model F valve. It was designed to ease manufacturing procedures. The Model G valves installed by the Fire Protection Co. and the Automatic Sprinkler Co., Inc. have cover plates respectively marked with the F.P.C. and Automatic names.

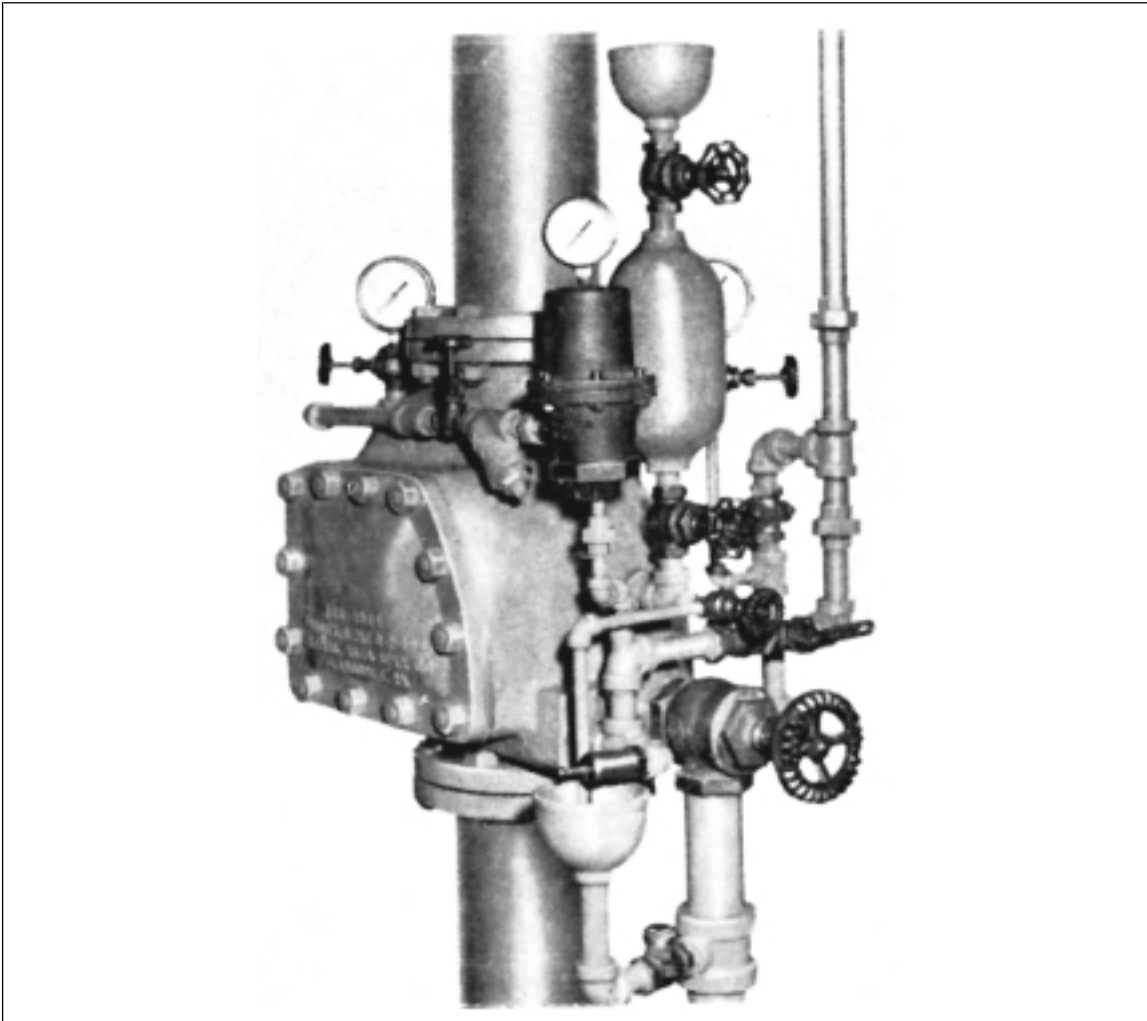

Fig. 12. Central Model C dry-pipe valve with Model AD accelerator and connections.

Chemetron “Star” Dry-Pipe Valves

Data Sheet 2-87 has been revised to reflect that Chemetron Corp. manufactures the Star dry-pipe valve. Valves are manufactured at their Monee, Illinois facility.

Reference is made to the Fire Protection Co. (F.P.C.) and the Automatic Sprinkler Co., Inc., which are mainly sprinkler system installation companies. Chemetron “Star” Model G dry-pipe valves bearing cover plates with the F.P.C. or Automatic names are listed in the current Approval Guide.

DESCRIPTION

Basically, the Model F dry-pipe valve retains all the design features of the 3-in. (76-mm) Model D (Data Sheet 2-29) with one major exception: the tripping mechanism or differential attachment, which is bolted to one side of the valve body, has been redesigned to eliminate manufacturing difficulties (Fig. 13).

Both the 3- and 6-in. (76-mm and 152-mm) valves have similar clapper assemblies, having the air seat disc held in place by a threaded cap with a cotter pin. The 4-in. (102-mm) valve air seat disc is held in place by a bolt, threaded through the top half of the clapper. The clapper latch 6DF-6 on the 3- and 4-in. (76-mm and 102-mm) valves pivots on the latch hinge pin 6DF-3A. The clapper latch on the 6-in. (152-mm) valve is attached to a stud which is screwed through the side of the valve body.

In this valve, practically all of the difference between the water and air pressure is restrained by the multiplying action of a retaining lever 6DF-7. In the closed position, a double-seated swing clapper 6DF-4 is held on



6DF-2	Valve cover	6DF-5	Seat ring
6DF-2A	Cover studs	6DF-5A	Neutral chamber nipple
6DF-2B	Cover nuts	6DF-5B	Packing gland
6DF-2C	Cover gasket	6DF-5C	Gland packing
6DF-2D	Cover dowel	6DF-5D	Gland packing
6DF-2E	Cover jack screw	6DF-6	Clapper latch
6DF-3	Clapper arm	6DF-6A	Clapper latch stud
6DF-3A	Hinge pin	6DF-6B	Clapper latch lock nut
6DF-3B	Hinge pin bushing	6DF-6C	Clapper latch string
6DF-3C	Hinge pin plug	6DF-7	Retaining lever
6DF-3D	Clapper arm nose plate	6DF-8	Water seat disc
6DF-3E	Plate retaining screw	6DF-8A	Water seat disc ring
6DF-4	Water clapper	6DF-9	Air seat disc
6DF-4A	Clapper retaining nut		

DIFFERENTIAL ATTACHMENT PARTS

6DAF-1	Differential valve housing	6DAF-3	Differential valve plunger
6DAF-1A	Housing gasket	6DAF-3A	Plunger nose
6DAF-1B	Housing studs	6DAF-3B	Plunger nose pin
6DAF-1C	Housing nuts	6DAF-3C	O-ring seal
6DAF-2	Differential valve plate	6DAF-4	Differential valve disc
6DAF-2B	Dowel tube	6DAF-4A	Inner disc retainer
6DAF-2C	Plate gasket	6DAF-4B	Outer disc retainer
6DAF-2D	Location pin	6DAF-4C	Assembly lock nut
		6DAF-5	Differential valve spring

Fig. 13. Star Model F dry-pipe valve.

2-10R Dry-Pipe, Deluge, Preaction Valves & Accessories

its seat by the retaining lever 6DF-7, the other end of which rests against the plunger 6DAF-3A extending into the valve body at right angles to the axis of the valve. The plunger is held against the retaining lever by a differential valve disc 6DAF-4 operated by the air pressure in the sprinkler system.

The differential valve which is the primary tripping device consists of a housing 6DF-1 open to system air pressure, which encloses a spring-loaded rubber-faced disc 6DAF-4, covering an annular groove in the seat. The groove is vented to atmosphere.

Latch points, to prevent reseating of the valve after it has opened, are provided by projections on the hinge pin guide.

OPERATION

When the valve is set, the force of the water pressure on the clapper 6DF-4 is transmitted through the retaining lever 6DF-7, to the plunger 6DAF-3. This force is resisted by the spring 6DAF-5 and the system air pressure acting on the area of the groove seat of the differential valve. The spring force is not sufficient of itself to overcome the thrust of the plunger. When sprinkler opens and the air pressure falls, the point is reached where the disc 6DAF-4 of the differential valve is forced off its seat. This action permits the plunger to move back and the retaining lever to rotate, freeing the main clapper. Water pressure then throws the clapper open. Reseating is prevented by the engagement of the latch 6DF-6 with the projections on the hinge pin guide.

RESETTING

Refer to Fig. 13.

1. Close valve controlling water supply to system.
2. Open main drain valve and all draw-off valves and vents throughout the system, closing each when water has ceased to flow.
3. Remove cover plate, using jack screws if necessary. With a clean cloth, carefully wipe clean the rubber air seat disc 6DF-9, water seat disc 6DF-8, water clapper 6DF-4, and seat ring 6DF-5.
4. Remove differential valve housing 6DAF-1. Clean out any sludge. Wipe clean the valve-disc 6DAF-4 and the seating surface to which it closes on the valve plate 6DAF-2. Carefully replace the valve spring 6DAF-5 and valve housing 6DAF-1, and bolt up tight.
5. Carefully lower the clapper assembly to the closed position by releasing the clapper latch 6DF-6. Make certain that the "bridging strut" between the two legs of the retaining lever 6DF-7 is properly engaged over the clapper arm 6DF-3 and at the plunger nose 6DAF-3A, and that the plunger 6DAF-3 moves freely to contact with the retaining lever 6DF-7.
6. Replace valve cover plate and bolt up tight.
7. Refer to Fig. 14. Remove the plug B and the open valve C and D. Prime the valve by running water into the priming chamber D-25 until water flows from Test valve D. Then replace plug B and close valve C. Do not close test valve D until water has ceased to flow. Note: the priming water level should never be above the test valve D.

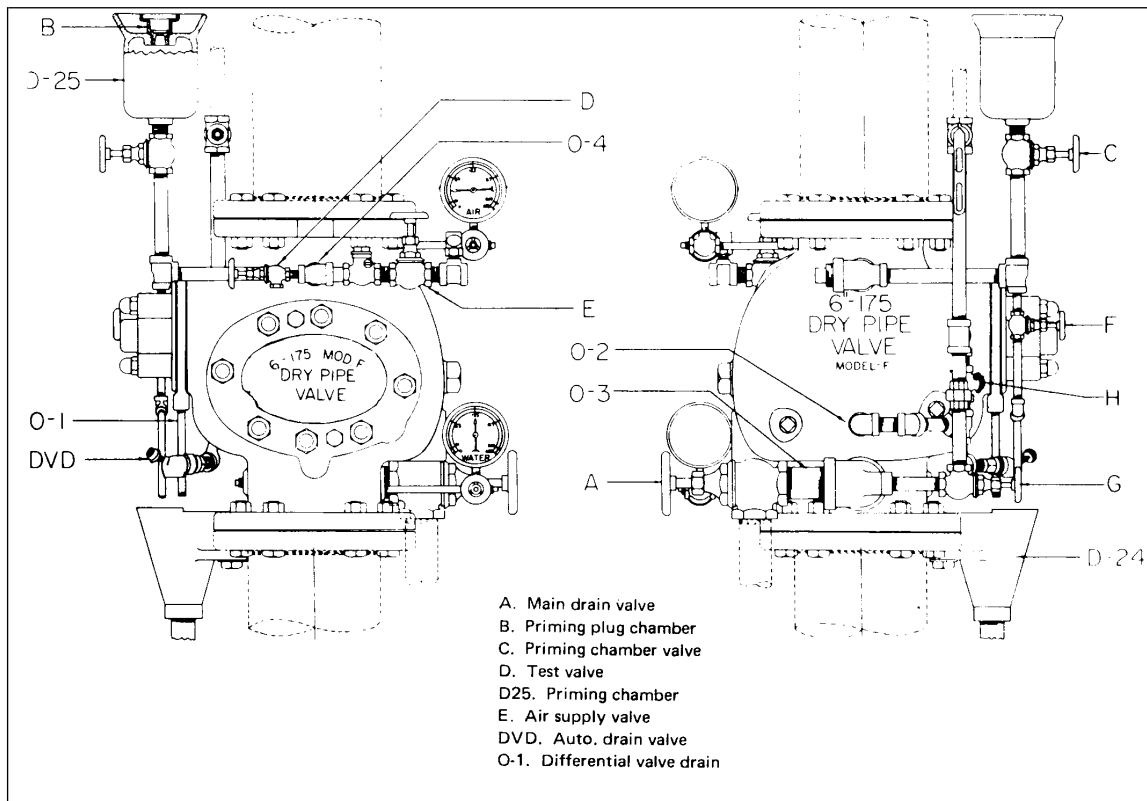

Fig. 14. Trim on Star Model F dry-pipe valve.

8. Open valve E to admit a few pounds of air pressure into the system. Then open system draw-off valves and vents individually to force all water from low points in the system. As this step is completed at each location, make certain the valve or vent is tightly closed before leaving.

9. Admit sufficient air pressure to hold the dry-pipe valve closed against maximum water pressure as indicated in Table 3.

Table 3. System Air/Water Pressure.

Maximum Water Pressure			Air Pressure					
			Not Less Than			Not More Than		
psi	(kPa)	(bars)	psi	(kPa)	(bars)	psi	(kPa)	(bars)
50	(345)	(3.5)	15	(103)	(1.0)	25	(172)	(1.7)
75	(517)	(5.2)	20	(138)	(1.4)	30	(207)	(2.1)
100	(689)	(6.9)	25	(172)	(1.7)	35	(241)	(2.4)
125	(862)	(8.6)	30	(207)	(2.1)	45	(310)	(3.1)
150	(1034)	(10.3)	35	(241)	(2.4)	50	(345)	(3.5)
175	(1207)	(12.3)	40	(276)	(2.8)	50	(345)	(3.5)

10. When the required air pressure has been established in the system, tightly close valve E. Then inspect the automatic drain valve DVD and the differential drain valve O-1. Check the automatic drain valve DVD by pushing inwardly on the manual drain valve pin cap DVD-5A to insure ball is free from ball seat.

11. Open slightly the water control valve and again check valves O-1 and DVD. If no leakage is observed, air and water seats are tight. Open water control wide and lock valve. Dry-pipe valve is now reset and the sprinkler system is restored.

2.5 Crowder Model A

Crowder Dry-Pipe Valve

MODEL A 6 INCH 1924 TO 1951

Crowder Brothers, St. Louis, Mo.

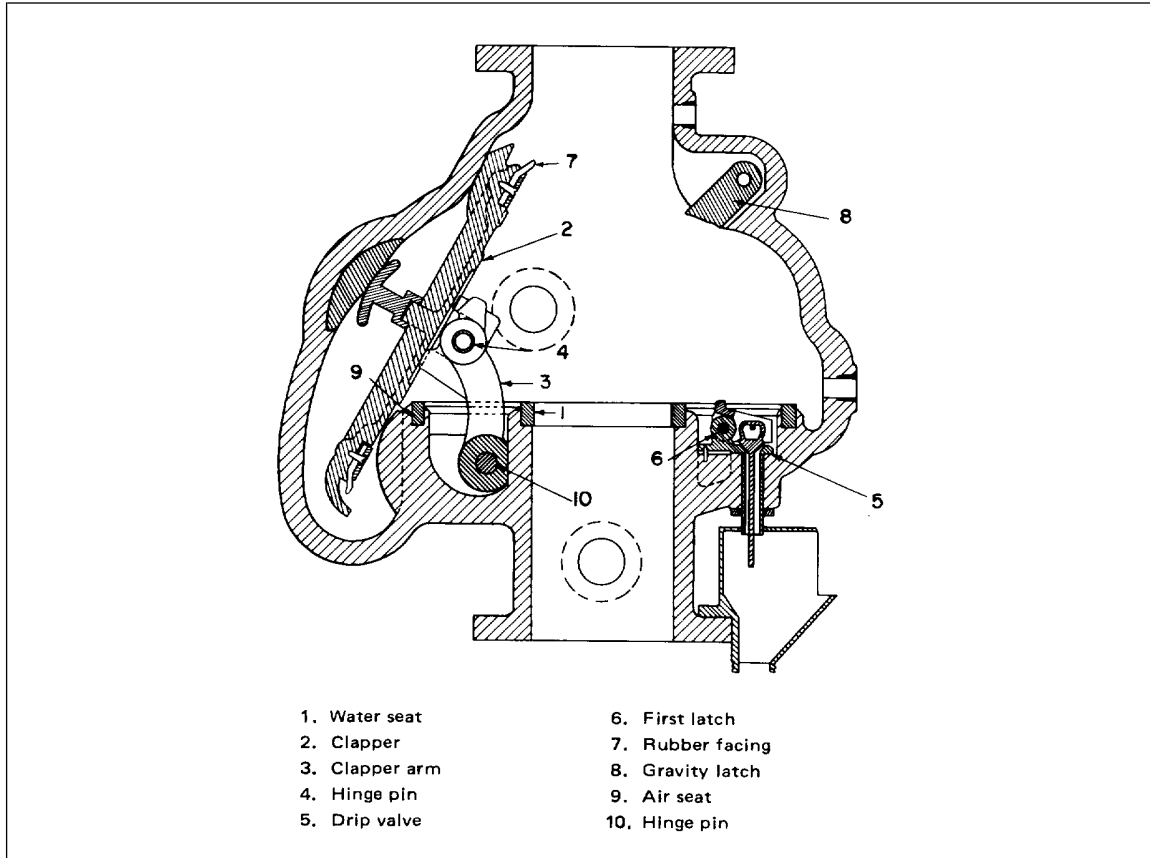

Fig. 15. Crowder Model A dry-pipe valve.

DESCRIPTION

The Crowder Model A dry-pipe valve (Fig. 15) is a differential valve. The air and water clappers are combined in one circular bronze plate. The clapper (2, Fig. 15) is hinged to clapper arm (3, Fig. 15) by a hinge pin (4, Fig. 1) and pivots about another hinge pin (10, Fig. 15).

OPERATION

When the dry-pipe valve is in set position, clapper 2 rests on the air seat (9, Fig. 15) and water seat (1, Fig. 15). System air pressure on clapper 2 resists water pressure at a ratio of 1 psi air pressure to 6 or 7 psi water pressure.

When system air pressure is reduced sufficiently, water pressure will force clapper 2 open. The clapper 2 is then out of the waterway or held open by the gravity latch (8, Fig. 15).

SETTING

1. Close main control valve A supplying water to the system.
2. Open main drain valve B and all draw-off valves and vents at low points throughout the system, closing them when water ceases to flow.

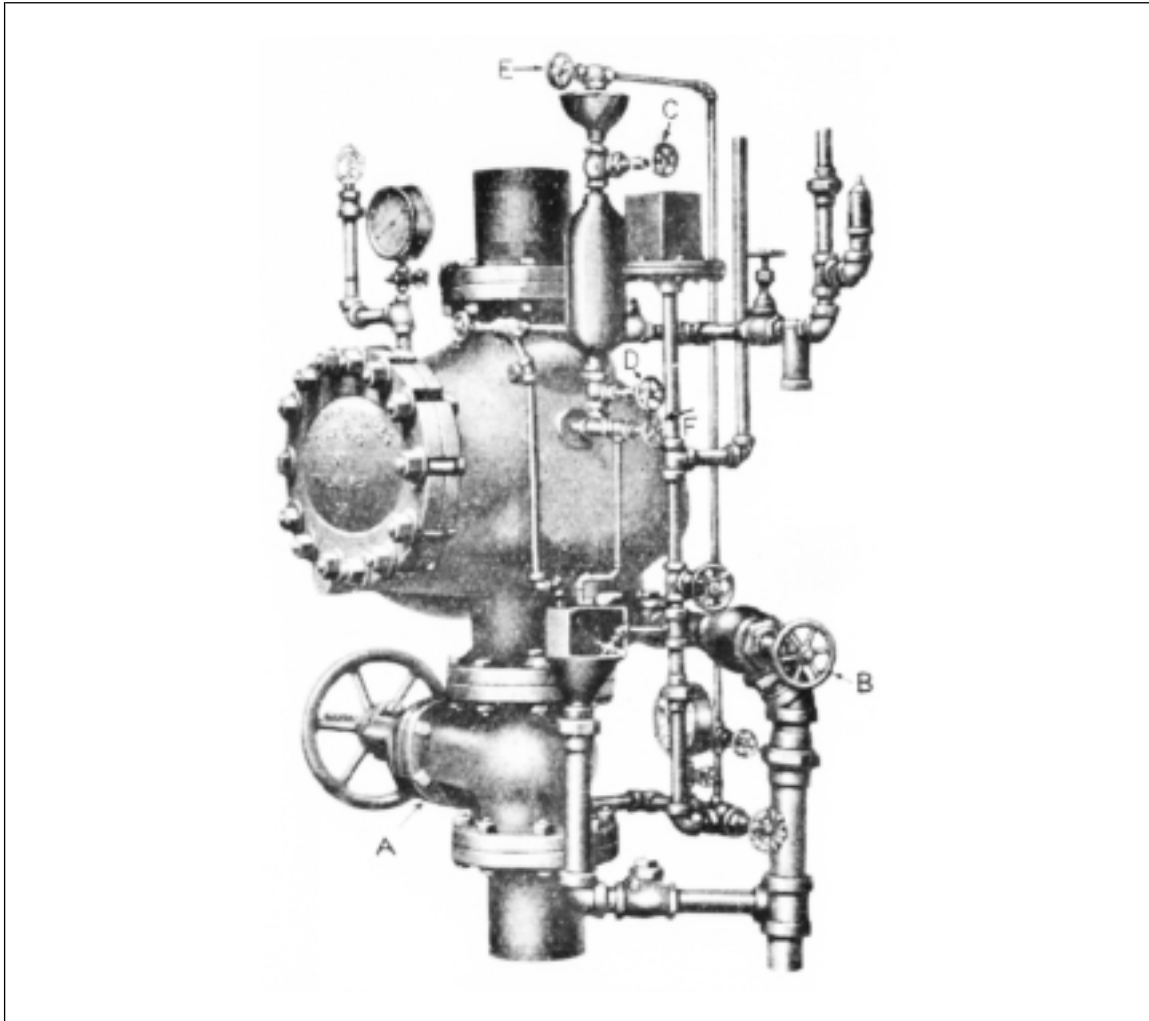

Fig. 16. Crowder Model A dry-pipe valve as installed, with trim.

3. Remove cover of dry valve and lift gravity latch 8 and pull clapper 2 onto its first latch position (6, Fig. 15).
4. Carefully clean the rubber facing 7, air seat 9, and water seat 1.
5. The clapper 2 is released by pushing upward on the rod which extends through the drip valve (5, Fig. 15). It should then be slowly placed on its seat.
6. Replace and tighten cover.
7. Open upper priming valve C and lower priming valve D. Open priming valve E allowing water to flow to the level of test valve F. Close priming valve E, lower priming valve D, and upper priming valve C.
8. Pump air into the system.

2-10R Dry-Pipe, Deluge, Preaction Valves & Accessories

Table 4

Highest Service Water Pressure or Fire Pump Pressure (psi)	Air Pressure (psi)	
	Not Less Than	Not More Than
50	15	25
75	20	30
100	25	35
125	30	45
150	35	50

9. Open Main Control Valve A.
10. Make sure no leakage occurs at drip valve 5.
11. Test the water supply by opening drain valve B.

2.6 FPC Models A and B

FPC Dry-Pipe Valve

MODEL A, 6 INCH - 1922 to 1930

MODEL B, 6 INCH - 1930

Fire Protection Co., Chicago, Illinois

DESCRIPTION

The FPC Models A and B dry-pipe valves (Fig. 17) are differential valves. The water clapper (3, Fig. 17) is attached to the underside of the air clapper (2, Fig. 17) by a ball and socket joint. Both air and water clappers 2 and 3 are carried to the open position by the link clapper arm (7, Fig. 17).

OPERATION

When the dry-pipe valve is in normal set position, the clapper rests on the air and water seat rings (8 and 4, Fig. 17). System air pressure applied to clapper 2 resists water pressure on the water clapper 3 and the valve is held in the closed position. When system air pressure is reduced sufficiently, water pressure will force water clapper 3 open. The clappers 2 and 3 are then out of the waterway or held open by gravity latch (5, Fig. 17).

SETTING

1. Close main control valve A.
2. Open main drain valve B and all draw-off valves and vents at low points throughout the system, closing them when water ceases to flow.
3. Remove the cover and carry the air clapper 2 and water clapper 3 forward to the anti-column latch 5. Thoroughly wipe off the air clapper 2, water clapper 3, water seat 4, and air seat 8. The air clapper 2 and water clapper 3 are now released and carefully placed on their respective seats.
4. As the clappers return to their seats, push the drip valve rod (6, Fig. 17) upward to make sure the rocker arm latch pin (10, Fig. 17) is not holding the air clapper 2 off the air seat 8. Replace cover and bolt down thoroughly.
5. Open upper priming valve C and lower priming valve D, making sure test valve E and air supply valve F are closed. Open priming valve G and fill the body of the valve until water remains in the priming cup H. Close priming valve G and open test valve E, allowing water to flow into drip cup H. When water ceases to flow, test valve E, upper priming valve C, and lower priming valve D.
6. Pump air into the system by opening air supply valve F.

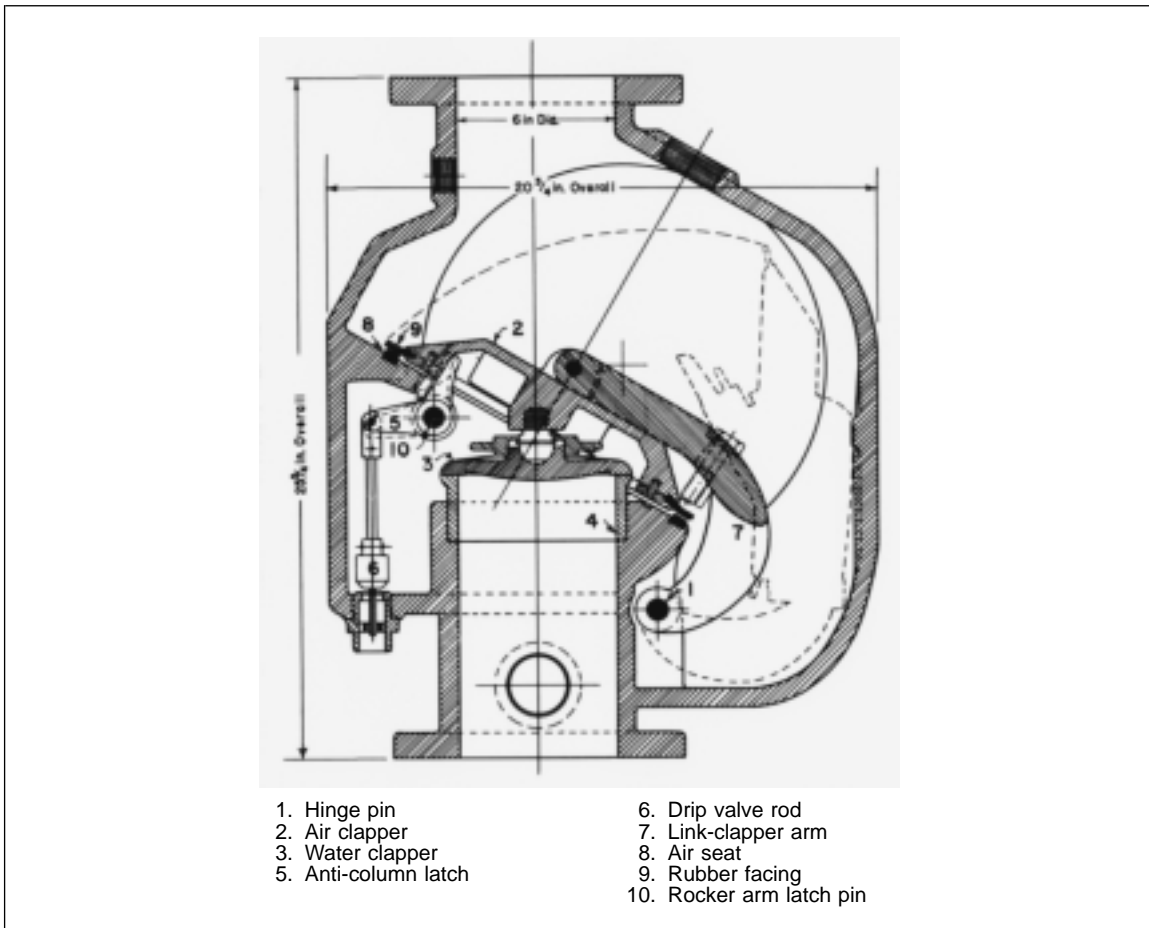

Fig. 17. FPC Model A dry-pipe valve.

Table 5

Highest Service Water Pressure or Fire Pump Pressure (psi)	Air Pressure (psi)	
	Not Less Than	Not More Than
50	15	25
75	20	30
100	25	35
125	30	45
150	35	50

7. Open Main Control A.
8. Make sure no leakage appears at drip valve I.
9. Test the water supply by opening main drain valve B.

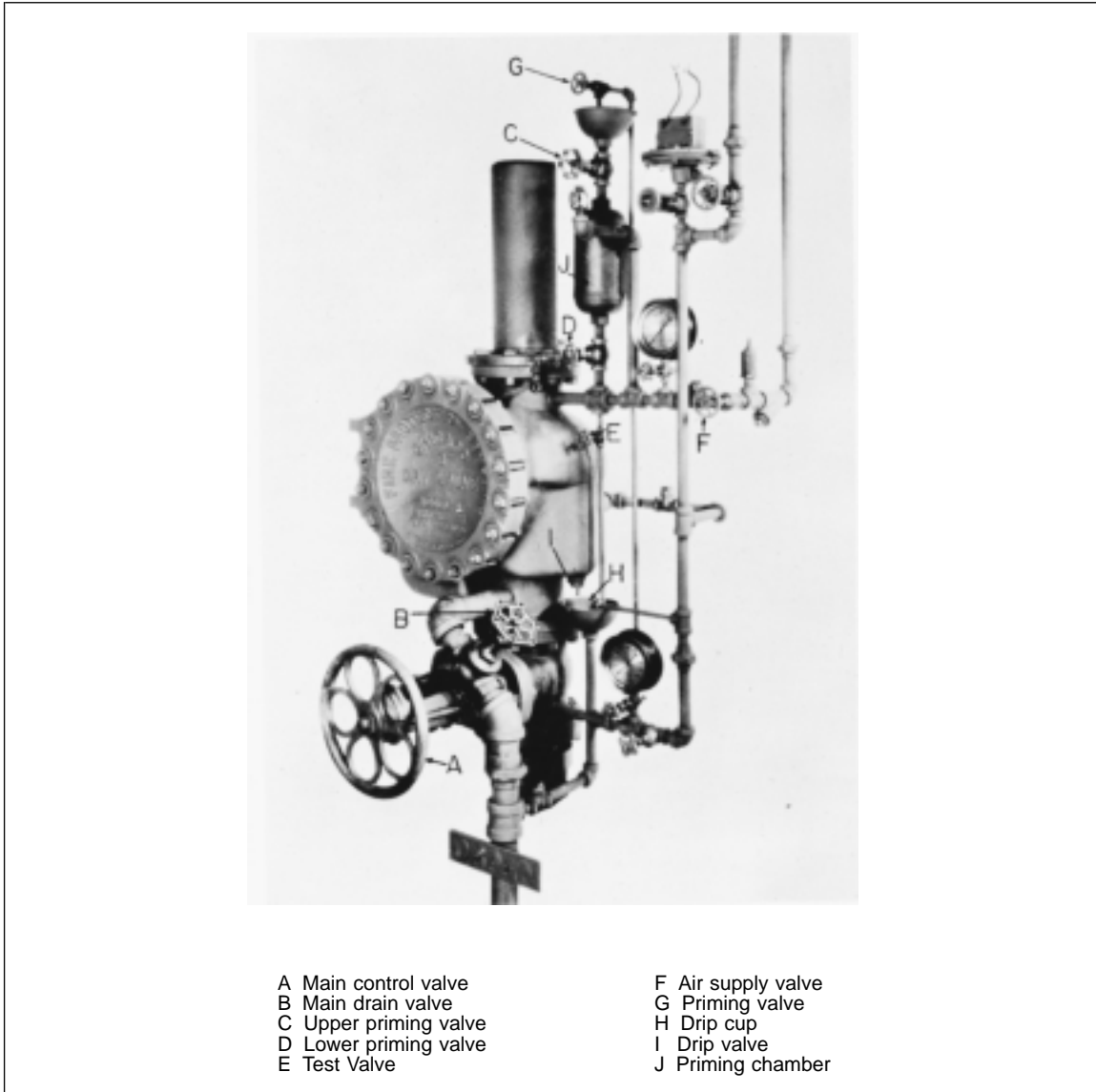

Fig. 18. FPC Model A dry-pipe valve as installed, with trim.

2.7 Globe Models 4, 5, and 6

GLOBE DRY-PIPE VALVE

MODEL 4, 4 AND 6 IN. 1916 TO 1917

MODEL 5, 4 AND 6 IN. 1917 TO 1918

MODEL 6, 4 AND 6 IN. 1918 TO 1921

Norris Industries, Fire & Safety Equipment Div., Newark, N.J. 07114

DESCRIPTION

This is a mechanical valve. Air pressure exerted on the air clapper 10 and auxiliary clapper 11 holds trigger 12 in place. Trigger 12 holds the ball weight 13 as shown in Fig. 19. The position of ball weight 13 is such that the water clapper 5 is held closed.

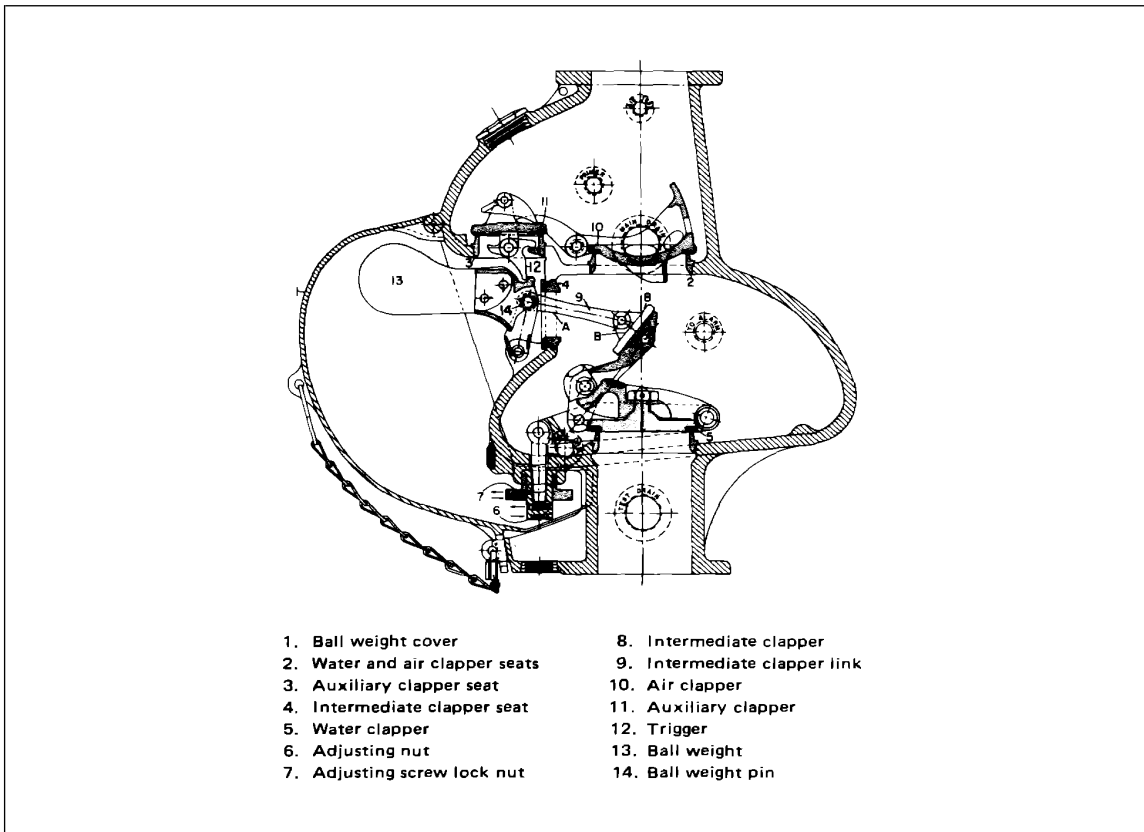

Fig. 19. Globe dry-pipe valve in closed or dry position.

OPERATION

When system air pressure is released the air clapper 10 opens which allows trigger 12 to move thus permitting ball weight 13 to drop (Fig. 20). This causes the intermediate clapper link 9 to pull the intermediate clapper 8 against the intermediate chamber opening. This permits the water clapper 5 to open (Fig. 20).

In general air pressure should not exceed 35 psi and should not be less than 25 psi. The trip point of this valve is, within limits, not affected by the water pressure. The valve is expected to trip at about 10 to 15 psi air pressure.

SETTING

1. Close main control valve A (Fig. 21).
2. Open main drain valve B (Fig. 21). Open all valves and vents to low points throughout the system, closing them when water ceases to flow.
3. Loosen adjusting screw lock nut 7 (Fig. 19) (turn to left slightly, 1/2 turn only).
4. Loosen adjusting nut 6 until the center line B (Fig. 19) of intermediate clapper 8 is opposite the center line A (Fig. 19) of intermediate clapper seat 4.
5. Open the valve cover and carefully clean the water and air clapper seats 2 (Fig. 19), also auxiliary clapper seat 3, and intermediate clapper seat 4, being careful not to damage them. The water clapper 5, intermediate clapper 8, air clapper 10, and auxiliary clapper 11 should also be cleaned.
6. Place water clapper 5 (Fig. 19), intermediate clapper 8, air clapper 10, and auxiliary clapper 11 on their respective seats. Bolt cover in place.

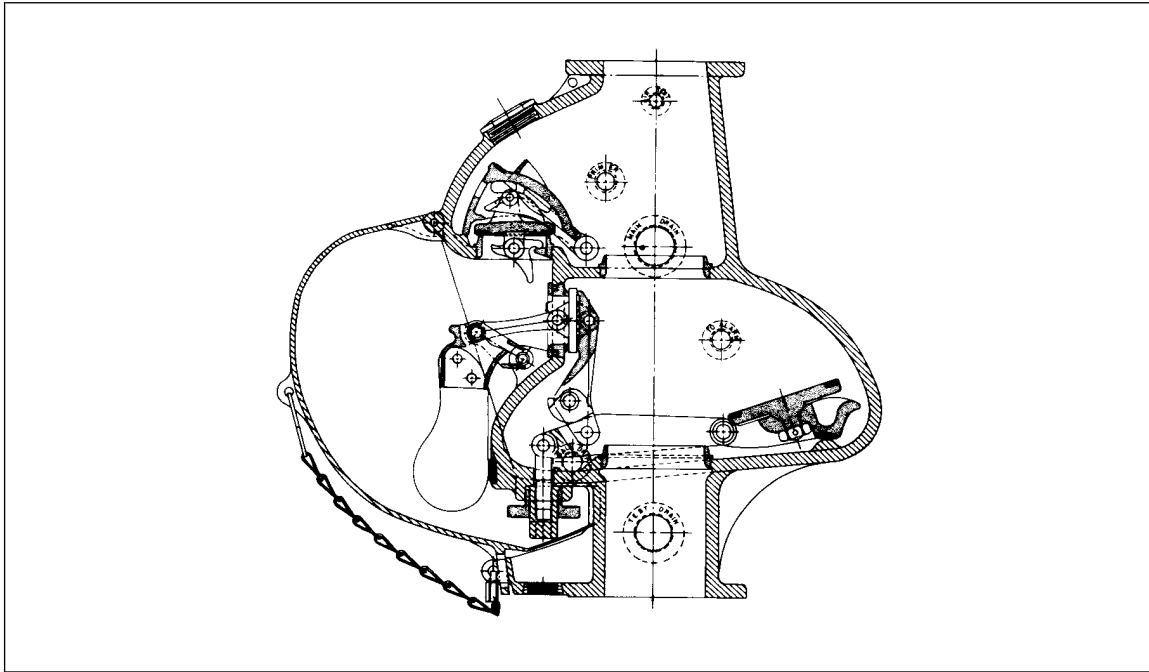

Fig. 20. Globe dry-pipe valve in open or wet position.

7. Prime the valve by opening lower priming valve D (Fig. 21) and upper priming valve E allowing water into the valve. When water flows from priming chamber test valve F, close lower priming valve D. Fill priming chamber C; and when full, close upper priming valve E. Raise the air pressure in the system to the proper value.
8. Lift ball weight 13 (Fig. 19) sufficiently to engage trigger 12 of auxiliary clapper 11. Tighten adjusting nut 6 slightly.
9. Close main drain valve B (Fig. 21) and open main control valve A slightly to allow water pressure against water clapper 5.
10. Slowly tighten adjusting nut 6 (Fig. 19) until no leakage shows at ball drip valve G (Fig. 21). Adjusting nut 6 should be tightened just enough to make water clapper 5 tight against the maximum pressure to which it is liable to be subjected.
11. Tighten adjusting screw lock nut 7 (Fig. 19) and **FULLY OPEN MAIN CONTROL VALVE.**

2.8 Globe Model B

Globe Dry-Pipe Valves

MODEL B 6-INCH (152-MM) 1921 TO 1935

Norris Industries, Fire & Safety Equipment Div., Newark, N. J.

The Globe Model B dry-pipe valve is of the differential type, the air and water clappers being hinged separately. The valve has a straight 6-inch (152-mm) waterway.

To set the valve, release the water clapper 22 (Fig. 22) by raising latch 30, and place the water clapper carefully on its seat. Lift the gravity latch 5 and place the air clapper 4 on its seat. Close cover 2 and admit priming water through the priming chamber to the level of the test valve 66 (Fig. 23) and pump up air pressure. Then open the main gate valve 39. Make sure no leakage occurs past the drip valve 27 (Fig. 22) and that it is free to move. Test the water supply by opening test drain 40 (Fig. 23). Put the priming apparatus in service.

MODEL C 6-INCH (152-mm) 1933-1937

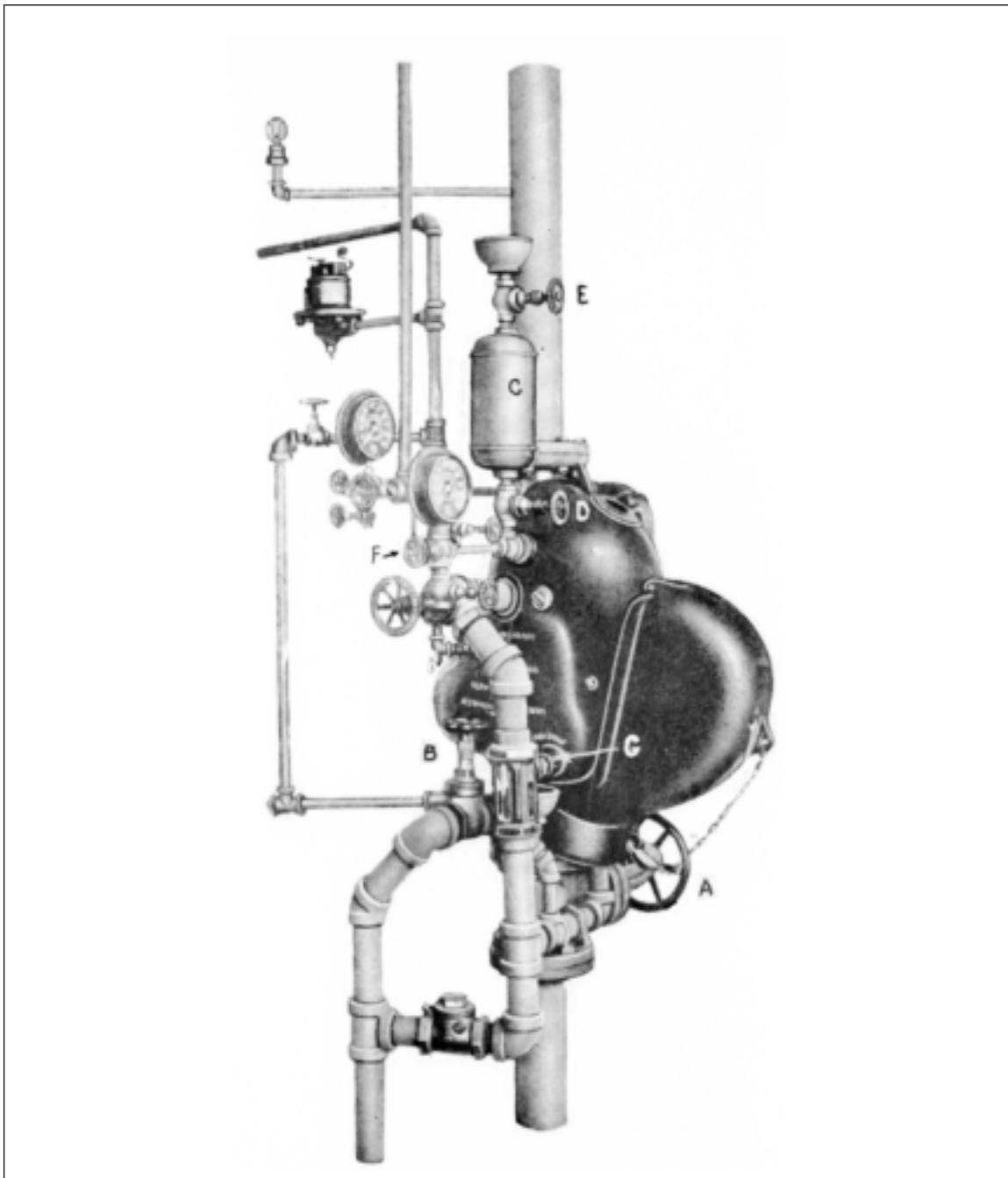

Fig. 21. Globe dry-pipe valve as installed with trim.

The mechanical-type Model C dry-pipe valve is similar to the Model D. This valve is obsolete and should be replaced. See Data Sheet 2-10.

MODEL D 6-INCH (152-MM)

1937 - 1942

(Reference numbers in text refer to Fig. 24 and 25.)

DESCRIPTION

Dry-Pipe Valve

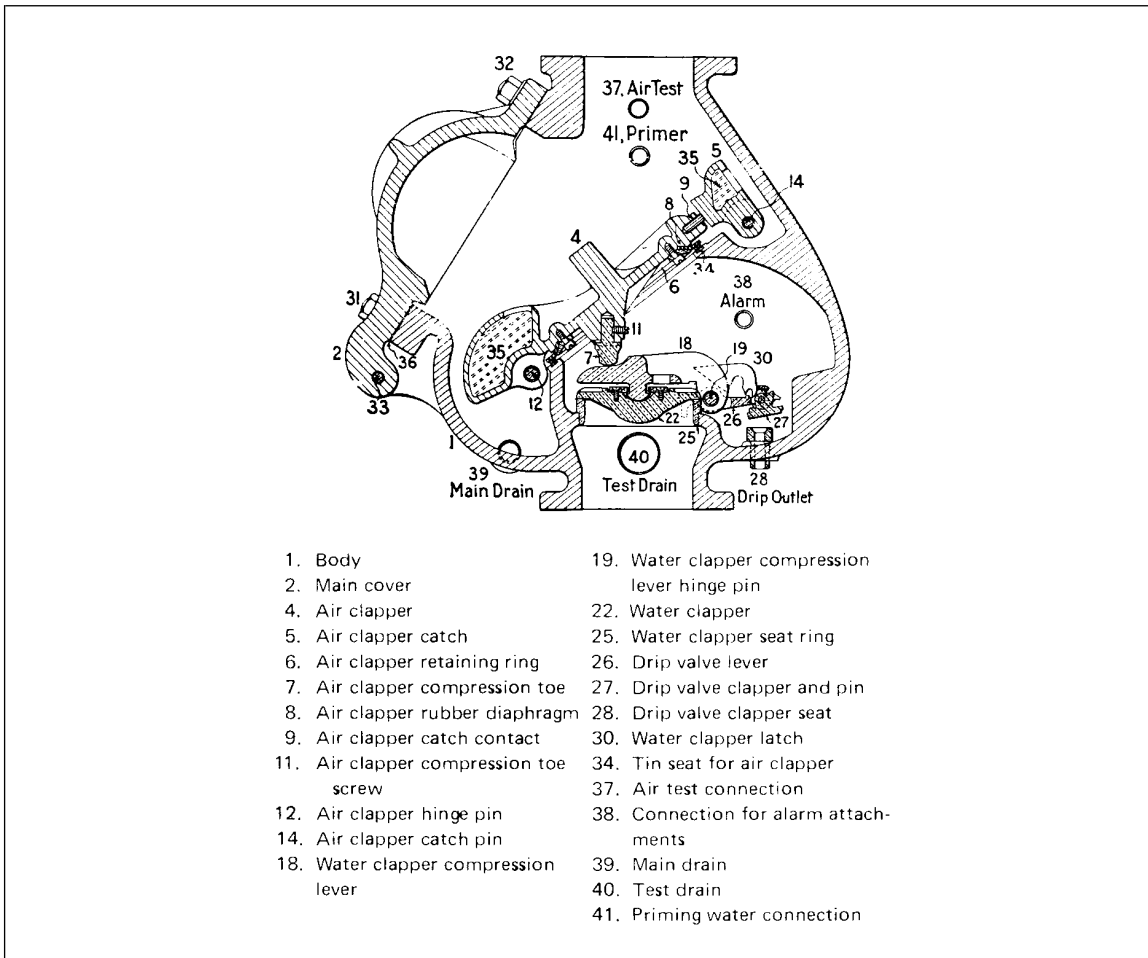

Fig. 22. Model B, in the dry position.

The Globe Model D dry-pipe valve (Fig. 24) is a low pressure, mechanical type having a single swing clapper. A maximum air pressure of 15 to 18 psi (103-124 kPa) (0.1-0.12 b) is maintained regardless of water pressure. At ordinary water pressures the trip point is 5 to 9 psi (34-62 kPa)(0.34-0.62 b). There is no intermediate chamber; therefore, a float drain attachment is required to drain off any water leakage past the clapper into the upper part of the dry-pipe valve body (Fig. 25).

A single swing clapper 3 is held on a flat rubber seat ring 20 by levers 4 & 5 connecting to a mechanical release operated by reduction of air pressure in the dry-pipe system. The rubber seat ring 20 extends into the waterway allowing water pressure to act on its under side, forcing it against the clapper to provide the seal. There is no latch to retain the clapper in wide open position when tripped, but a latch is provided to prevent the clapper from returning to its seat and to permit drainage.

Mechanical Release

The mechanical release consists of a cylindrical tapered release sleeve 12, mounted within a Sylphon bellows 13, four tripping device balls in a retaining ring 29 to form a stop for a shoulder on the plunger stem 37, and a coil spring 26 between the end of the bellows and the release housing.

An Electroac quick-opening device E and control station L with valve seat F in the bypass assembly is provided when necessary to accelerate tripping of the dry-pipe valve Model D and is described in Data Sheet 2-38.

Automatic Alarm Control Valve Assembly

The automatic alarm control valve assembly 36 admits water to the alarm piping when the clapper is raised. It also automatically releases air pressure in excess of 23 psi (159 kPa)(0.16 b). It provides a means for a

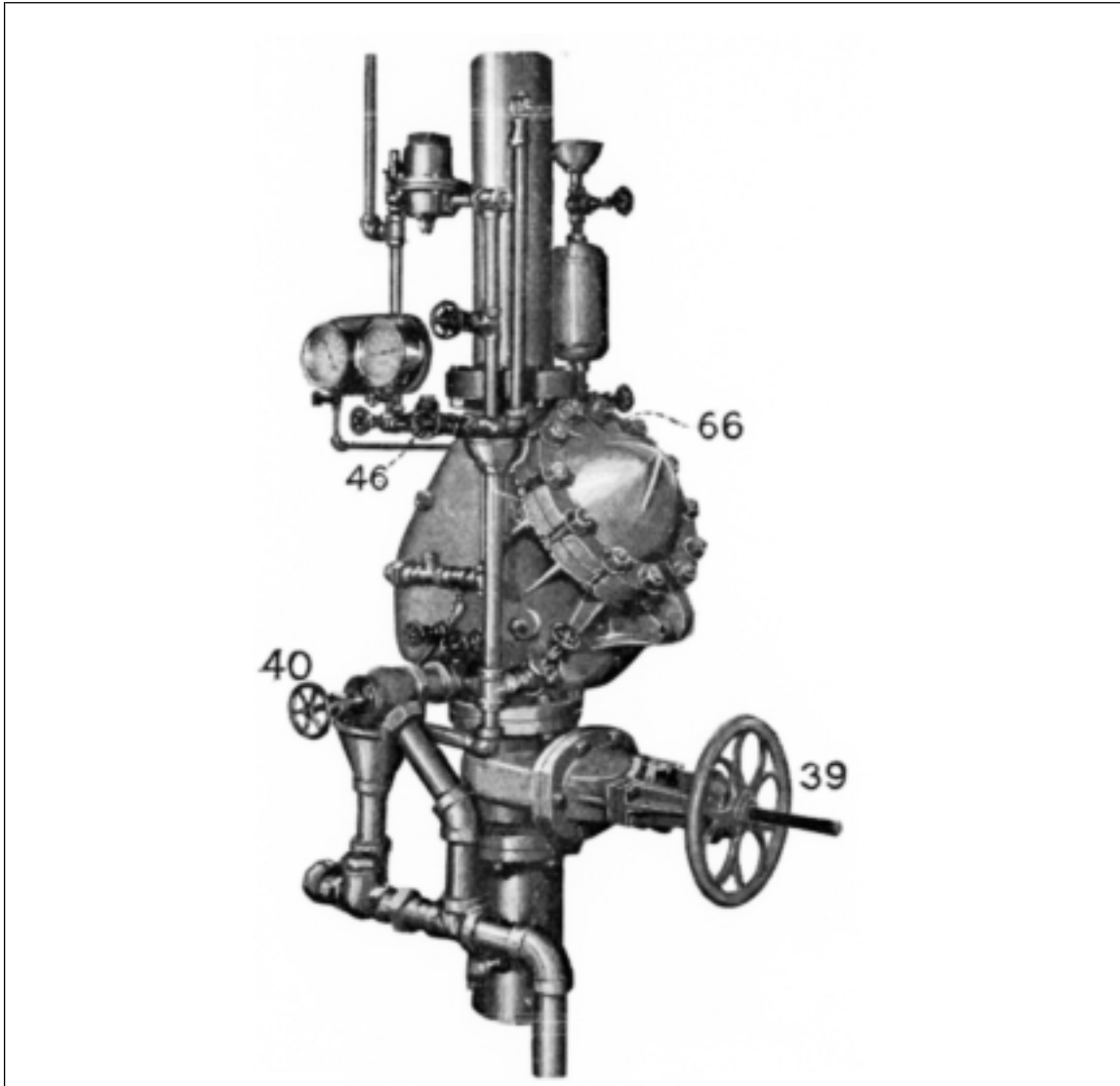

Fig. 23. Model B, external view.

manual test to determine the presence of water above the clapper 3. When making a water column test at a valve equipped with an accelerator, the alarm control valve 44 should be cracked open slowly to prevent accidental tripping of the dry-pipe valve.

OPERATION

When the Model D dry-pipe valve is in the dry position (Fig. 24), the plunger stem 37 bears against lever 5 which holds lever 4 in an upright position to bear on the toe of the clapper 3 and the alarm control valve 44 is closed. System air pressure, passing to the inside of the Sylphon bellows 13 through a small port and inside of the release sleeve 12 through the clearance between the release sleeve 12 and plunger stem housing 43, moves the release sleeve 12 away from the plunger stem housing 43, stretches the Sylphon bellows 13, compresses the coil spring 26, and holds the tripping device balls in the retaining ring 29 against the shoulder of the plunger stem 37 holding the levers 4 and 5 in the dry position.

When the air pressure in the release sleeve 12 is reduced to the trip point (5 to 9 psi) (34-62 kPa) (0.34-0.62 b), the compressed coil spring 26 causes the Sylphon bellows 13 to contract and the tapered portion of the release sleeve 12 to move toward the plunger stem housing 43, allowing the tripping device balls 29 to move away from the shoulder of the plunger stem 37, releasing the force holding levers 5 and 4 in place. Water pressure on the clapper 3 then causes the clapper to open.

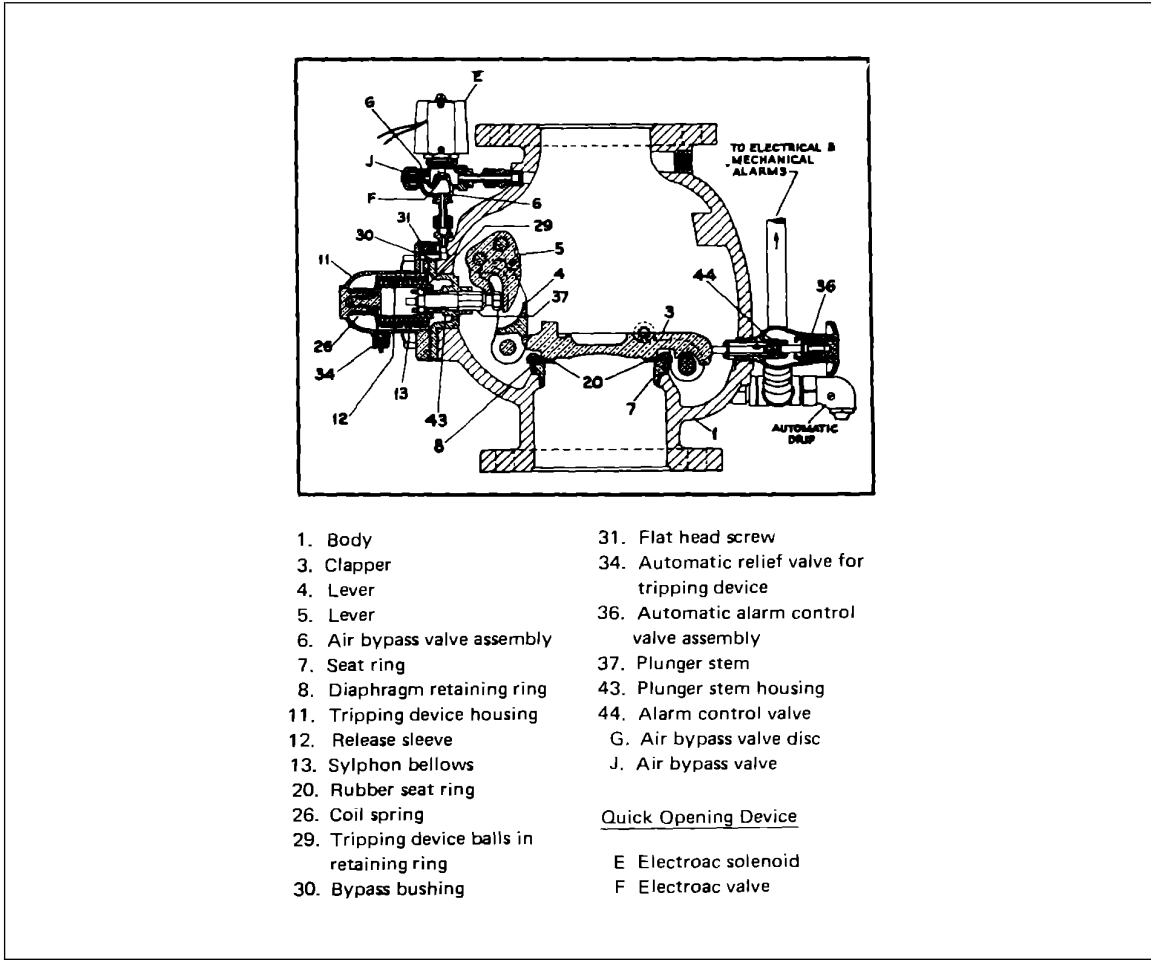

Fig. 24. Model D 6-inch (152-mm), in dry position.

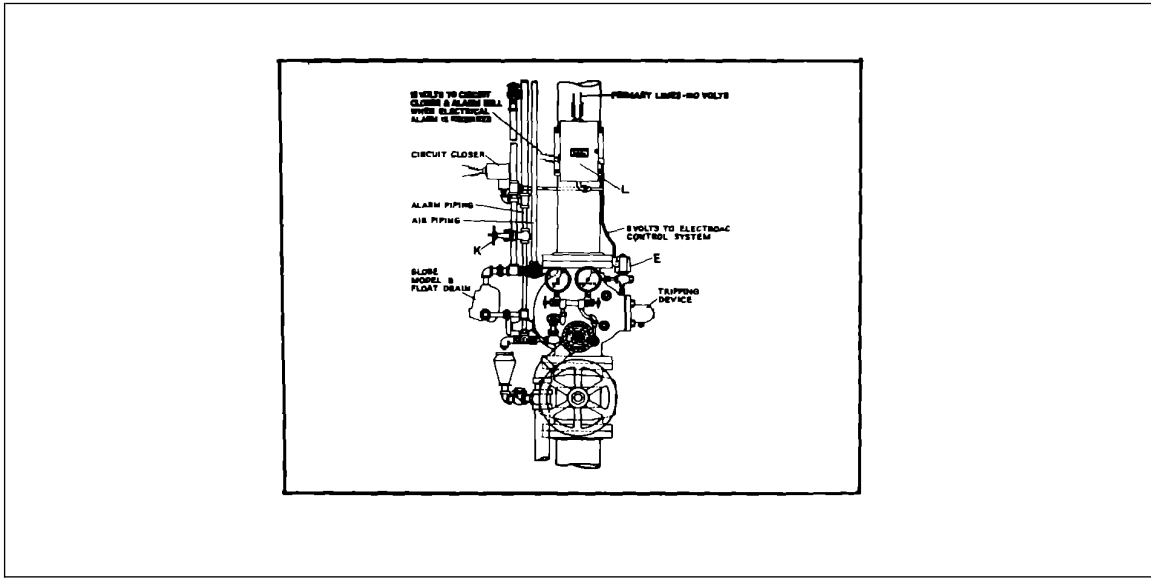

Fig. 25. Model D, equipped with electroac quick opening device, external view.

A "Bypass Valve Assembly" 6 equalizes the high water pressure inside and outside of the Sylphon bellows 13 when the dry-pipe valve trips. At 15 to 18 psi (103-124 kPa)(0.1 - 0.12b), the air pressure bypass valve G remains closed. When the dry-pipe valve trips, the air bypass valve G opens, admitting water outside the Sylphon bellows 13 in the tripping device housing 11 neutralizing the pressure.

A low-velocity check valve in the automatic relief valve for tripping device 34, which vents the release housing to the atmosphere, closes automatically with pressure above 15 to 18 psi (103-124 kPa)(0.1-0.12b).

The spring loaded alarm control valve 44 opens as the clapper lifts, admitting water to alarm piping to operate hydraulic and electric alarms.

SETTING

To set the Model D dry-pipe valve, close the main control valve, drain the system and leave drain valve open, remove the cover, and thoroughly clean the rubber seat ring 20 and clapper 3. Place clapper 3 on its seat, and return levers 5 and 4 to the vertical position to bear on the toe of the clapper. Move the plunger stem 37 to make contact with the internal lever 5. **This valve will not set automatically unless the plunger 37 is "pulled out" by hand.**

The cover is then bolted in place and a maximum air pressure of 15 to 18 psi (103-124 kPa) (0.1-0.12b) is applied above the clapper 3. **The two inch drain valve must be left open while admitting air** to allow possible water leakage by the main control valve to flow off and not build up pressure under the clapper 3 before maximum system air pressure is established. The mechanical release resets automatically as air pressure builds up in the system. The automatic relief valve for tripping device 34 should be tried by hand to be certain that it is relieving any leakage past the Electroac valve F or through air bypass valve G while air is being pumped into the sprinkler system.

If air leakage continues through the automatic relief valve for tripping device 34 after system air pressure reaches 15 to 18 psi (103 - 124 kPa) (0.1-0.12b), system air pressure should be relieved and seats of valves F and G dismantled and cleaned. Air leakage by the alarm control valve 44 can be detected through the automatic drip with control valve K in the pipe line to the water motor gong shut. If leakage continues after the system is pumped up, the automatic alarm control valve assembly 36 should be dismantled and the seat of the alarm control valve 44 cleaned.

FLOAT DRAINS

Float drains are not always provided on Model D valves that were approved by Factory Mutual on the basis that float drains would be provided. Where Globe D dry-pipe valves are found without float drains, they should be provided.

MAINTENANCE

It is most important that moving parts of Model D valve be kept clean. The interior of the valve body should be kept free of rust and tubercles, particularly in the vicinity of the levers 4 and 5 and below the seat ring 7.

Following the annual trip test by the insured, the clapper 3, levers 4 and 5, rubber seat ring 20, and plunger stem 37 should be examined and cleaned. Observe that plunger stem 37 can be moved freely by hand into plunger stem housing 43.

Do not remove the tripping device housing 11 from the body 1. If repairs or replacements are needed, obtain the services of the nearest representative of the Globe Automatic Sprinkler Company.

MODEL AD 4-, 6-INCH (102-, 152-MM)

DESCRIPTION

6-Inch (152-mm) Valve

The 6-inch (152-mm) Model AD dry-pipe valve (Fig. 26) is similar to the Model D dry-pipe valve except that only one lever 4 is used to make contact between the clapper 3 and the plunger stem 37. The electroac quick-opening device and the air bypass valve assembly used with Model D dry-pipe valve is replaced by the Globe Model C quick-opening device which is described in Data Sheet 2-40. Also, with 6-inch (152-mm) Model AD dry-pipe valve, equipment for automatically maintaining the system air pressure within predetermined limits above the trip point may be provided.(See Fig. 27.)

4-Inch (102-mm) Valve

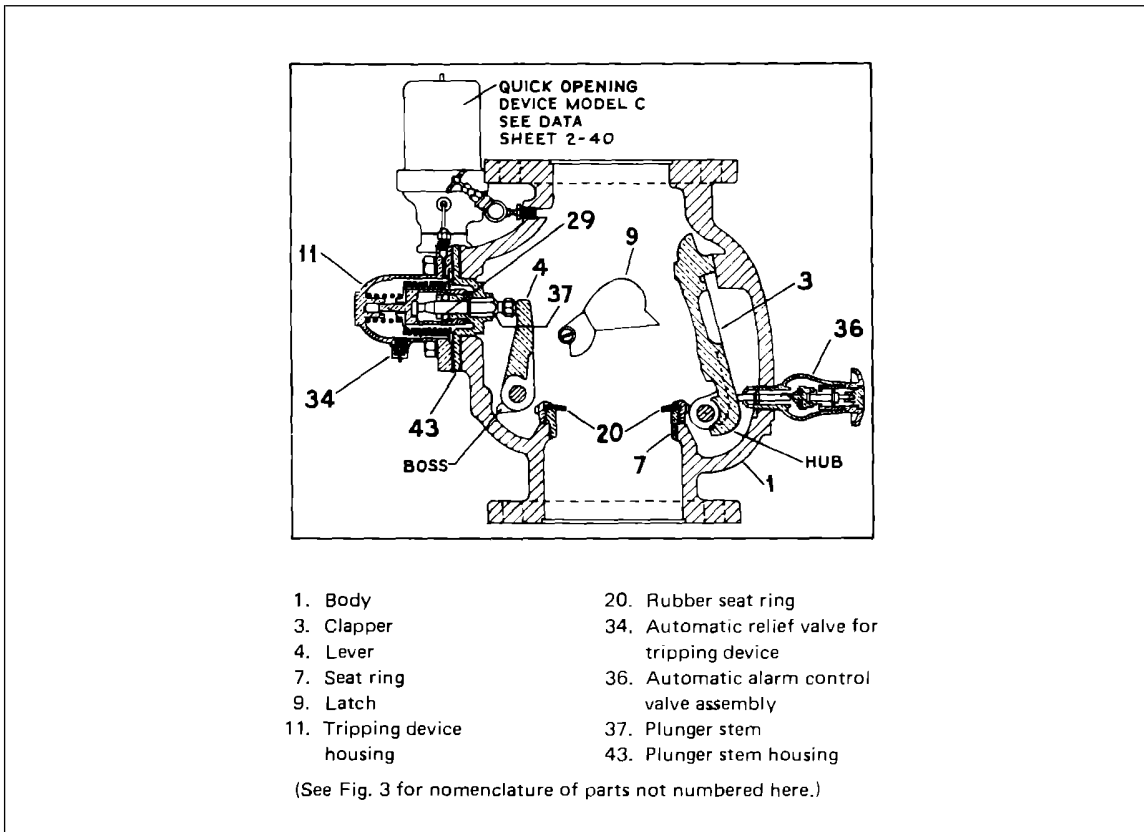

Fig. 26. Model AD 6-inch (152-mm), in the wet position.

The 4-inch (102-mm) Model AD dry-pipe valve is similar to the 6-inch (152-mm) Model AD except that there is no outlet for a quick-opening device.

OPERATION

The operation of the Globe Model AD dry-pipe valve is similar to the Model D dry-pipe valve. At ordinary water pressures, the trip point is 6.5 to 9 psi (45-62 kPa) (0.5-0.6b).

SETTING

The setting of the Globe Model AD dry-pipe valve is similar to the Model D dry-pipe valve.

AUTOMATIC AIR PRESSURE MAINTENANCE EQUIPMENT

Automatic air pressure maintenance equipment is sometimes provided with the 6-inch (152-mm) Model AD dry-pipe valve. See Fig. 27.

A pressure control switch K controls an air compressor unit M or, when air is supplied from a plant air tank, a solenoid valve P in the air supply line. At the normal system air pressure of 16 psi (110 kPa)(0.11b), the pressure control switch K is in the open position. When slow leakage reduces system air pressure to 12 psi (83 kPa)(0.83b), control switch K closes and starts motor of air compressor unit M or causes solenoid valve P to open and supply air to the system.

Where independent air compressors are used, the pressure control switch K is furnished with an automatic air release valve L to relieve back pressure in the air supply line so the compressor can start under zero load. The automatic air release valve L is operated by levers from the pressure control switch K, and is closed under normal conditions and open when the compressor is operating or the system pressure is low. The air compressor and electric motor may be of any required type and capacity.

An oil trap and air capacity chamber O is located in the air supply line to prevent oil entering the system piping or other equipment.

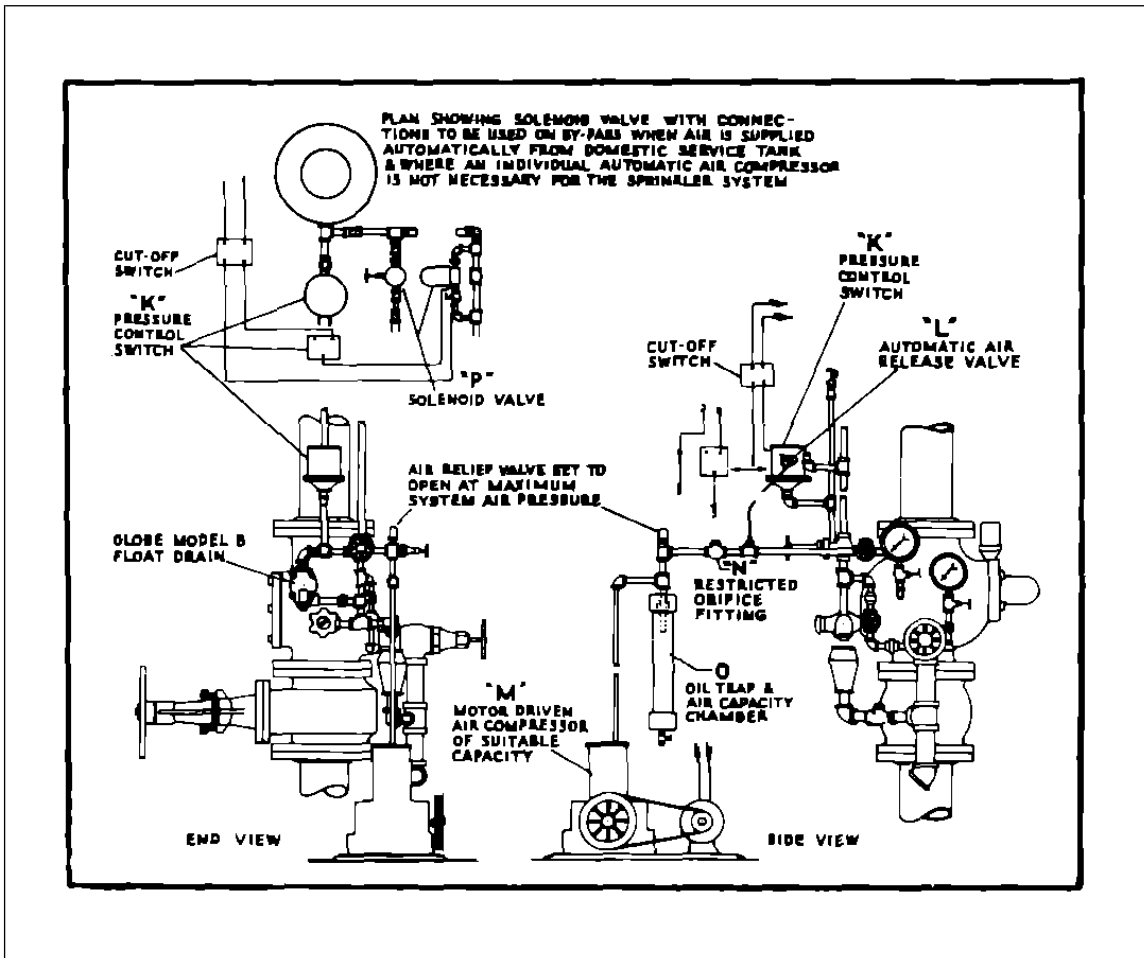

Fig. 27. Automatic air pressure maintenance device, connected to Model AD dry-pipe valve.

To prevent failure of the dry-pipe valve by supplying air at a rate equal to or greater than the discharge from one sprinkler, a 1/8-inch (3.2-mm) restricted orifice fitting N is provided in the air supply line. This fitting is a 1/4 inch (6.4-mm) globe valve with a hex head cap in place of the usual bonnet, stem, and valve disk assembly. An air relief valve set to open at maximum system air pressure is also provided in the air supply pipe to vent excess air pressure.

FLOAT DRAINS

Float drains (Fig. 27) are not always provided on Model AD valves that were approved by Factory Mutual on the basis that float drains would be provided. Where Globe AD dry-pipe valves are found without float drains, they should be provided.

MAINTENANCE

It is most important that moving parts of Model AD valve be kept clean. The interior of the valve body 1 should be kept free of rust and tubercles particularly in the vicinity of the boss of lever 4 and the hub of the clapper 3.

Following the annual trip test by the insured, the clapper 3, lever 4, rubber seat ring 20 and plunger stem 37, should be examined and cleaned. The plunger stem 37 should be free to be moved, by hand, into the plunger stem housing.

Do not remove the tripping device housing 11 from the body 1. If repairs or replacements are needed, obtain the services of the nearest representative of the Globe Automatic Sprinkler Company.

MODIFICATIONS TO MODELS A AND AD

Due to difficulties experienced with Models D and AD dry-pipe valves, the manufacturer began, in June 1951, a program to modify these valves as difficulty was experienced with individual valves (Fig. 28).

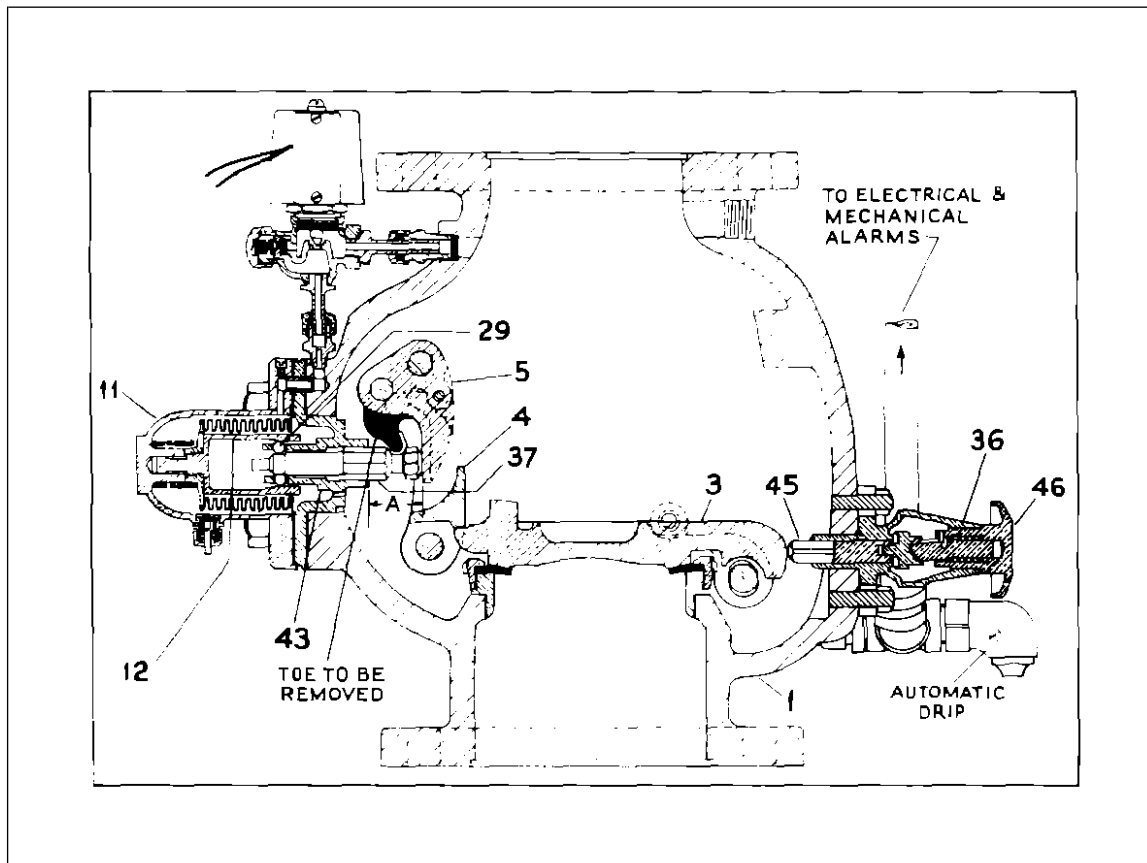

Fig. 28. Modifications to Models D and AD Valves Dry Position.

All modified valves will have the numeral "5" and the year of modification stamped on the tripping device housing 11. The numeral "5" will also be stamped on the body 1 and on the cover plate.

In case of failure of Globe D or AD dry-pipe valves, a recommendation for reconditioning and modification by the manufacturer is in order. When it is necessary to return Model D or AD valves to the factory for reconditioning, the following changes will be made.

MODEL AD VALVES

1. The clearance between the release sleeve 12 and the plunger stem housing 43 will be increased where these pieces make a sliding contact with each other.
2. That portion of the release sleeve 12 in contact with the bronze balls 29 will be chrome plated and polished. The plunger stem 37 will also be chrome plated and polished.
3. The number of bronze balls 29 in the plunger stem housing 43 will be increased from four to five.
4. The automatic alarm control valve assembly 36 will be changed so that this assembly will be flanged and bolted to the body 1.
5. The plunger 45 in the automatic alarm control valve assembly 36 which bears against the clapper 3 will be increased in diameter.
6. A ½-inch (12.7-mm) drain will be provided on the side of the body 1 for testing for any accumulation of water above the clapper 3. **The provision of this drain does not eliminate the Factory Mutual requirement for a float drain attachment.**

MODEL D VALVES

The changes 1 through 6 listed above for Model AD valves will be made.

The toe on lever 5 will be removed. The purpose of this toe was to pull the plunger stem 37 out when the lever 4 was set in position. Without the toe on this lever 5 the Model D valve can be set in the dry position, the same as Model AD valve, by pulling out lever 4 and then pulling the plunger stem 37 out by hand.

INVESTIGATION WHEN MODELS D AND AD FAIL TO TRIP PROPERLY

MODEL AD VALVES

Refer to Fig. 26 and 28.

After removing the cover plate carefully observe the position of clapper 3, lever 4, and plunger stem 37 **before attempting to move them**. Note and report the following data:

1. Does lever 4 bear on the toe of clapper 3 to prevent it from raising?
2. What is the distance to the nearest ⅛ inch (3.2-mm), between plunger stem housing 43 and the end of the plunger stem 37? See dimension "A", Fig. 28.
3. Is the plunger stem 37 free to move in and out of the plunger stem housing 43 when moved by hand?
4. Is lever 4 free to move when moved by hand?
5. Does the plunger 45 of the automatic alarm control valve assembly 36 bind to prevent the clapper 3 from raising?
6. Is clapper 3 free to be raised manually?
7. After releasing the spring tension on plunger 45 by rotating hand wheel 46 counterclockwise, can the plunger 45 be rotated by hand?

2-10R Dry-Pipe, Deluge, Preaction Valves & Accessories

MODEL D VALVES

Follow the procedure for Model AD valves. In addition, determine if the lever 5 is free to be moved by hand.

Dimension A should be:

Table 6

Size and Model of Dry-Pipe Valve	Dry Position,		Wet Position,	
	In.	(mm)	In.	(mm)
6-in. (152-mm) D or AD	1½	(38)	¾	(19)
4-in. (102-mm) AD	1¾	(35)	¾	(19)
Modified 6-in. (152-mm) D or AD	1¾	(44)	¾	(19)
Modified 4-in. (102-mm) AD	1¾	(35)	¾	(19)

MODEL F 6 in. (152-mm) 1953 - 1966

MODEL F-2 4 in. (102-mm) 1966 - Date 6 in. (152-mm)

Table 7. Air pressure to be maintained with Model F and F-2 dry-pipe valves

Water Pressure		MODEL F			
		Air Pressure			
		Not Less Than		Not More Than	
psi	(kPa)(b)	psi	(kPa)(b)	psi	(kPa)(b)
30	(207)(2.1)	8	(55)(0.55)	12	(83)(0.83)
50	(345)(3.5)	10	(69)(0.69)	20	(139)(1.4)
75	(517)(5.2)	15	(103)(1.0)	25	(172)(1.7)
100	(689)(6.9)	20	(139)(1.4)	30	(207)(2.1)
125	(862)(8.6)	25	(172)(1.7)	35	(241)(2.4)
150	(1034)(10.3)	30	(207)(2.1)	40	(276)(2.8)
		MODEL F-2			
30	(207)(2.1)	15	(103)(1.0)	20	(139)(1.4)
50	(345)(3.5)	20	(139)(1.4)	25	(172)(1.7)
75	(517)(5.2)	25	(172)(1.7)	30	(207)(2.1)
100	(689)(6.9)	30	(207)(2.1)	35	(241)(2.4)
125	(862)(8.6)	35	(241)(2.4)	40	(276)(2.8)
150	(1034)(10.3)	40	(276)(2.8)	45	(310)(3.1)
175	(1207)(12.1)	45	(310)(3.1)	50	(345)(3.5)

DESCRIPTION

The Models F and F-2 dry valves (Fig.29) are combination differential and mechanical type valves having a single rubber-faced swing clapper covering both the air and water seats. Air pressure should be maintained in accordance with Table 1. At 30 psi (207 kPa)(0.21b) water pressure, the trip point is 4 psi (28 kPa)(0.28b); at 60 psi (414 kPa)(0.41b) the trip-point is 9 psi (62 kPa) (0.62b); and at 90 psi (621 kPa)(0.62b) the trip point is 14 psi (97 kPa)(0.97b). Trip points at other pressures can be determined by constructing a curve.

The Model F-2 differs from the Model F in the design of the clapper and compression plate assembly. The operating characteristics of the two valves are similar. The Model F-2 clapper and compression plate were designed to replace that assembly in the Model F valves.

A single clapper 3 having a rubber facing rests on a seat ring 2 having an annular groove. This annular groove is vented to atmosphere through atmospheric discharge tube 16 and a velocity type drip and forms part of a passage to the intermediate chamber 38 which is between the top of clapper 3 and the compression plate

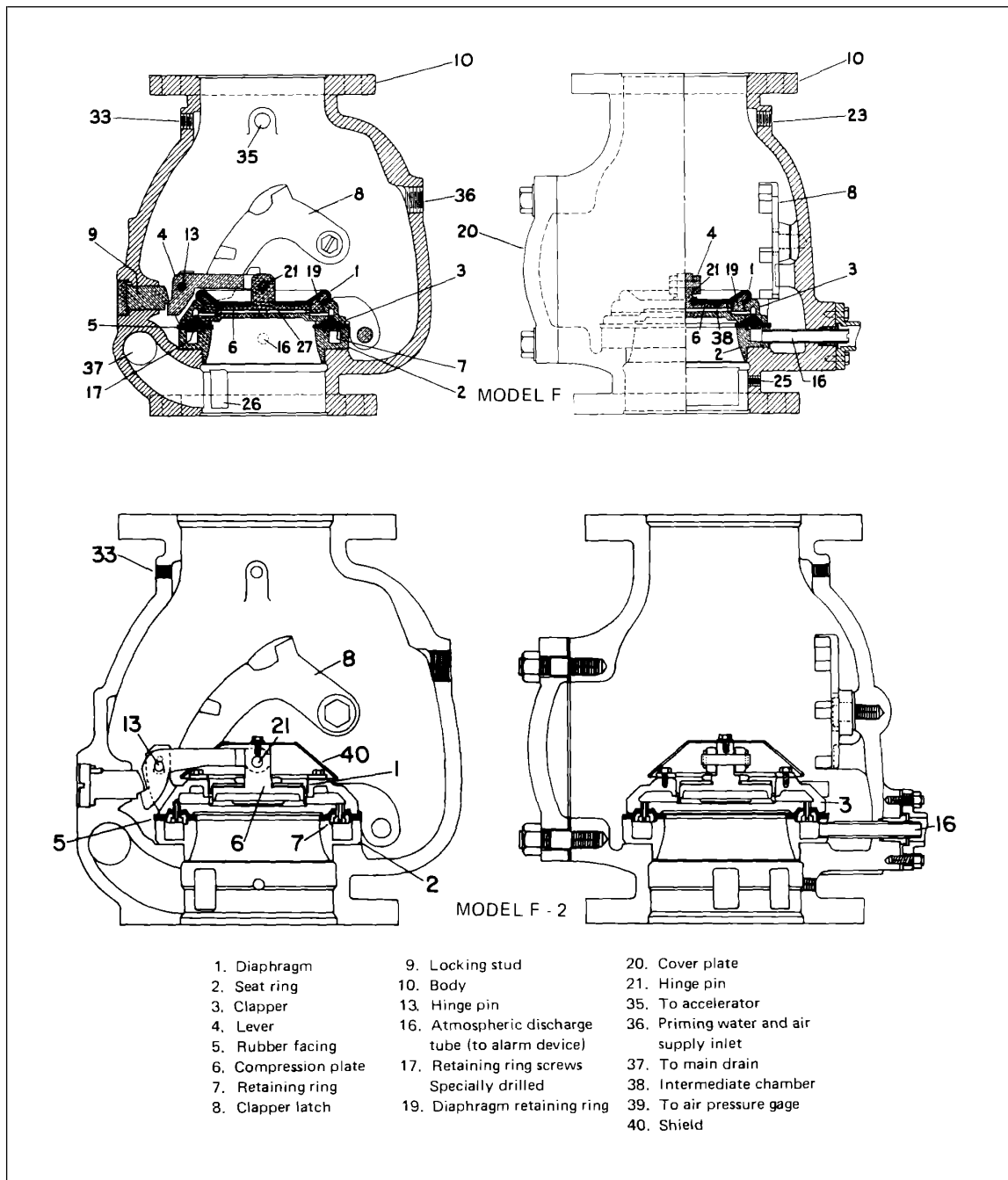

Fig. 29. Models F and F-2 Valves in the Dry Position.

6. Holes through the retaining ring screws 17 provide a means for maintaining atmospheric pressure in the intermediate chamber 38 since the hole forms part of a passage from this chamber to the annular groove in seat ring 2.

The compression plate 6 is held in place on top of clapper 3 by a diaphragm 1 which is attached by diaphragm retaining ring 19. The compression plate 6 is connected by a hinge pin 21 to one end of a lever 4 whose upper end has a toe which latches under locking stud 9 in the valve body 10 to hold the clapper 3 on seat ring 2. The fulcrum point of lever 4 is attached to the clapper 3 by a hinge pin 13, and the lever is free to pivot at this point and at the connection to the compression plate 6.

2-10R Dry-Pipe, Deluge, Preaction Valves & Accessories

A clapper latch 8 is provided to prevent clapper 3 from returning to its seat and to permit drainage. Clapper latch 8 will allow the clapper to return to any of three positions depending upon how far it was opened by the flow of water through the valve.

Priming water is introduced into the dry-pipe valve through chamber C and priming valve H (Fig. 30).

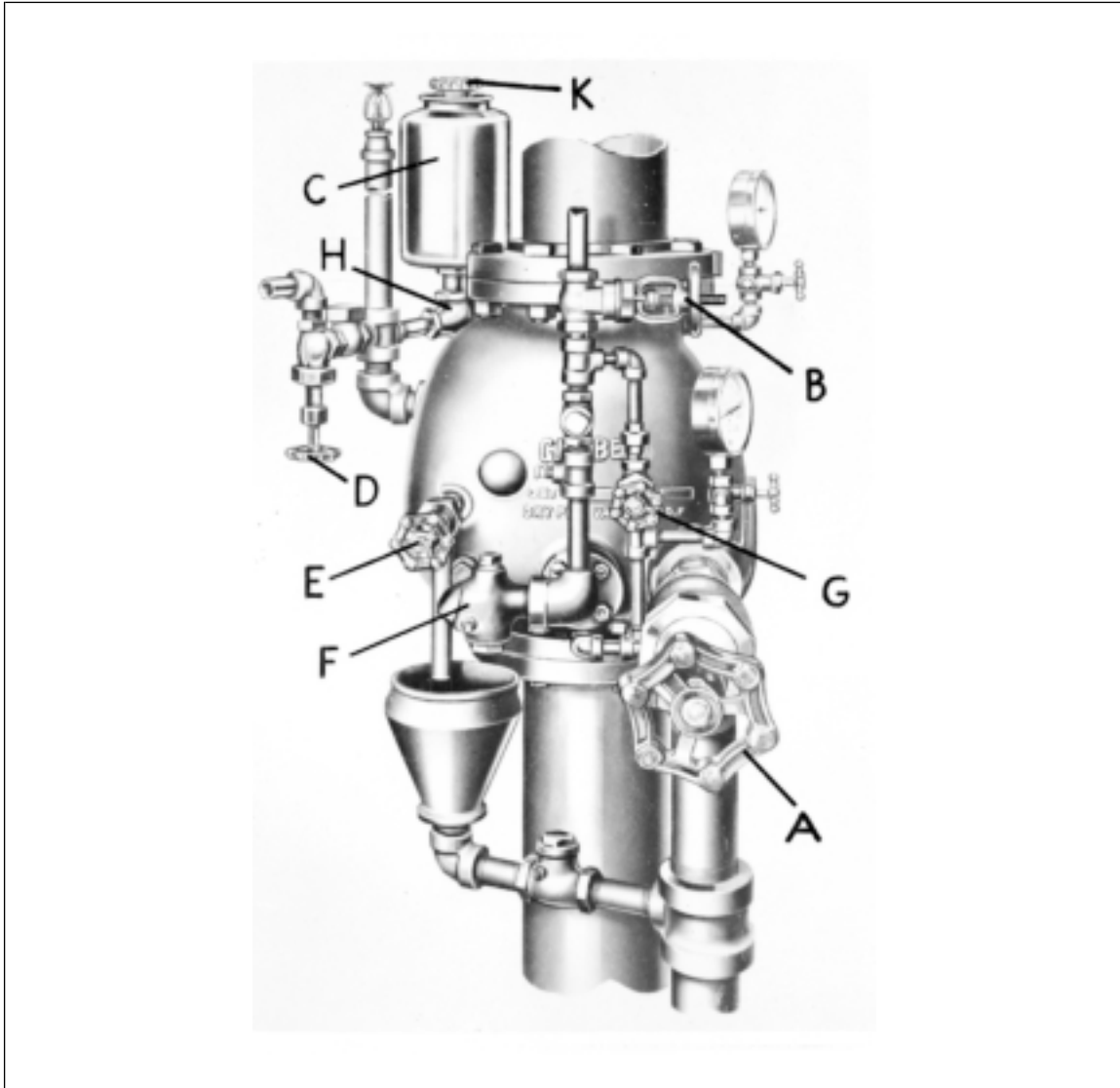

Fig. 30. Model F, external view.

OPERATION

When the Model F dry-pipe valve is in the dry position (Fig. 29), the toe of lever 4 bears against locking stud 9. System air pressure acting on the top of diaphragm 1 which has atmospheric pressure beneath it, keeps lever 4 from pivoting from its fulcrum point at hinge pin 13. Thus clapper 3 is held on seat ring 2.

When the air pressure in the system is reduced to the trip point, the water pressure on the underside of the clapper 3 acting through the fulcrum at hinge pin 13 causes lever 4 to pivot and lift compression plate 6 which is no longer held down by the system air pressure.

SETTING

Refer to Fig. 29 and 30.

To set the Model F dry-pipe valve, close the main control valve and attach red tag, drain the system and leave drain valve open, remove the cover plate 20 and thoroughly clean seat ring 2 and rubber facing 5 and run a small wire through the holes in the twelve retaining ring screws 17. Unlatch clapper 3 and place it on seat ring 2. Lift lever 4 at its connection to compression plate 6 to make sure that both lever 4 and compression plate 6 are free to move. Clean off any tubercles around locking stud 9 and any encrustations on or around lever 4 which might cause binding.

Bolt cover plate 20 in place. Remove hand wheel cap K from the priming chamber C and open priming valve H. Prime the dry-pipe valve by pouring approximately three quarts of water through the opening in the top of priming chamber C. The proper priming water level can be determined by opening priming water test valve E to indicate whether or not the water has reached this level and to allow any excess to drain out through this valve.

When the excess priming water has drained out close priming water test valve E and priming valve H and replace handwheel cap K. Open air inlet valve D and build up air pressure in the system in accordance with Table I and then close this valve. Open the main control valve until water starts to flow from drain valve A. Close drain valve A slowly and open the main control valve to the wide position.

Make a drain test through the drain valve A. After determining that the main control valve is wide open, remove red tag and apply seal. Record data regarding valve tripping on Factory Mutual Form 57, *Tripping Record of Dry Pipe Valve*.

MAINTENANCE

It is most important that moving parts of the Model F and F-2 valves be kept clean. The interior of the valve body should be kept free of rust and tubercles particularly in the vicinity of locking stud 9 and the hinge point of lever 4 and clapper 3.

Following the annual trip test, the clapper 3, lever 4, seat ring 2, and the holes in machine screws 17 should be examined and cleaned. Lift lever 4 and compression plate 6 by hand to observe that diaphragm 1 has not hardened sufficiently to prevent tripping of the valve.

2.9 Grimes Model A

Grimes Dry Pipe Valve Model A 6-Inch

1927 TO 1941

Raisler Corp., New York, N.Y.

DESCRIPTION

The Grimes Model A dry pipe valve is of the differential type and the air and water clappers are hinged separately. The valve has a venturi throat tapering from a 6-inch inlet to a 5-inch water seat. The outlet is full 6-inch.

2-10R Dry-Pipe, Deluge, Preaction Valves & Accessories

SETTING (Figs. 31 and 32)

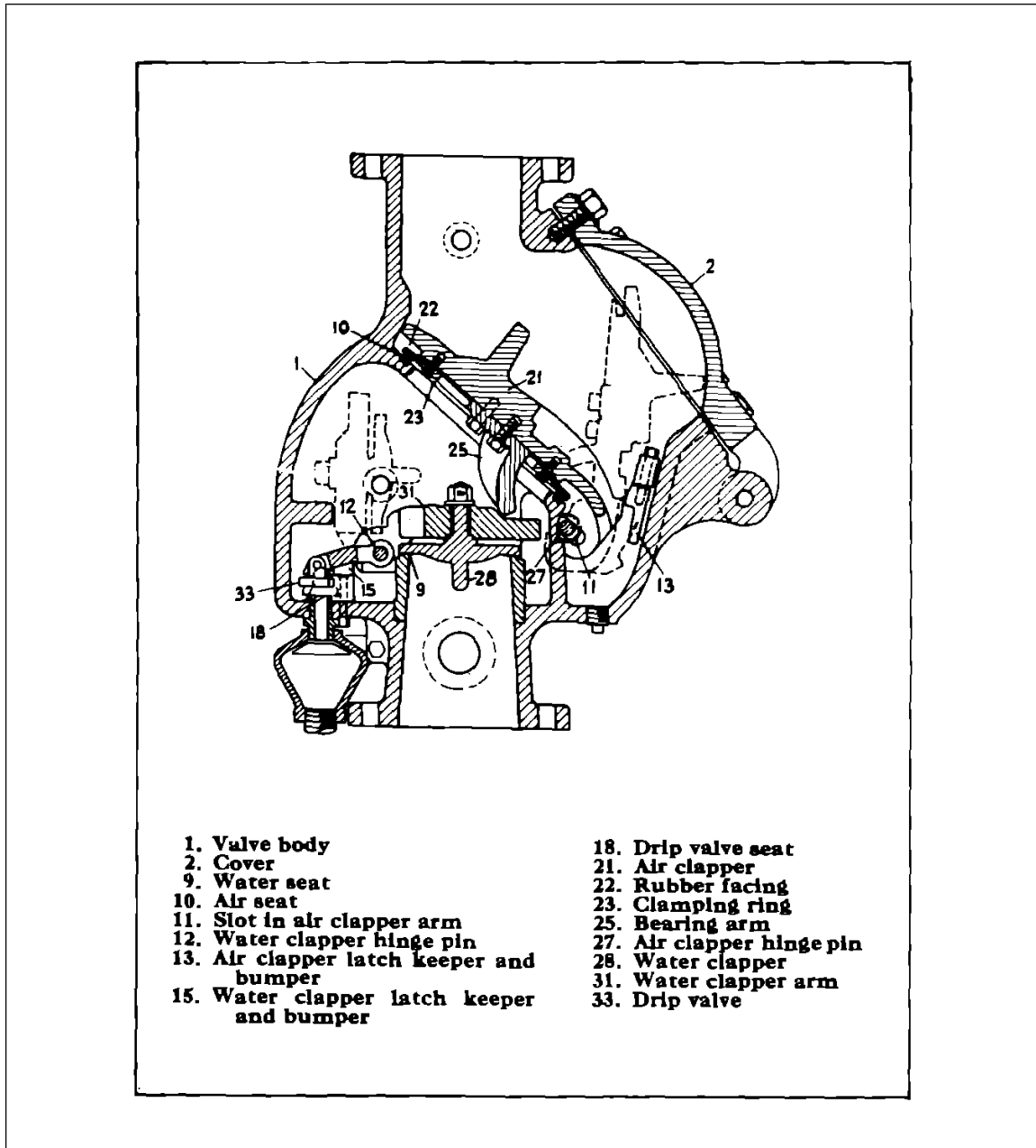

Fig. 31 - Model A - Internal View

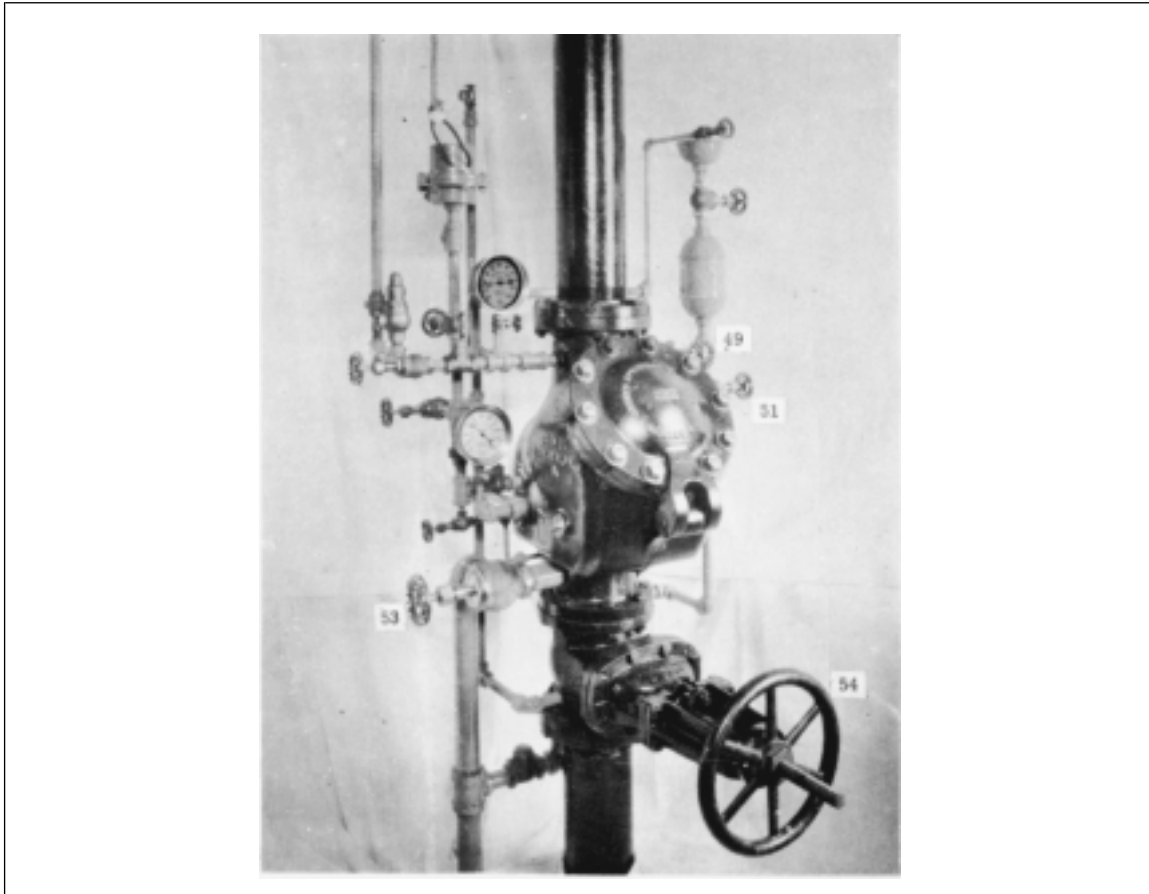

Fig. 32 - Model A - External View

To set the Model A dry pipe valve, close the main control valve (54), drain the system and leave drain valve (53) open, remove the cover (2) and thoroughly clean the rubber facing (22), air seat (10), water seat (9) and the face of the water clapper (28). Lift the water clapper (28) upward by its handle as far as it will go and then bring forward and place on its seat (9). Lift the air clapper (21) upward by its handle and carry to its seat (10). Replace the cover (2) and admit priming water through the priming chamber until water appears at test valve (51) with valve (49) closed. Pump up the required air pressure. Open the main control valve (54) slowly and at the same time close drain valve (53). Make sure there is no leakage of water through drip valve (33) and that it is free to move. Test the water supply by opening drain valve (53). Then seal in the open position all manual water control valves that have been operated.

GRINNELL DRY PIPE VALVE MODEL 12

3-, 4-, 5-, 6-INCH

1890 - 1907

Grinnell Corp., Providence, R. I.

This dry pipe valve is obsolete (Data Sheet 2-10) and should be replaced with an approved valve.

DESCRIPTION

The Grinnell No. 12 dry pipe valve is of the differential type. The waterways at the inlet and outlet ends are 6-inch. The waterway through the valve is obstructed by the bronze cone-shaped clapper (A). This clapper (A) forms a water and air valve, its upper edge being provided with a rubber diaphragm which seats against a block-tin air clapper seat (B). The valve has a latch (D) to prevent water columning.

2-10R Dry-Pipe, Deluge, Preaction Valves & Accessories

SETTING

To set the Model 12 dry pipe valve, close the main control valve, drain the system through drain valve (F) and the drain valve below the dry pipe valve and leave the drain valves open. Remove the hand hole plugs (J) and lift clapper (A) until it rests on latch (D). Thoroughly clean the water and air seats and the face of the rubber air diaphragm. Pull out latch (D) thus seating clapper (A) on its water and air seats. Hold latch (D) back by any convenient method until the dry pipe valve is primed and on air pressure. Close drain valve (F) and prime the dry pipe valve through valve (G) by means of the priming cup. Close valve (G) and pump up the necessary air pressure. Release latch (D) and make sure it is free to move. Open the main control valve slowly and at the same time close the drain below the dry pipe valve and note if any water leaks past the water seat. If no water is noted, cover the fine threads of the hand holes with a mixture of graphite and heavy oil to prevent corrosion and replace the hand hole plugs.

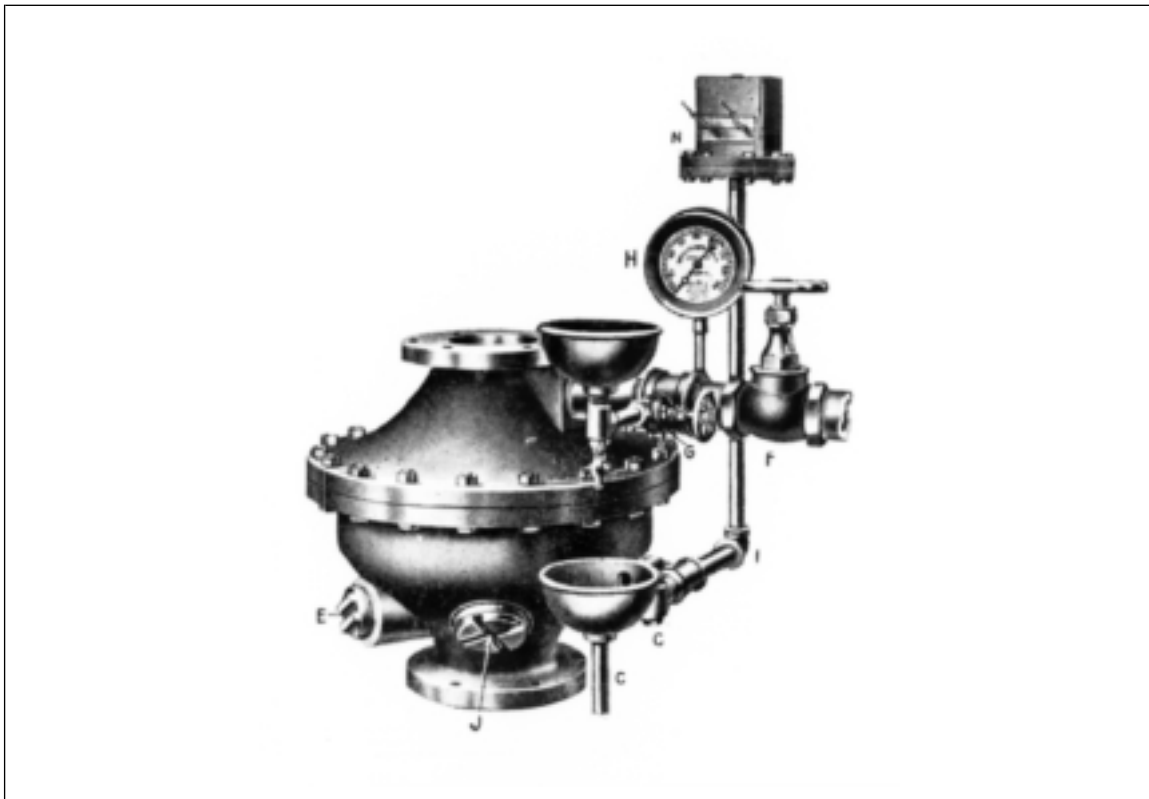

Fig. 33. Grinnell No. 12 dry pipe valve

Special Precautions and Instructions

The following information and instructions are for those cases in which Model 12 dry pipe valves must be continued in use temporarily.

If threads for hand hole plugs (J) are badly corroded or worn, the plugs may blow out when the valve trips. The threads for latch cover plug (E) may also be corroded.

Carefully note if latch (D) is installed as shown above and bears against the water seat when the clapper is raised. If this latch is inverted, it may prevent the clapper from opening.

Determine if the vertical movement of the clapper assembly was retarded by contact between the guides (L) on the clamping ring and corrosion which forms at the priming water level, by turning the clapper one quarter turn and lifting.

Examine water and air seats. When the water seat has been reground many times, latch (D) may be forced above the rim of the water clapper, holding the valve down and preventing tripping.

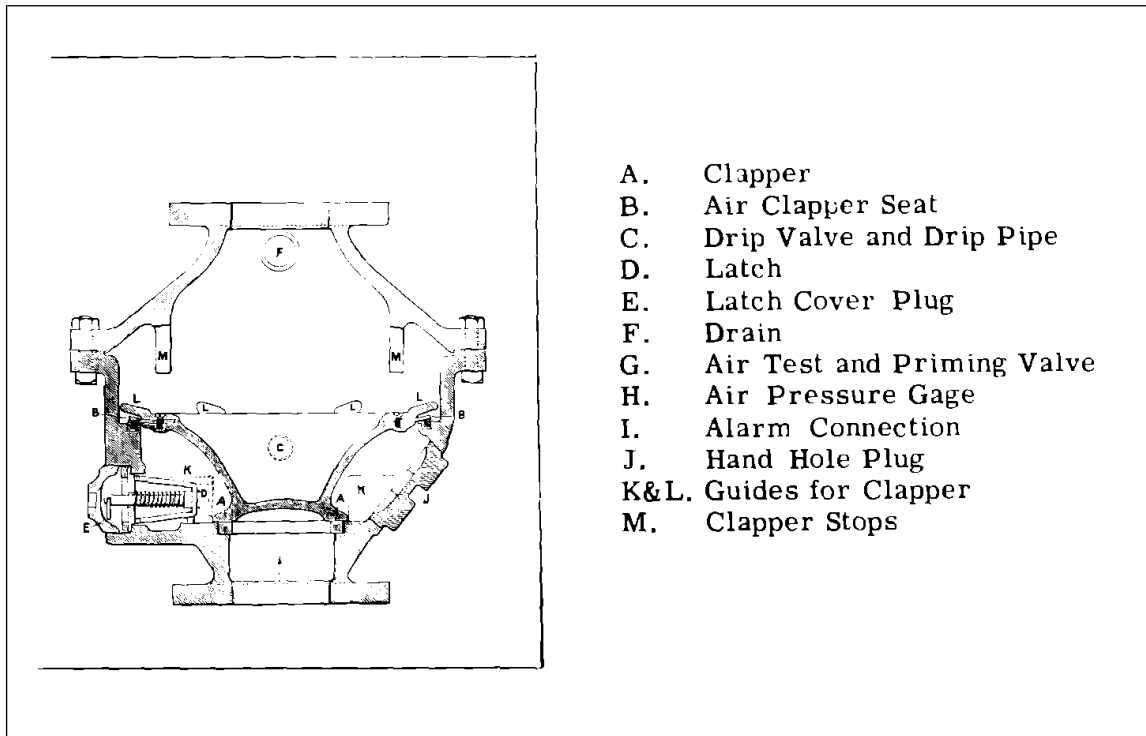

Fig. 34. Grinnell No. 12 dry pipe valve

If the clapper (A) appears to bind when lifted during the examination of the valve interior through the hand holes, or the valve has not been removed from the line for complete overhauling within three years, or there is any doubt regarding condition of the interior of the body above the clapper seat (B), the valve should be removed from the line for a thorough internal examination. The interior above the air clapper seat (B) cannot be examined satisfactorily through the hand hole openings. Insert a filler piece and maintain the sprinkler system on water while the valve is being examined. If the valve must be returned to service temporarily, the valve interior should be cleaned thoroughly and painted with a light coat of red lead and linseed oil, carefully avoiding seats, latch mechanism, and bronze clapper.

2.10 Grimes Model B

Grimes Model B Dry-Pipe Valves

6 in. - 1959 to Date

4 in. - 1962 to Date

Raisler Corporation, New York, N.Y.

DESCRIPTION

The Model B dry-pipe valve is a differential type valve, having a single rubber-faced clapper with the valve venturi tapered from the inlet to the water seat. The outlet is a full 4 in. or 6 in. depending on valve size.

OPERATION

When the system air pressure is released, the clapper moves upwards and rotates out of the waterway. The clapper arm and gravity hinge nuts and bolts rotate and fall into the slots provided in the gravity hinge latch bracket.

SETTING

Refer to Figures 35, 36, and 37.

1. Close valve controlling water supply to dry pipe valve.

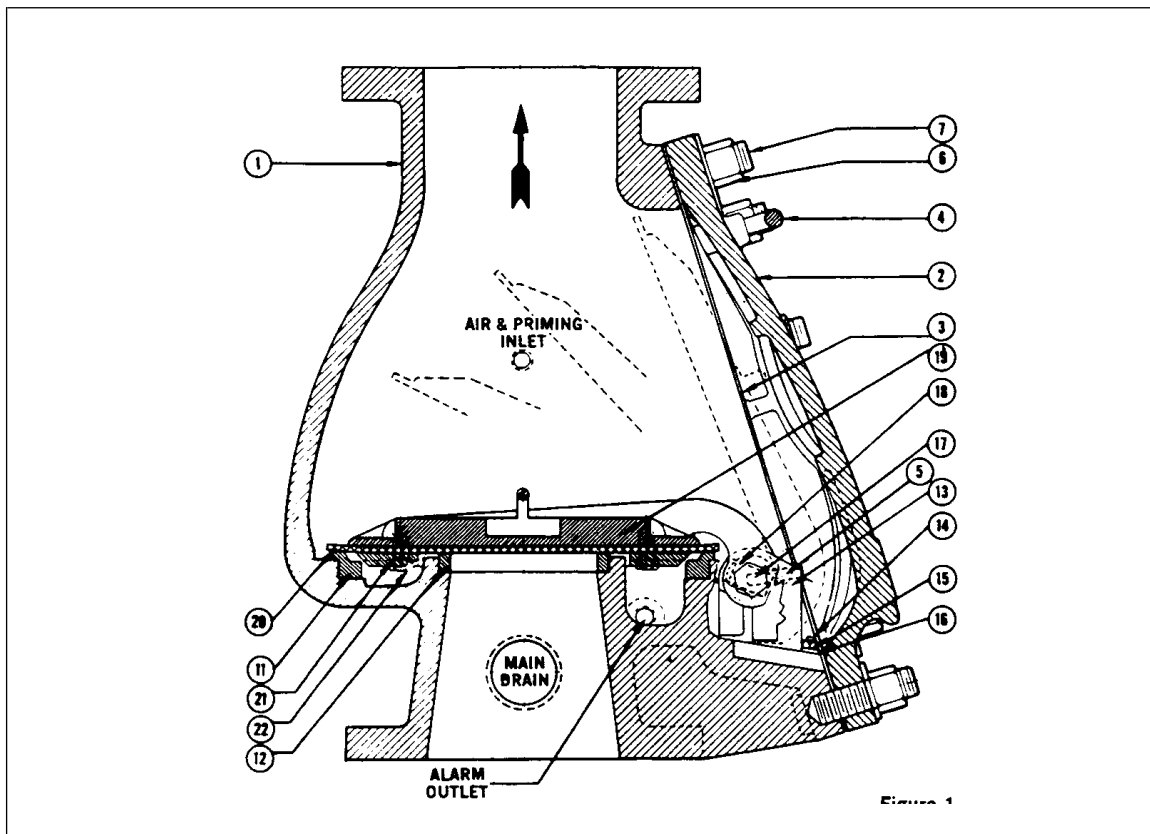

Fig. 35. Grimes Model B Dry-Pipe Valves

2. Open main drain valve (41) and all other drain valves and vents at low points throughout the system. Close when flow of water has stopped. Push in plunger of mechanical drip valve (35) to force ball from seat.
3. Remove cover plate (2). Expose clapper rubber facing (20), and seats (11) and (12) to view, loosen the two hinge bolts (17) about five turns, at the same time holding the bolts (17) hard against the clapper arms, thus causing the hinge nuts (18) to slip out of the channels in the clapper arms. With bolts (17) and nuts (18) now resting loosely in the gravity hinge latch bracket (13), slowly rotate clapper (19) off the seats, allowing the hinge nuts (18) to slip down the elongated slots of brackets (13) to the bottom of the slots. Continuing to rotate the clapper will cause the hinge nuts (18) to ride up in the slots so that the bolts (17) and nuts (18) will act as a support while cleaning or removing the rubber facing.
4. After examining the rubber facing, the clapper should be rotated carefully back to position on the seats to restore the valve into service. Set hinge nuts (18) securely in the clapper arm channels, and make bolts (17) and nuts (18) tight. The edge of the clapper rubber facing should be checked to see that it completely covers the seat ring. Double check to be sure that both bolts (17) and (18) are tight with nuts in clapper arm channel. If nuts are not tight in channels, the cover will not go on valve.
5. Place in position gasket (3) and cover (2) and tighten cover nuts.
6. Open valves (47), (43), (42) and (49) and run water into the dry pipe valve through priming cup (34) until the water flows into the drip cup (32) from valve (47), indicating water is at the proper level. Close valves (49), (43), and (42), then (47) after water stops flowing.
7. Open valve (44) and pump a few pounds of air into the sprinkler system. Close valve (44).
8. Open separately drain valves and vents located at low points of the system to force out any accumulated water closing them when flow of water stops.
9. Open valve (44) and pump sufficient air into the sprinkler system to hold the dry pipe valve in the closed position against the maximum water pressure in accordance with Table 8. Close valve (44).

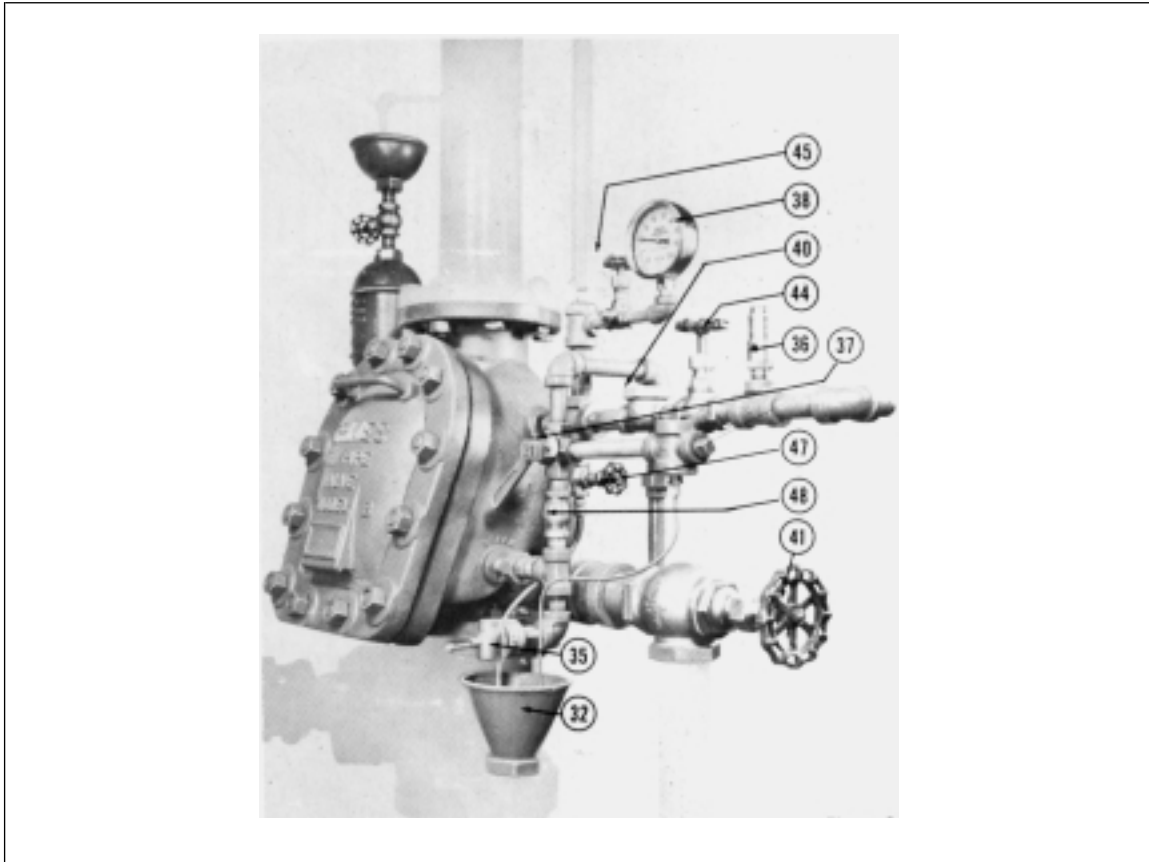

Fig. 36. Grimes Model B Dry-Pipe Valves

10. Observe if water leaks through mechanical drip valve (35) into drip cup (32). If no leak occurs, air seat is tight.

Table 8

Maximum Water Pressure (psi)	Air Pressure (psi)	
	Minimum	Maximum
Below 50	15	—
50	15	25
75	20	30
100	25	35
125	30	45
150	35	50

2.11 Grinnell Models A and A-2

Grinnell Dry-Pipe Valve

Model A, 3 ½ Inch (89 mm)* 1929-1930

Model A-2, 3 ½ Inch (89 mm)* 1930-1931

Grinnell Fire Protection Systems Co., Providence, R. I.

Grinnell Models A (Fig. 38) and A-2 (Fig. 39) dry-pipe valves are basically mechanical dry valves with a combination of air and water pressure holding water clapper 1 closed. In set position water pressure enters chamber 3. This pressure acts on diaphragm 2 forcing strut assembly 4 to hold water clapper 1 closed. A groove in water seat 5 conducts any water leaking past the seat to drip valve C (Fig. 40). Air pressure in the

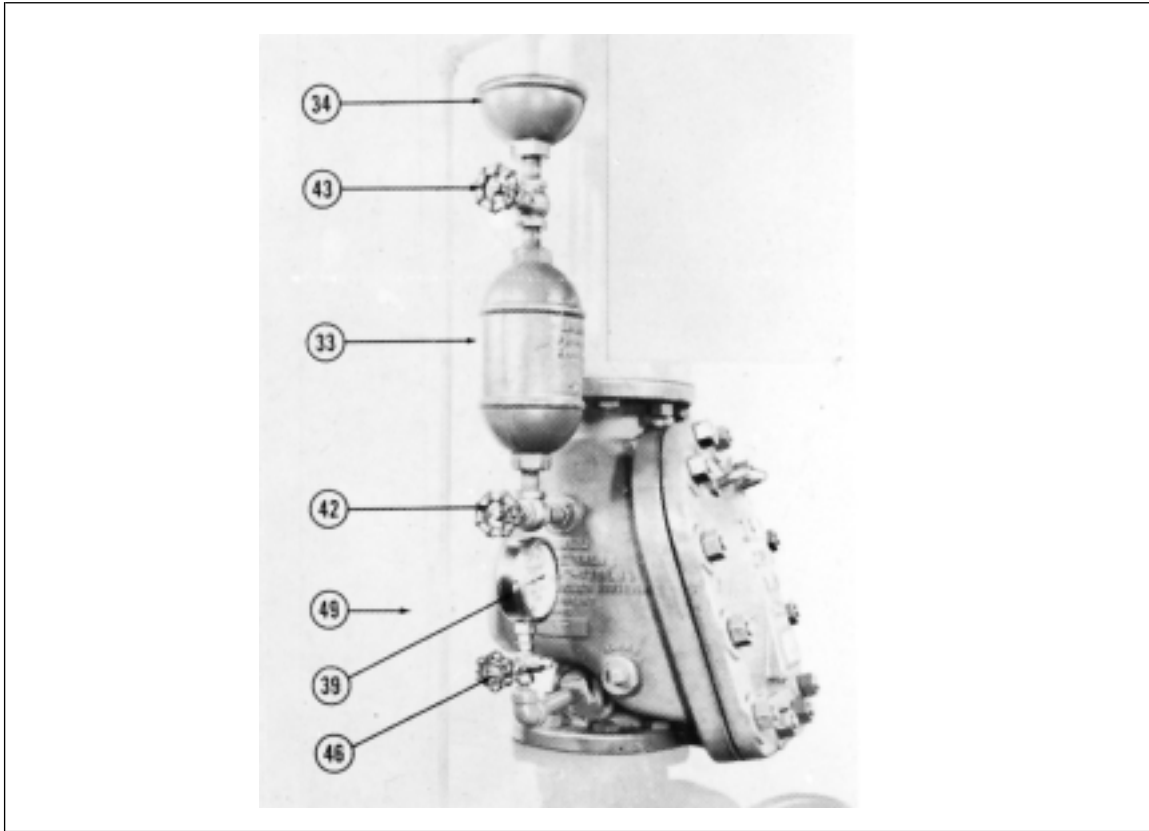

Fig. 37. Grimes Model B Dry-Pipe Valves

system is exerted under bellows 6 which is attached to latching mechanism 7 and 8. Air pressure holds bellows 6 up, engaging the latching mechanism which holds auxiliary valve (formerly known as air check valve) 9 closed.

When system air pressure is reduced, bellows 6 drops releasing latching mechanism 7 and 8 allowing auxiliary valve 9 to open. This permits water pressure in chamber 3 to escape. Water clapper 1 is now free to open. The trip point of this valve is about 9 psi (62 kPa)(0.62b) and is independent of the water pressure.

SETTING

1. Close the main control valve supplying water to the system.
2. Close valve D (Fig. 40) controlling water to chamber 3.
3. Open main drain valve B and all drawoff valves and vents at low points throughout the system; close them when water ceases to flow.
4. Open auxiliary drain E and drain remaining water; close when water ceases to flow.
5. Remove cover of dry valve.
6. Carefully clean water seat 5, and water clapper 1.
7. Place water clapper 1 on its seat and replace cover of dry valve.
8. If the valve is equipped with a priming connection, add priming water until water flows out of auxiliary drain E. Close auxiliary drain E.
9. Pump air into the valve to about 15 psi (103 kPa)(1.03b) by opening air supply valve F; close when finished.
10. Remove cover G over the latching mechanism and close the auxiliary valve 9 by securing latching lever 8 to latching lever 7. Replace cover G.

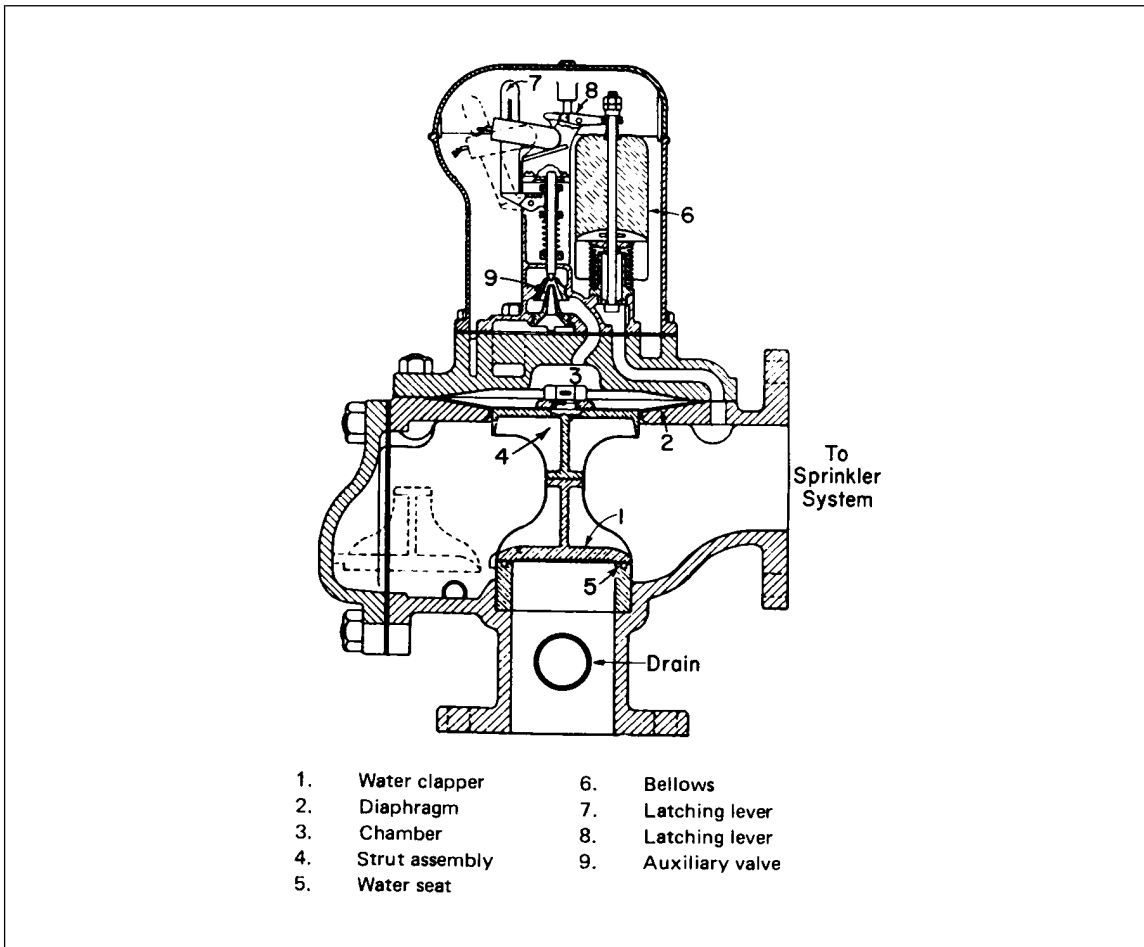

Fig. 38. Grinnell dry-pipe valve Model A.

11. Open valve D.
12. **Open wide the main control valve.**
13. Make sure no leakage occurs at drip valve C.
14. Test the water supply by opening main drain valve B.

GRINNELL DRY-PIPE VALVE

MODEL A 2-INCH (51-MM)*, 1934 TO 1976
MODEL A-2 2-INCH (51-MM), 1976 TO DATE

Grinnell Fire Protection Systems Co., Providence, R. I.

DESCRIPTION

The Grinnell Model A and A-2 valves are similar. Both are differential angle valves (Fig. 41). The principal components are cover 1 and the center valve and diaphragm assembly. The average differential is 6 psi (41 kPa) water pressure to 1 psi (6.9 kPa) air pressure. The center valve and diaphragm assembly consists of air and water clapper 4, rubber facing 6, and spindle 7.

When system air pressure is reduced sufficiently, the differential is destroyed, allowing water pressure to force the center valve assembly up where it is locked in a full open position by engagement of latch washer 2 against the grooves on spindle 7.

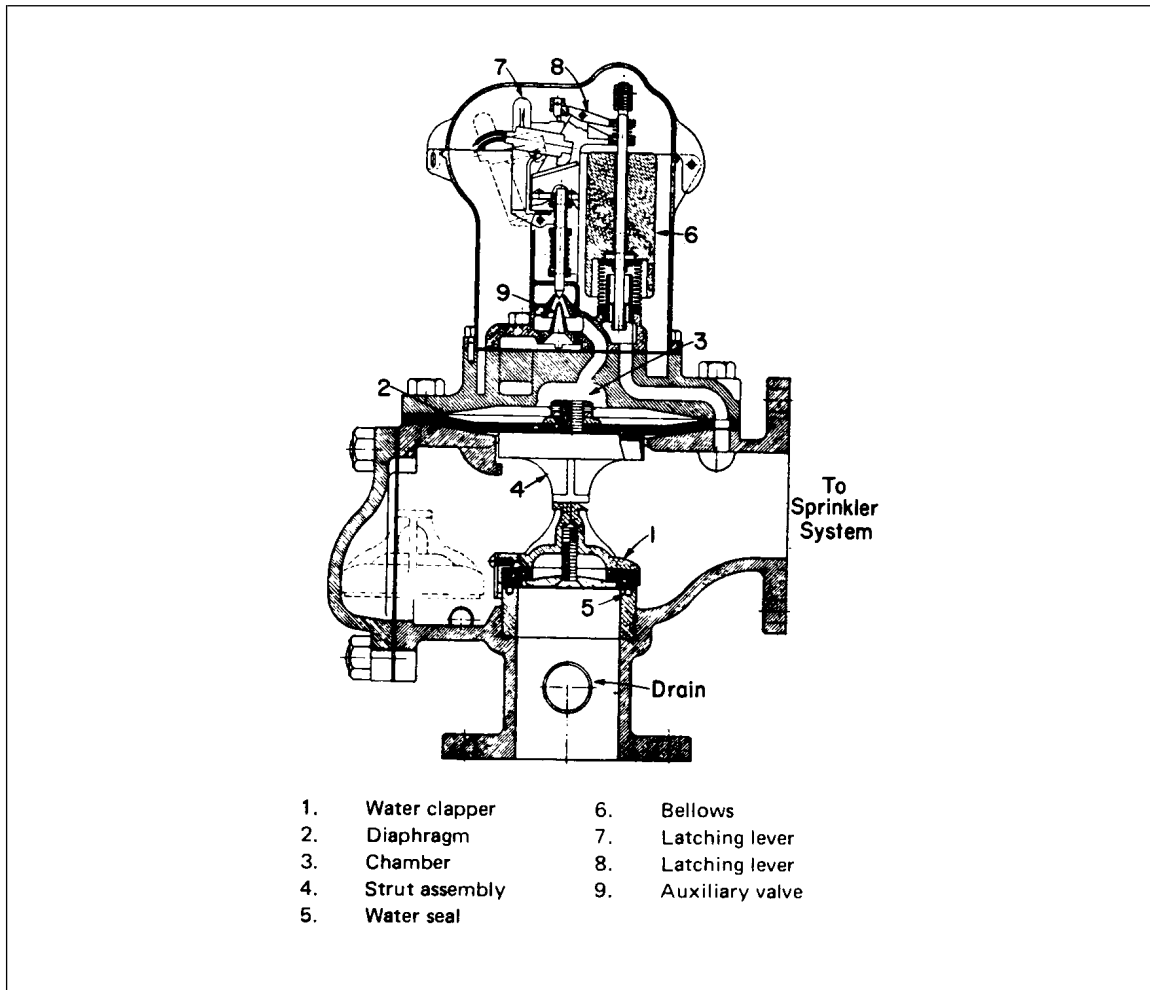

Fig. 39. Grinnell dry-pipe valve Model A-2.

SETTING

1. Close the main control valve supplying water to the system.
 2. Open main drain valve B (Fig. 42) and all drawoff valves and vents at low points throughout the system; close them when water ceases to flow.
 3. Remove cover 1 by unscrewing it.
 4. Invert and slightly shake the cover so that air and water clapper 4 may be removed from latch washer 2.
 5. Clean air and water clapper 4, air seat 5, water seat 3, and rubber facing 6.
- (Formerly known as Cold Weather Valve)
6. Carefully place air and water clapper 4 in the valve on its seat.
 7. Prime the valve by pouring about 1 pint of water over the clapper. If valve is properly seated, there will be no leakage at ball drip C.
 8. Replace cover 1.
 9. Pump air into the system.

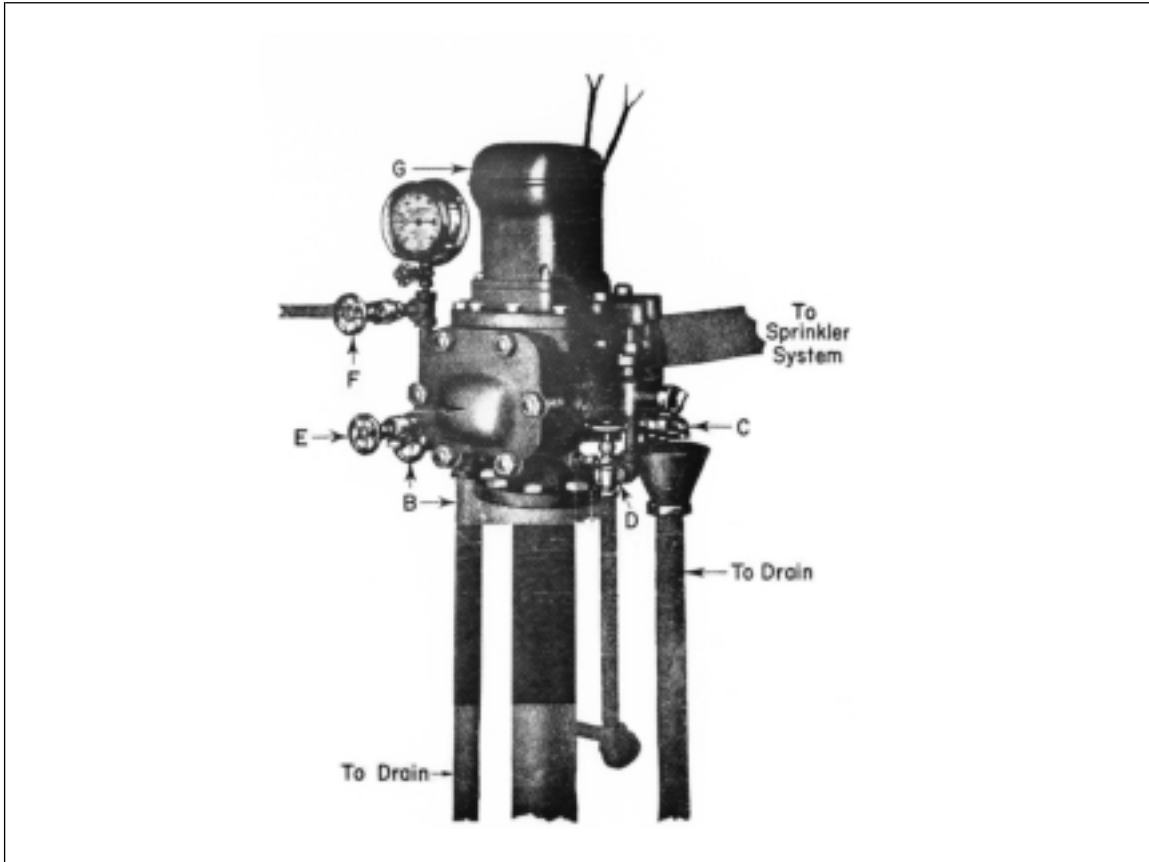

Fig. 40. Grinnell Model A and A-2 dry-pipe valve trim.

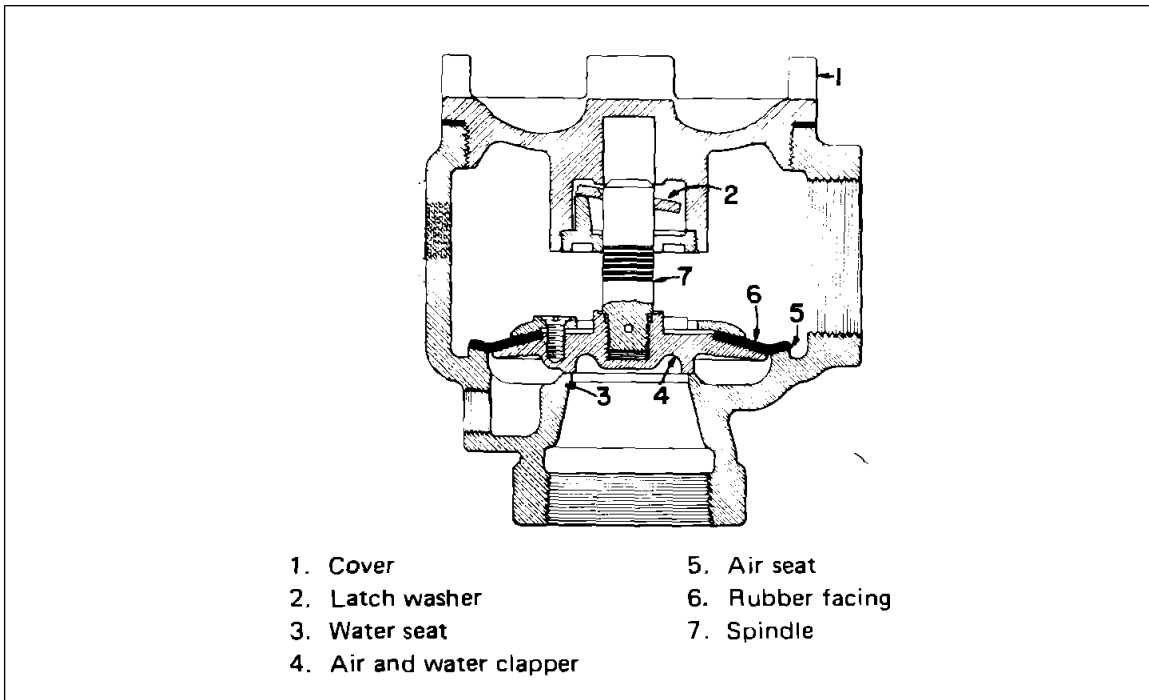

Fig. 41. Grinnell Model A dry-pipe valve, internal view.

2-10R Dry-Pipe, Deluge, Preaction Valves & Accessories

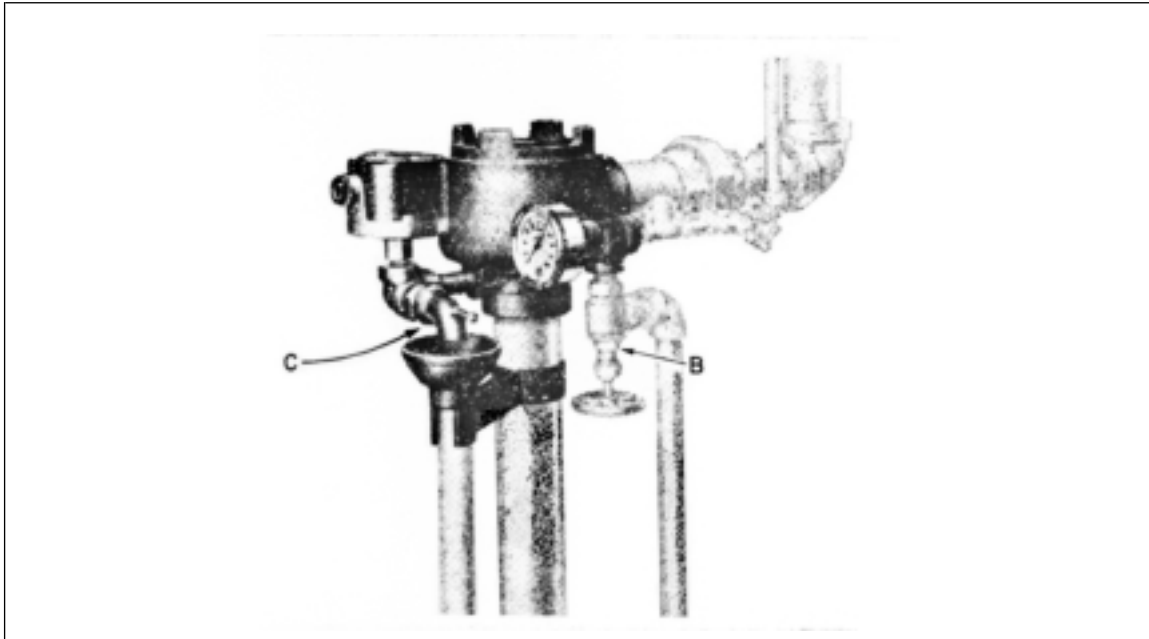

Fig. 42. Grinnell Model A Dry-pipe valve trim.

Table 9

Highest Service Water Pressure or Fire Pump Pressure			Air Pressure					
			Not Less Than			Not More Than		
psi	(kPa)	(bars)	psi	(kPa)	(bars)	psi	(kPa)	(bars)
50	(345)	(3.45)	15	(103)	(1.03)	25	(172)	(1.72)
75	(517)	(5.17)	20	(138)	(1.38)	30	(207)	(2.07)
100	(689)	(6.89)	25	(172)	(1.72)	35	(241)	(2.41)
125	(862)	(8.62)	30	(207)	(2.07)	45	(310)	(3.10)
150	(1034)	(10.3)	35	(241)	(2.41)	50	(345)	(3.45)

10. **Slowly open wide the main control valve.**
11. Make sure no leakage occurs at drip valve C.
12. Test the water supply by opening main drain valve B.

2.12 Grinnell Model D

Grinnell Dry-Pipe Valve Model D

6 - INCH-1919 TO 1925
3 - INCH-1919 TO 1954*

Grinnell Fire Protection Systems Co., Providence, R.I.

DESCRIPTION

The Grinnell Model D dry-pipe valve (Fig. 43.) is of the differential type. The water clapper is attached to the underside of the air clapper by a ball and socket joint. Both clappers are carried to the open position by center valve arm (8). The waterway at the inlet end is 6 inches and tapers to a 5-inch water seat. The outlet end is 6 inch straight.

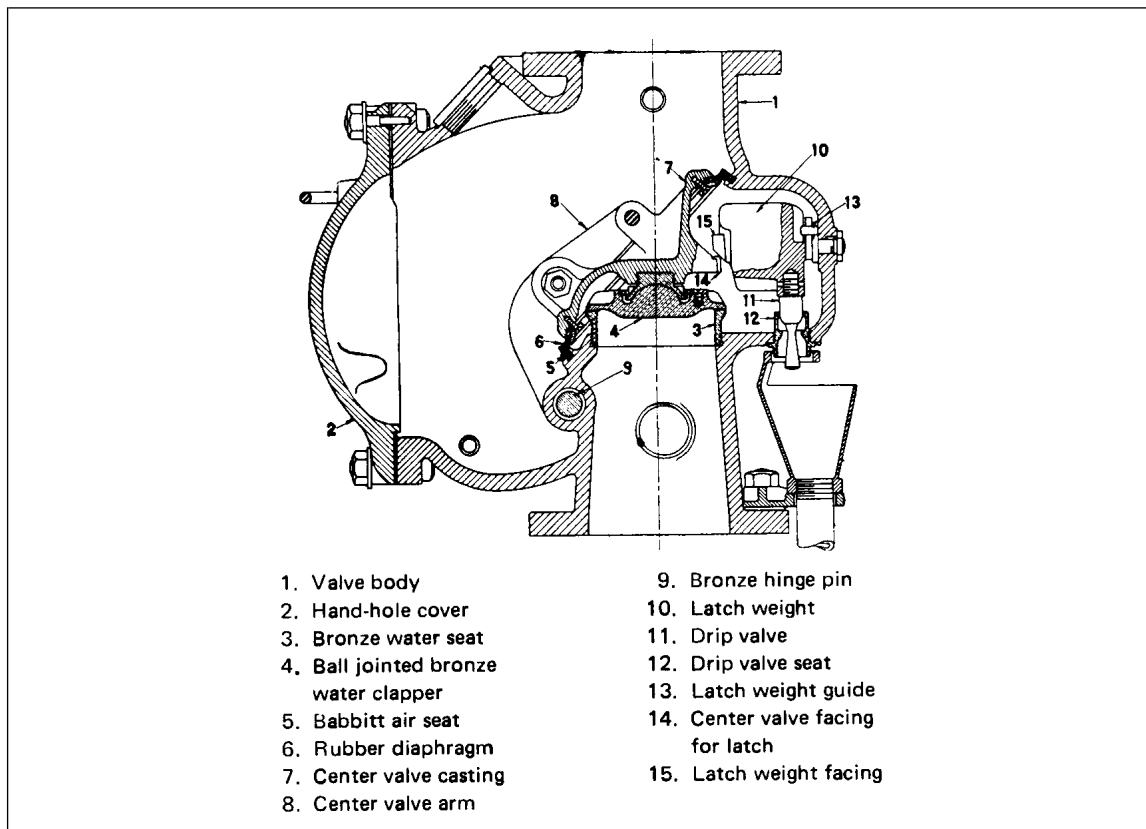

Fig. 43. Model D, internal view.

Latch weight (10) with its facing (15) is provided to prevent the valve reseating after tripping. When the dry-pipe valve trips, center valve facing (14) moves up and past latch weight facing (15). Latch weight (10) is then free to drop, closing the drip valve. Facing (15) is so located that, should the center valve casting (7) attempt to reseat, center valve facing (14) will bear on top of facing (15) and prevent reseating.

*Model C 5-inch and 6-inch (1916-1919) was similar to Model D, except that the waterway was straight instead of tapered.

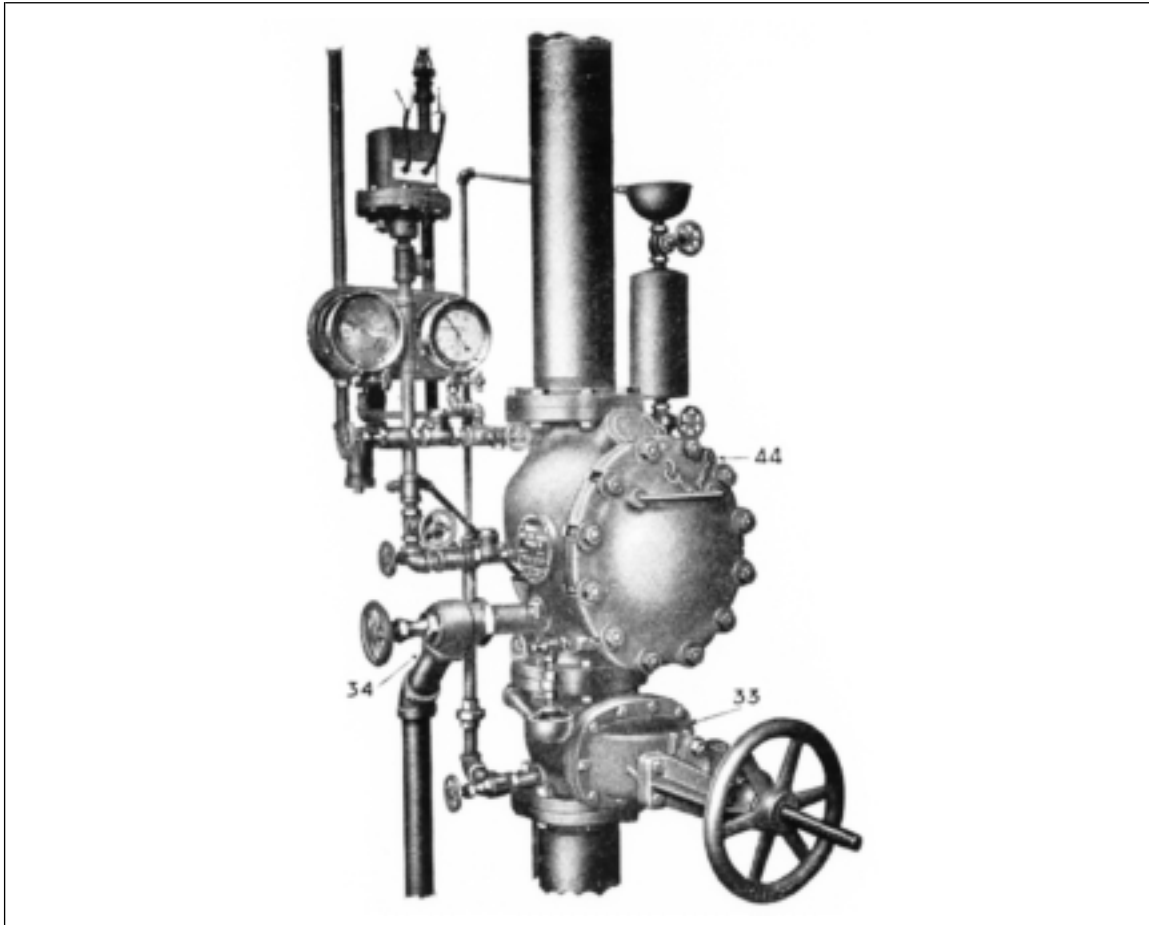

Fig. 44. Model D, external view.

SETTING

To set the Model D dry-pipe valve (Fig. 43 and 44), close the main control valve (33). Drain the system and leave drain valve (34) open. Remove the hand-hole cover (2). Thoroughly clean seat ring (3), ball jointed bronze water clapper (4), babbitt air seat (5), and rubber diaphragm (6). Push the air clapper slowly from the hand-hole opening until it drops onto the latch weight facing (15). Raise latch weight (10) by means of the rod which extends through drip valve seat (12). This will permit the air and water clappers to seat. Bolt hand-hole cover (2) in place. Admit priming water through the priming chamber to the level of test valve (44). Pump up the required air pressure in the system. While the air is being pumped up, make sure that weight (10) is free to move by lifting up on the rod which extends through drip valve (12).

Open the main control valve (33) until water starts to flow from drain valve (34). Close drain valve (34) slowly and observe that no leakage appears at drip valve seat (12) and that latch weight (10) is free to move by lifting on rod. If there is no leakage the valve seats (3) and (5) are tight. Open the main control valve (33) to the wide open position.

Make a drain test through drain valve (34). After determining that the main control valve (33) is wide open, remove red tag and apply seal. Record data regarding valve tripping on the "Tripping Record of Dry-Pipe Valve" placard.

SPECIAL INSTRUCTIONS AND PRECAUTIONS

Failures of Model D valves which have occurred were attributed to binding of latch weight (10). The valves can be depended upon for reliable service if properly maintained. It is essential that the latch weight be lifted at weekly inspections by plant maintenance men. Follow instructions carefully when resetting the valves. See that latch weight (10) is free when setting is completed.

GRINNELL DRY-PIPE VALVES MODELS E, E-2, F-300
MODEL E, 6 IN.-1925 TO 1927
MODEL E-2, 4 IN.-1931 TO 1971
MODEL E-2, 6 IN.-1927 TO 1971
MODEL F-300*, 4 IN.-1971 TO DATE
MODEL F-300*, 6 IN.-1971 TO DATE
Grinnell Fire Protection Systems Co., Providence, R.I.

DESCRIPTION

The Grinnell Models E, E-2, and F-300 dry-pipe valves are differential dry valves of similar construction. The Model E (Fig. 45) has air clapper (7) made of cast iron with its arm bolted to it. Water clapper (4) is hinged to its arm and the clapper arm (8) is hinged at the side of the body as in the Models E-2 and F-300.

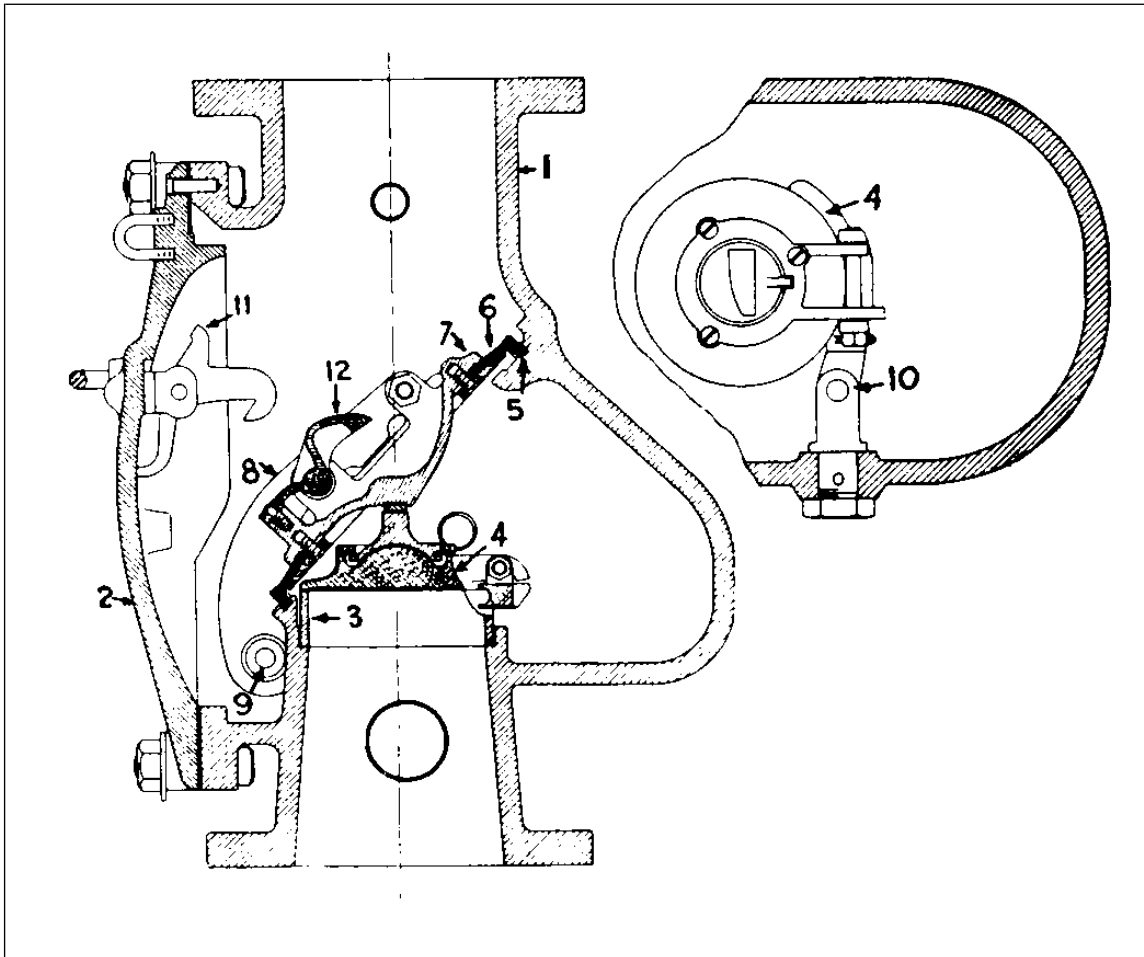

Fig. 45. Model E, internal view.

The Models E-2 and F-300 valves (Fig. 46) which are the later design have air clapper (7) made entirely of bronze with the clapper arm cast integral with it. Water clapper (4) is cast integral with its arm and is hinged at the side of the body. The newer Model F-300 differs from the Model E-2 in that air clapper (7) has a U-shaped rubber facing, replacing the former flat rubber facing which was held by a retaining washer and screws. Water clapper (4) is redesigned for ease of manufacture. However, these new features do not change the operating characteristics of the valve.

OPERATION (Fig. 45)

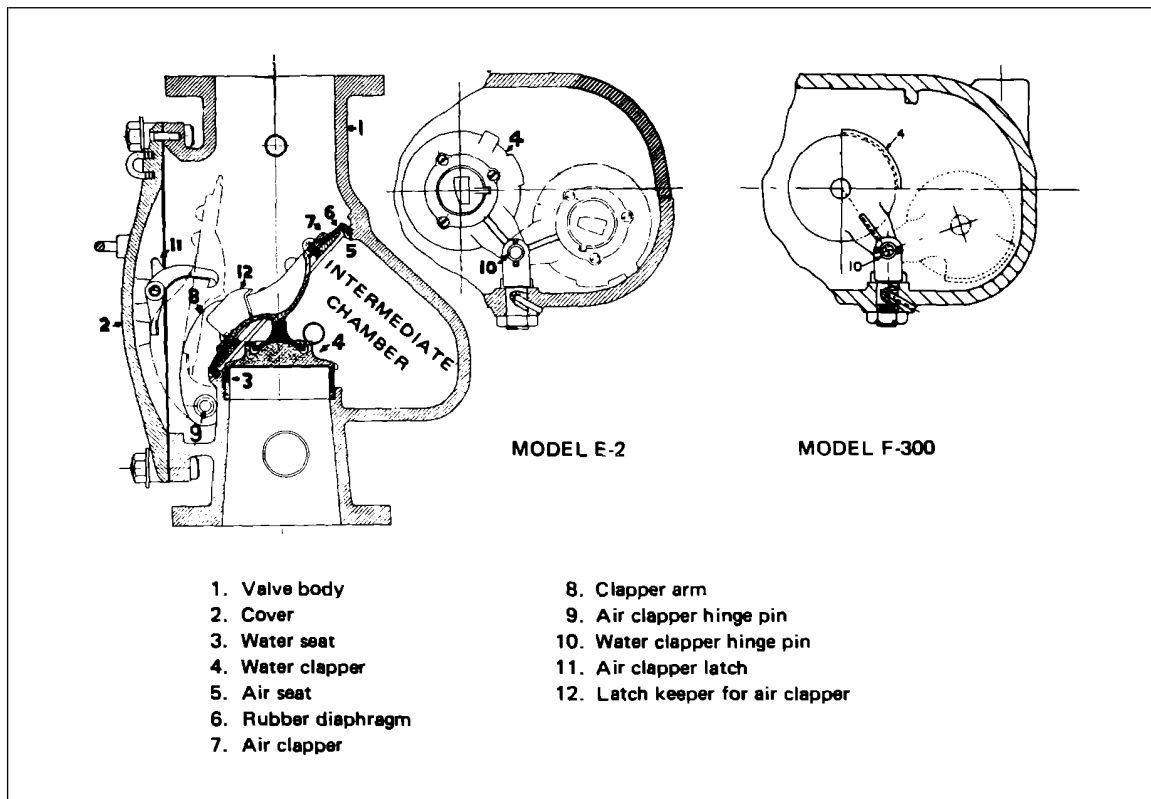

Fig. 46. Models E-2 and F-300, internal view.

When the dry-pipe valve is in normal set position, air clapper (7) rests on air seat (5). System air pressure applied to air clapper (7) resists water pressure on water clapper (5) thus holding the valve in the closed position.

When system air pressure is reduced sufficiently, water pressure under water seat (3) causes water clapper (4) to move slightly on water clapper hinge pin (10). This movement slightly raises air clapper (7) from air seat (5) enabling the flow of water to throw water clapper (4) from water seat (3). Water then fills the intermediate chamber causing air clapper (7) to rotate on air clapper hinge pin (9) until air clapper latch (11) engages latch keeper (12).

SETTINGS (Fig. 46 and 47)

1. Close main control valve (A).
2. Open main drain valve (B) and all drawoff valves and vents at low points throughout the system, closing them when water ceases to flow.
3. Open valve (F) to drain the body of dry valve; close when finished.
4. Remove hand-hole cover (2). If water has been trapped (as explained in **SPECIAL INSTRUCTIONS**) above the air clapper (7), remove bottom bolts on cover (2) to let water drain from valve. Carefully clean air seat (5), rubber diaphragm (6), water seat (3), and water clapper (4).
5. Lift water clapper (4) to clean water seat (3) and pull it forward until water clapper (4) seats centrally on water seat (3). Place air clapper (7) on its seat.
6. Replace and tighten cover.
7. Open upper priming valve (C), lower priming valve (D), and test valve (E). Fill the dry valve through priming cup (G) until water flows into drip cup (H) through the pipe from test valve (E).
8. Close lower priming valve (D) and test valve (E). Fill priming chamber (I). Then close upper priming valve (C).

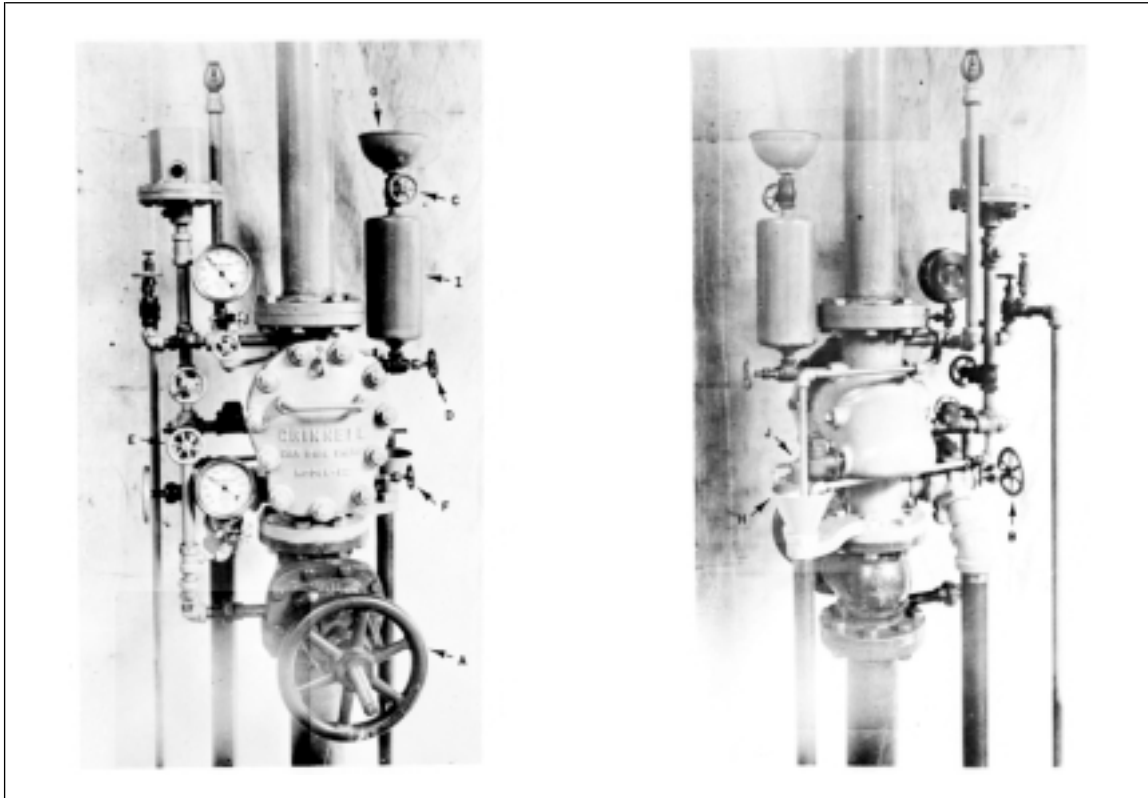

Fig. 47. Dry-pipe valve as installed with trim.

9. Pump air into the system to required pressure.
10. Open main control valve (A) until water starts to flow from main drain valve (B). Close main drain valve (B), making sure that ball drip (J) is free to move and that no leakage occurs.
11. Open main control valve (A).
12. Test water supply by opening main drain valve (B).

*Model F-300 duplicates Model E-3.

SPECIAL INSTRUCTIONS

If the air clapper of Models E, E-2, and F-300 fails to latch, the valve cannot “water column” unless water clapper (4) also returns to its seat. Failure to latch may indicate obstruction or throttled water supply preventing drainage through the 2-in. drain.

2.13 Grinnell Models F302 and F3021

Grinnell Dry-Pipe Valves

Models F302 and F3021

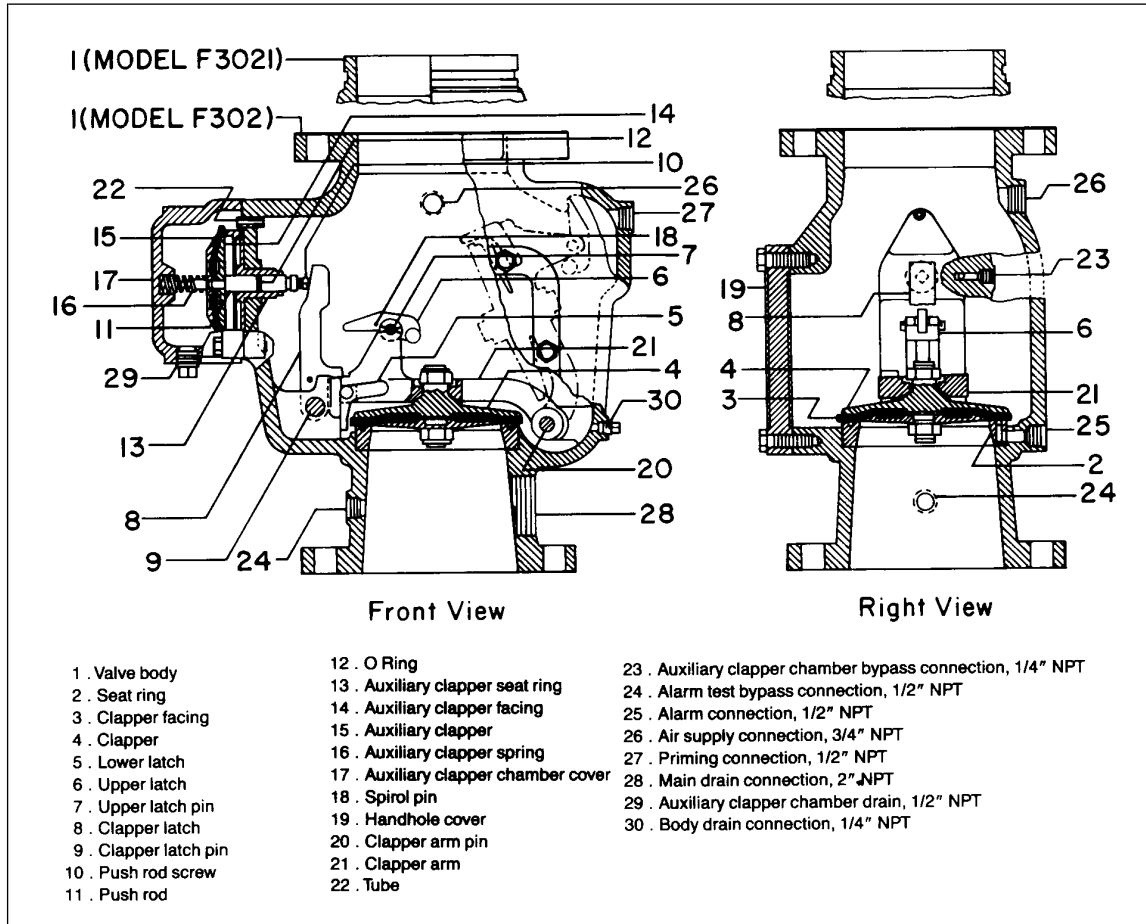

Fig. 48. Model F302 and Model F3021 dry-pipe valves.

DESCRIPTION

The Grinnell Model F302 and the Model F3021 dry-pipe valves use a combination of air pressure and mechanical leverage to control water flow. The valves are of identical design, varying only by their arrangement for outlet connection. (The F302 is flanged, whereas the F3021 is grooved.) Both are manufactured in 4 and 6 in. (100 and 150 mm) sizes.

The majority (about 75%) of the force needed to hold the clapper closed is provided through the clapper latch by air pressure in the auxiliary clapper chamber. The length of each "arm" of the clapper latch and the placement of the clapper latch pin create a mechanical advantage of about 6 to 1. The remainder of the needed force is provided by system air pressure acting directly on the clapper.

OPERATION

(Numbered references are to Fig. 48 unless otherwise specified.)

As air pressure is decreased, the force exerted by the auxiliary clapper (15) (through the latch pin (9)) and the direct force on the clapper facing (3) are reduced until the clapper (4) begins to lift. Water then enters a groove in the waterway seat ring (2) and proceeds through the alarm port (25) into a portion of the valve trim. The trim carries the water to the automatic drain valve (11, Fig. 49), the connection for alarm devices (Fig. 49), and on to the auxiliary chamber through the feedback connection (23). This flow causes the

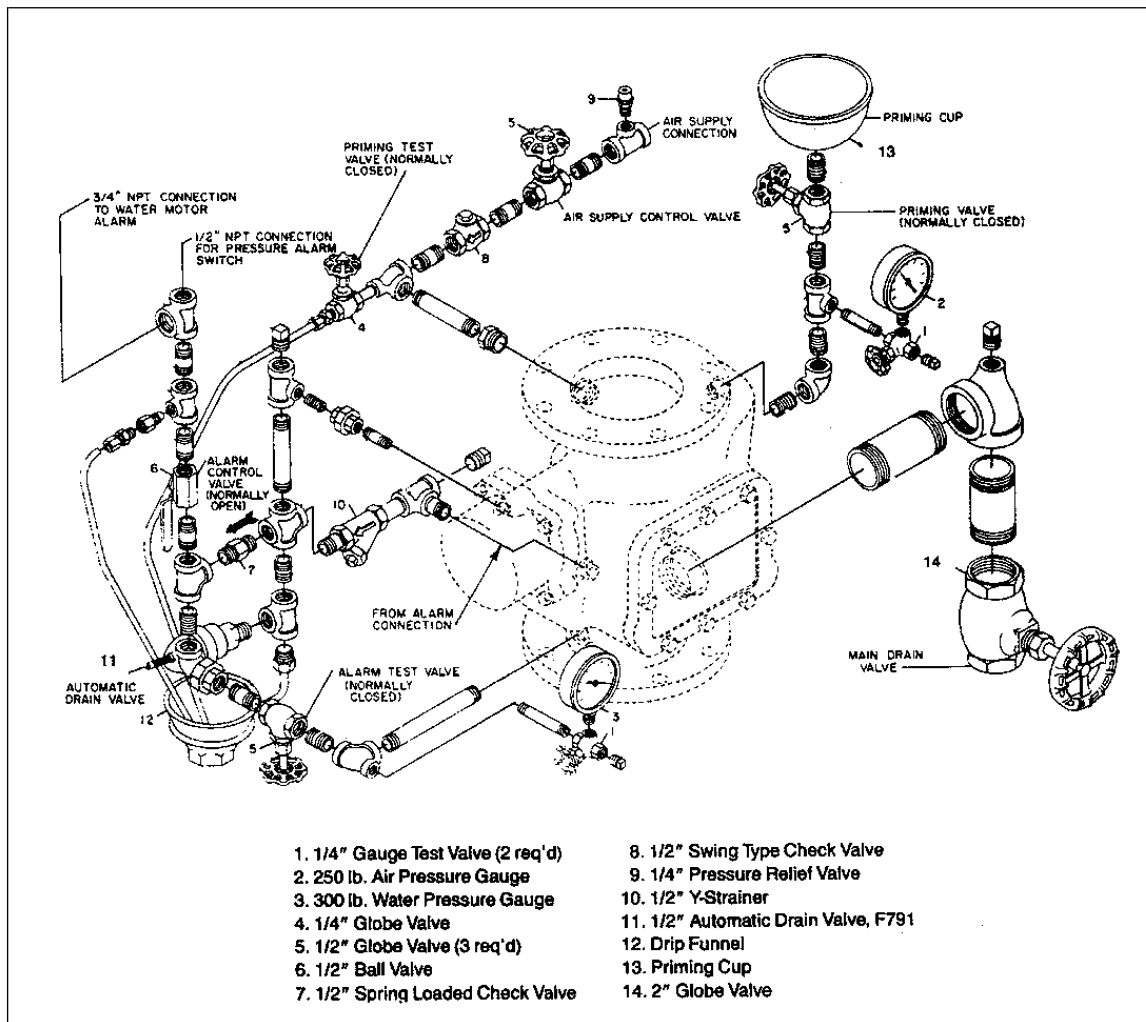

Fig. 49. Basic trimmings for Model F302 and Model F3021 dry-pipe valves.

differential pressure across the auxiliary clapper (15) to reach equilibrium. The force from the push rod (11) to the latch (8) is eliminated and the clapper is thereby allowed to raise to its fully open (latched) position.

RESETTING

The valve may be reset as follows:

- 1a. Close the main control valve and the air supply control valves (4,5, Fig. 49).
 - b. If an accelerator is provided, close the control valve between the accelerator and the system piping.
2. Open the main drain valve (14, Fig. 49), the inspector's test connection, and all auxiliary drains. Close the auxiliary drains and the inspector's test connection when water ceases to flow, but leave the main drain valve open.
3. Remove the strainer screen (10, Fig. 49). Clean and reinstall it.
4. Remove the handhold cover (19) and check the clapper arm (21) and latches (5, 6, 8) for freedom of movement. Clean the valve interior and check the clapper facing (3) and seat ring (2) for damage and replace them if warranted.

5. Remove the auxiliary clapper chamber cover (17). (The auxiliary clapper spring (16) will come out as well.) Remove the auxiliary clapper assembly (11, 12, 13, 14, 15, 16) and check to see that the auxiliary clapper rod (11) is still well lubricated. Its O-ring (12) should also be coated with lubricant. Check the tube (22) passageway for obstructions.
6. Unlatch the clapper arm assembly (21) from its operated position. Pivot the latches (6, 8) to allow the clapper (4) to be reseated.
7. Uniformly cup the auxiliary clapper facing (14) towards the push rod (11) and reinstall the auxiliary clapper assembly.
8. Rotate the clapper latch (8) until it engages the nose of the clapper arm (21).
9. While holding the latch (8) and the arm (21) in place, replace the auxiliary clapper spring (16) and the auxiliary chamber cover (17).
10. Release the latch (8) and replace the handhold cover (19).
11. Open the priming valve (5, Fig. 49) and the priming test valve (4, Fig. 49).
12. Prime by slowly pouring water into the priming cup (13, Fig. 49) until water discharges from the drip funnel (12, Fig. 49). Then close the priming valve and priming test valve (Fig. 49).
13. Pressurize the system to about 20 psi (138 kPa). During this time, hold the plunger of the automatic drain valve (11, Fig. 49) depressed. (Water and air may discharge.) The plunger may be released if water and/or air do not discharge or if discharge ceases before 4 psi (28 kPa) is reached. Otherwise, hold the plunger until 20 psi (138 kPa) is reached.
14. After reaching 20 psi (138 kPa), drain any trapped water by opening all auxiliary drains. Close the valves once discharge ceases.
15. Fully pressurize the system in accordance with Table 1.
16. After reaching the required pressure, close the two control valves (4, 5, Fig. 49) in the air supply line. Note: If an air maintenance device is provided, leave the valves open.
17. Close the main drain valve (14, Fig. 49).
18. Slowly open the main control valve (not shown).
19.
 - a. Depress the automatic drain valve plunger (11, Fig. 49). If there is no discharge, the clapper facings are properly seated.
 - b. If water discharges when the plunger is depressed, the clapper is not properly seated and the problem must be corrected. Close the main control valve (not shown), open the main drain valve (14, Fig. 2), close the air supply control valve(s), open the inspector's test connection (not shown), and repeat the resetting procedure.
20. Reset the accelerator if one is provided.
21. Open the alarm control valve (6, Fig. 49).

Table 10. Required Air Pressure

<i>Maximum Water Supply Pressure psi (kPa)</i>	<i>Maximum Recommended Air Pressure psi (kPa)</i>
25 (172)	15 (103)
50 (345)	20 (138)
75 (517)	25 (172)
100 (690)	30 (207)
125 (862)	35 (241)
150 (1034)	40 (276)
175 (1207)	45 (310)

RECOMMENDATIONS

1. The valves discussed above, as well as all other dry-pipe valves, need periodic maintenance. See Data Sheet 2-81 for recommended procedures.

2.14 Grinnell Straightway Model B

Grinnell Dry-Pipe Valve - Straightway Model B

**4-, 5-, 6-INCH
1910 TO 1916**

Made by the General Fire Extinguisher Co., Providence, R. I., for the Grinnell Co., Providence, R. I. Model A (1907-1910) was similar to Model B.

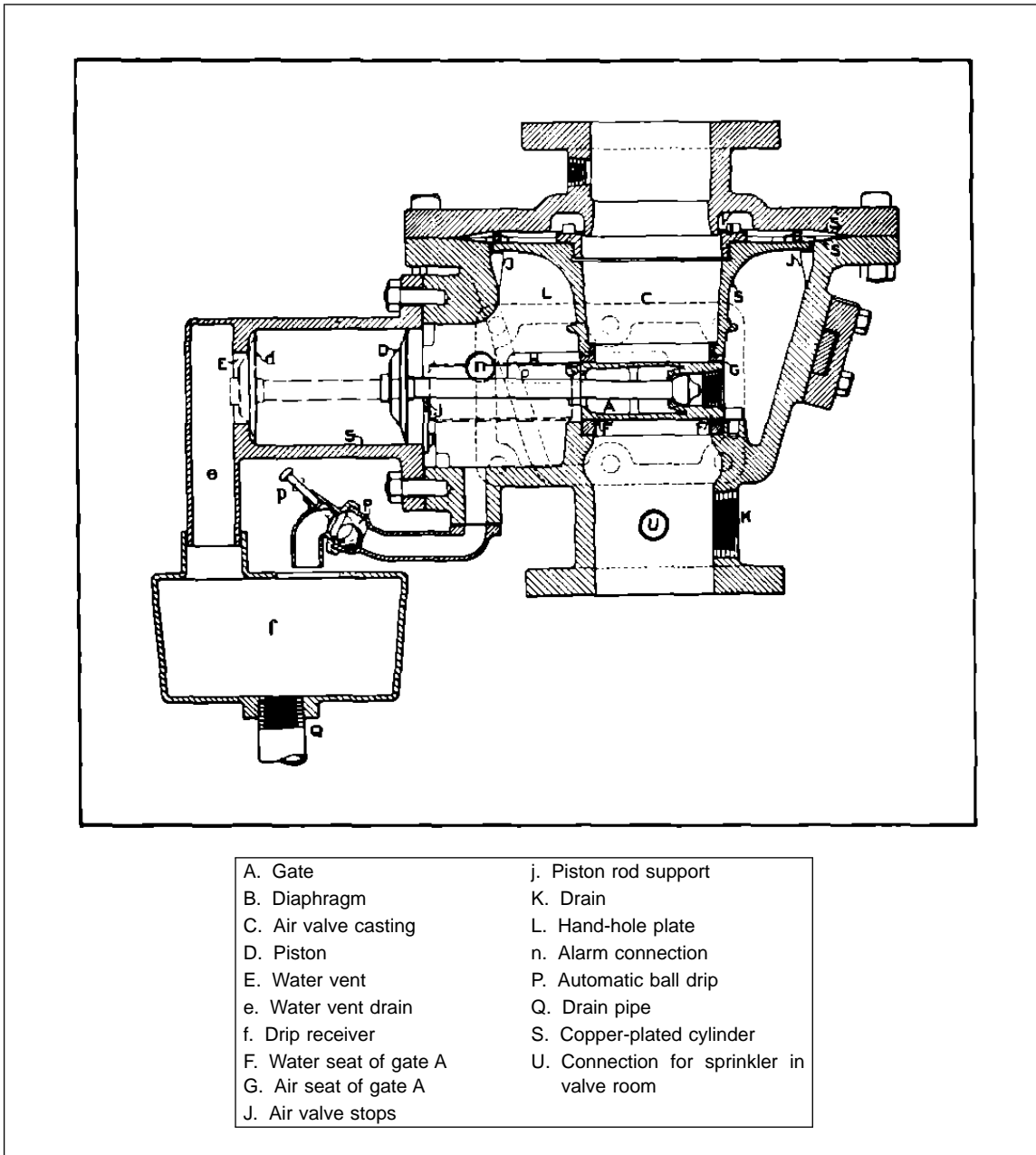

Fig. 50. Straightway Model B - Internal View.

The Grinnell Straightway Model B dry-pipe valve is a differential hydraulically operated gate valve and has a straight 6-inch waterway. The gate of the valve is clamped between the air and water seats by a coneshaped casting attached to a diaphragm.

To set the valve close the main gate valve, and attach red tag, drain the system, remove the hand-hole plate L (Fig. 51) and clean seats F and G and both faces of the gate A. (Fig. 50). Raise casting C and slide gate A on its seats until it comes into position against its stop. Close valve T (Fig. 51) and prime the valve through the funnel until water appears at Z. Then close valves X and Z. Open valve V and pump up the necessary air pressure. Close drain valve K and open the main gate valve. If no water is noted leaking past the seats of gate A, bolt hand-hole plate L in place. Make a drain test through the drain valve K. After determining that the main control valve is wide open, remove red tag and apply seal. Record data regarding valve tripping on the "Tripping Record of Dry-Pipe Valve" placard.

DIRECTIONS FOR TESTING

Note that the main gate valve is open. Then open test cock Z (Fig. 51) and if any water escapes draw it off. Then tightly close Z. Open water test T to make sure there is an ample supply of priming water. Then close T. If air escapes, the valve should be primed by using the reservoir, until water appears at test cock Z.

Hand-hole plate L should be removed occasionally to determine if the intermediate chamber is clean and free from deposits or other obstructions. Then shut and bolt plate L in place. Ball drip valve P should be tested to make sure that it is free to move. Test the water supply by opening 2-inch drain K.

SPECIAL INSTRUCTIONS AND PRECAUTIONS

Cover must be bolted tightly when set dry. Special caution is needed on this point, as the cover is usually left open while setting to observe for leaks at either seat.

In the Model B valve the copper-plated cylinder sometimes blisters, and may prevent complete travel of the piston D. In this case much water may be discharged through water vent E. New cylinders are not available. The valve may be retained in service temporarily, until a new approved valve can be secured, by scraping out the old cylinder and greasing it with petroleum jelly.

2.15 Grinaw Model A

Grunaw Dry-Pipe Valve

MODEL A

6 IN., 1957 TO DATE

4 IN., 1971 TO DATE

3 IN., 1972 TO DATE

Grunaw Sprinkler Corp., Norwich, Conn.

DESCRIPTION

The Grunaw Model A dry-pipe valve (formerly known as the C.S.B. Model A dry-pipe valve) is a differential valve having a single clapper with rubber facing for both air and water seat rings. (See Fig. 52).

The intermediate chamber is formed by the cavity between the water and air seat rings and the clapper, when it is in a set position. This chamber is open to atmosphere through a connection to the automatic velocity drain valve.

OPERATION

When the dry-pipe valve is in normal set position, the clapper (5, in Fig. 52) rests on the water and air seat ring. Priming water on top of the clapper helps to seal the air seat and also to preserve the rubber facing. System air pressure acting on the top of the clapper acts against water pressure beneath the clapper to hold clapper on its seat rings at a ratio of 1 psi air pressure to 5.0 to 6.5 psi water pressure. The loss of system air pressure, through operation of one or more sprinklers, destroys the differential and water pressure acting under the clapper forces the clapper open.

SETTING THE VALVE

1. Close the main gate valve controlling the water supply to the dry-pipe valve.

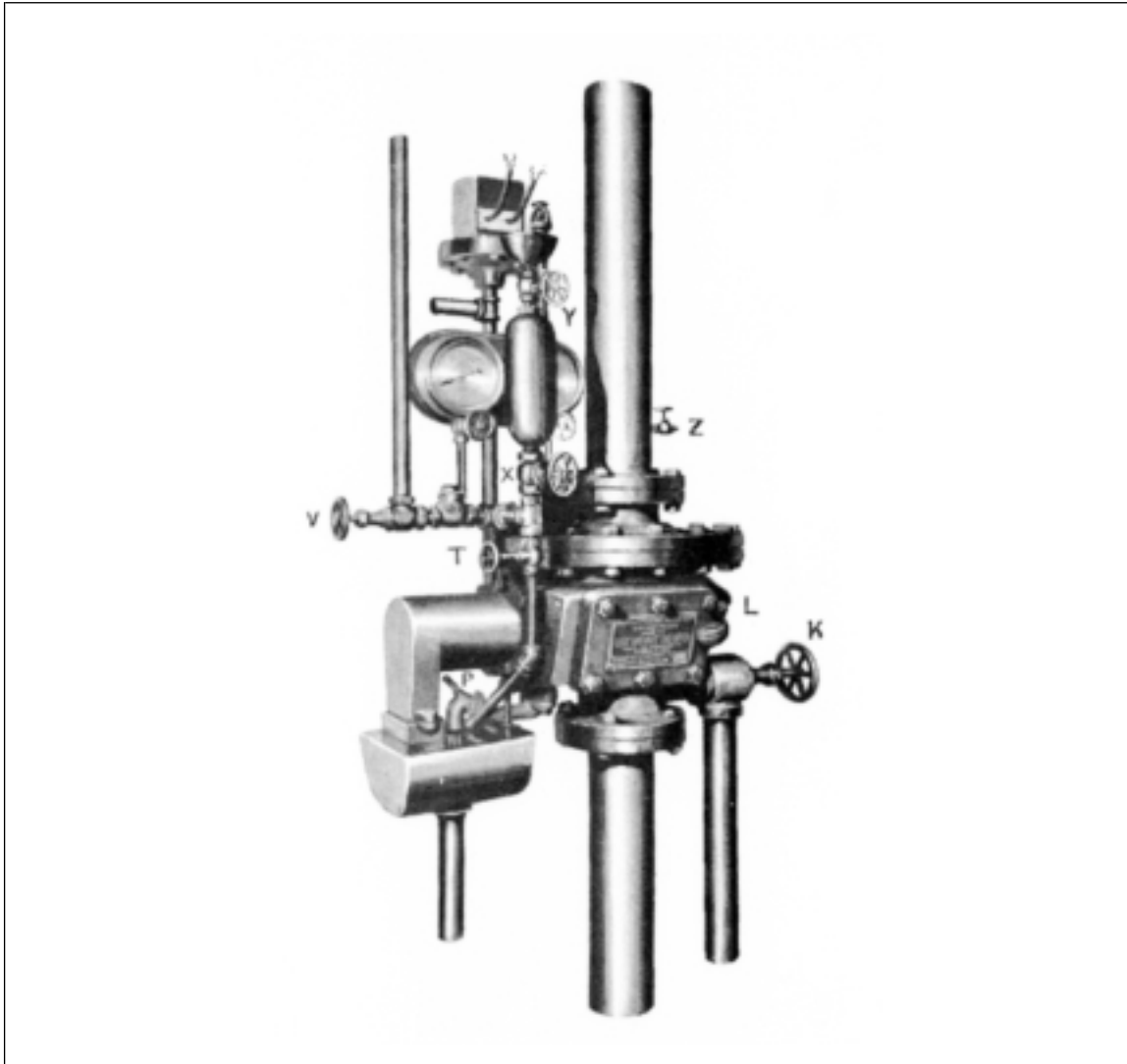
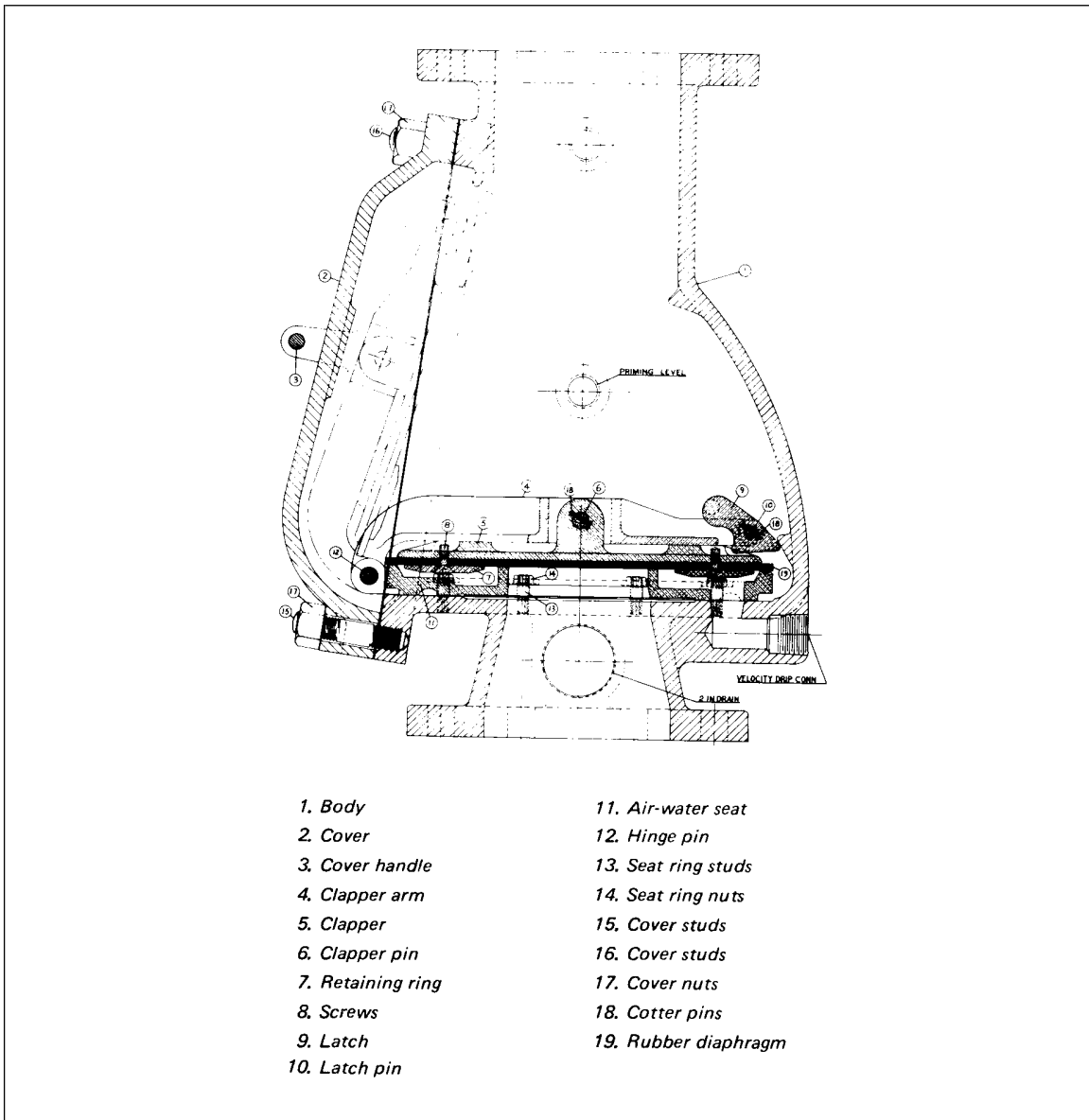

Fig. 51. Straightway Model B - External View.

2. Open main 2-in. drain valve (Fig. 53) and drain system. Open all drain valves and vents at low points throughout the system, and close them when water flow has stopped.
3. Remove hand hole cover (2, in Fig. 52) and rotate clapper assembly outward. Clean carefully the water and air seat surfaces (11, in Fig. 52) and clean all surfaces of rubber diaphragm (19, in Fig. 52) with a clean cloth or waste. Do not apply grease, compound, or oily materials to rubber facing.
4. Raise clapper latch (9, in Fig. 52) and swing clapper assembly in and downward to a closed position on its seat.
5. Replace rubber hand hole gasket and hand hole cover (2, in Fig. 52) and tighten bolts and nuts securely.
6. Open valve (F, in Fig. 53) and fill dry-pipe valve with water until water remains in priming cup (G, in Fig. 53). Then open valve (E, in Fig. 53) until water ceases to flow in into drain cup (C, in Fig. 53). Priming water is now at the proper level. Close valve F (in Fig. 53) and valve E (in Fig. 53) tightly.
7. Open air valve (R, in Fig. 53) and permit a few pounds of air pressure to enter the system. This will be indicated on the gage (P, in Fig. 53).
8. Open separately drain valves (see Step 2 above) to force water from low points of the system. Close these valves when dry air appears.



- | | |
|-------------------|----------------------|
| 1. Body | 11. Air-water seat |
| 2. Cover | 12. Hinge pin |
| 3. Cover handle | 13. Seat ring studs |
| 4. Clapper arm | 14. Seat ring nuts |
| 5. Clapper | 15. Cover studs |
| 6. Clapper pin | 16. Cover studs |
| 7. Retaining ring | 17. Cover nuts |
| 8. Screws | 18. Cotter pins |
| 9. Latch | 19. Rubber diaphragm |
| 10. Latch pin | |

Fig. 52. Grunau Model A dry-pipe valve.

9. Open stop cock (K, in Fig. 53) to the wide-open position. This should always remain in the normally open position to permit waterflow to alarms.

10. Open the air valve (R, in Fig. 53) and admit sufficient air pressure into the system to hold dry-pipe valve closed. Air pressure should be maintained within the limits shown in the following table:

Table 11

Maximum water pressure (psi)	Air pressure range (psi)
50	15-25
70	20-30
100	25-35
125	30-45
150	35-50

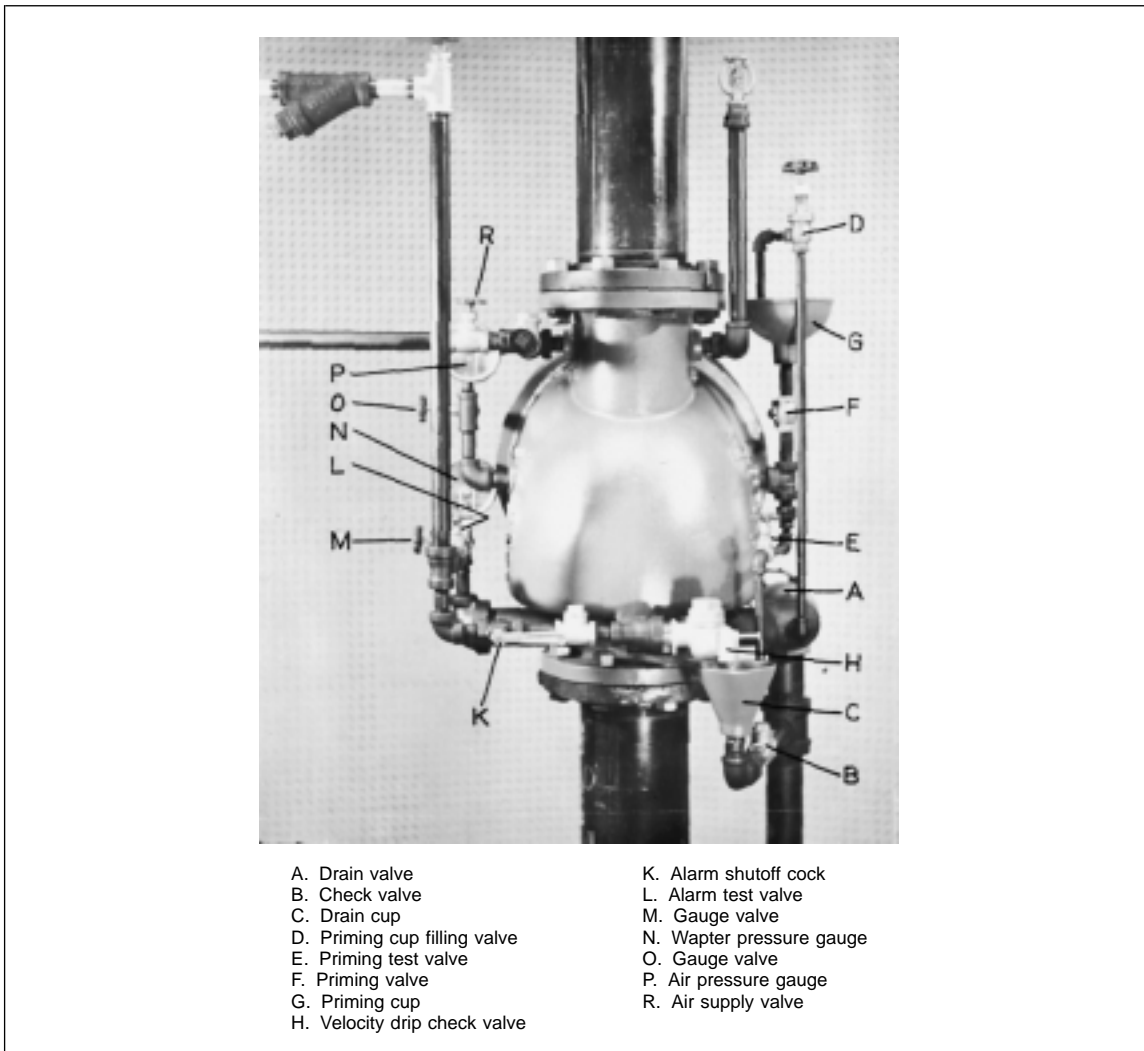

Fig. 53. Grunau dry-pipe valve trim.

After air pressure has remained at the prescribed limit for a few minutes, inspect velocity check valve (H, in Fig. 53). If no leak occurs, air seat is tight. Check to be certain the air valve (R, in Fig. 53) is tightly closed.

11. Open wide drain valve (A, in Fig. 53) and very carefully open the main water supply gate valve slightly. Slowly close the drain valve until water pressure on the gage (N, in Fig. 53) reaches maximum pressure.

Inspect velocity check valve (H, in Fig. 53). If no leak occurs, air and water seats are tight. Open slowly; when fully open, lock main water supply gate valve.

INSPECTION

1. Water Supply

Be certain that all valves controlling water supply to the dry-pipe valve are fully open and locked in this position.

2. Alarm Line

Seal valve (K, in Fig. 53) in the open position.

3. Testing Alarms

Slowly open alarm test valve (L, in Fig. 53) to the wide-open position, permitting water to flow from supply to alarm devices. When alarms have sounded sufficiently, close valve (L, in Fig. 53).

4. System Low Points

The system low points should be checked periodically by opening slightly all drain valves to remove any accumulated water due to condensation. When dry air appears, close these valves.

5. Velocity Check Valve.

Occasionally push the plunger on the velocity check valve (H, in Fig. 53), making sure its clapper is free and no water is accumulated in the intermediate chamber of the valve.

6. Priming Water Level.

Close valve controlling water supply to dry-pipe valve and draw off water pressure from system by opening valve A (Fig. 53). Bleed air pressure from the system to the valve (E, in Fig. 53). Add priming water and reset system according to Steps 6 through 12 in the section **SETTING VALVE**.

2.16 Hodgman Model A

Hodgman Dry-Pipe Valve

MODEL A, 6-INCH (152-MM), 1926 TO 1936

Hodgman Manufacturing Co., Taunton, Mass.

DESCRIPTION

The Hodgman Model A is a differential dry-pipe valve (Fig. 54). Air clapper 1 and water clapper 2 are hinged separately. Drip valve 3 is held open by water clapper 2 being on its seat. When water clapper 2 opens, drip valve 3 is free to close.

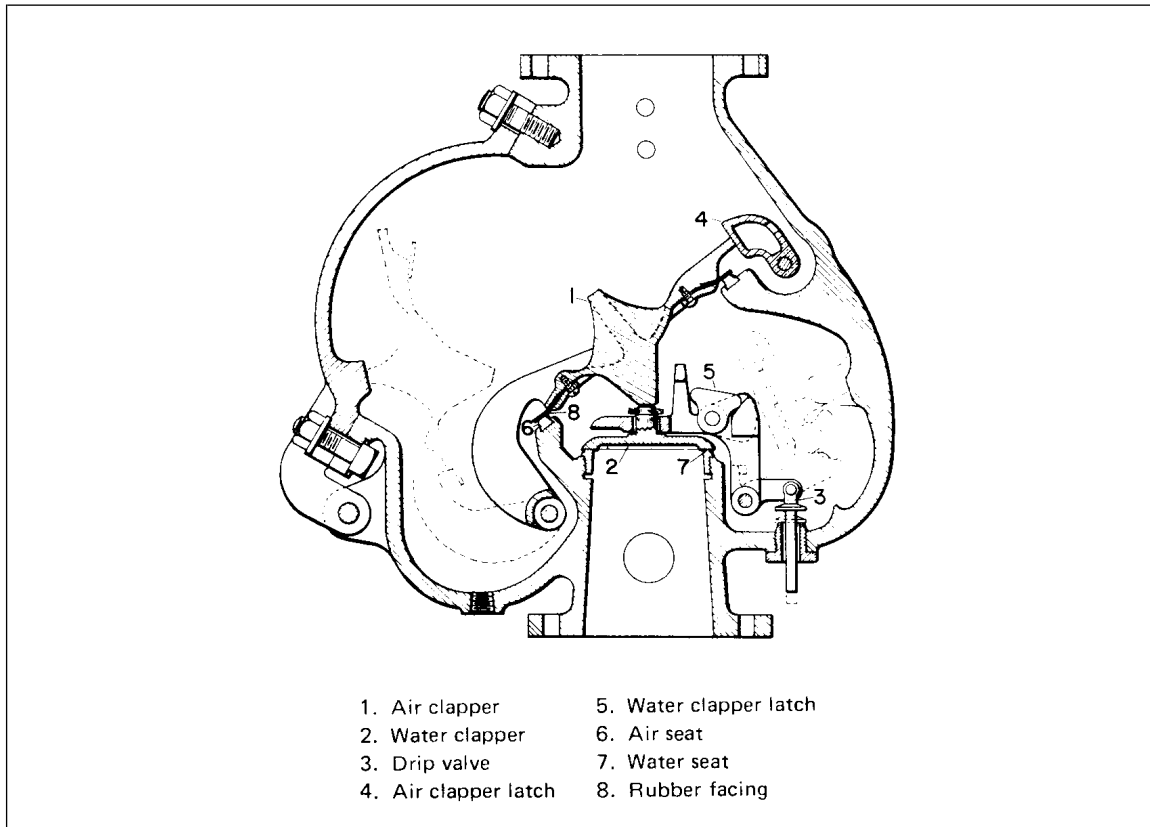

Fig. 54. Hodgman dry-pipe valve, internal view.

When system air pressure is reduced sufficiently, the differential is destroyed and water pressure forces air clapper 1 and water clapper 2 to open. Air clapper 1 is then out of the waterway or held open by air clapper latch 4. Water clapper 2 is also out of the waterway or held open by water clapper latch 5.

SETTING

1. Close the main control valve.
2. Open main drain valve A (Fig. 55) and all drawoff valves and vents at low points throughout the system; close them when water ceases to flow.

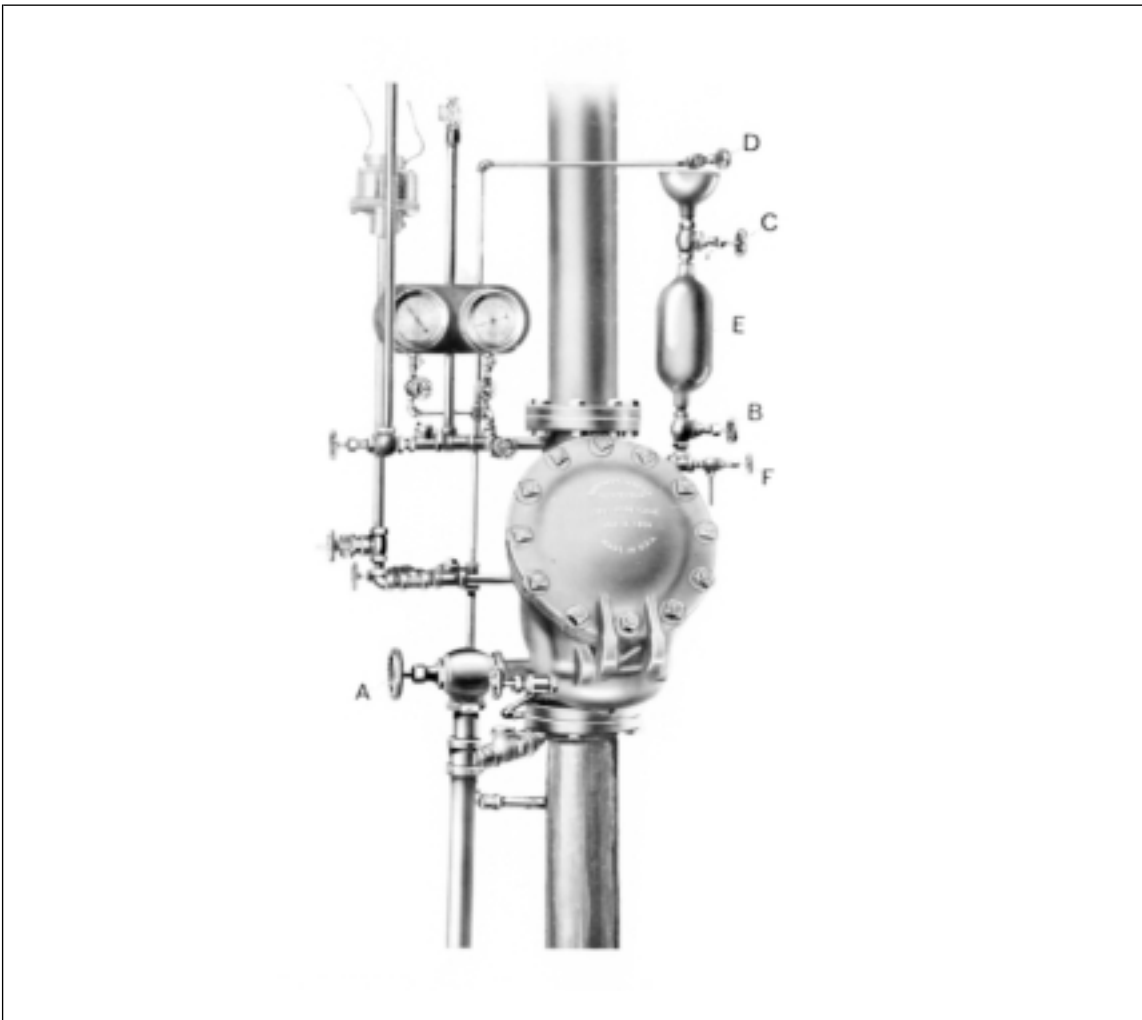

Fig. 55. Hodgman dry-pipe valve trim.

3. Remove cover of dry valve.
4. Carefully clean air seat 6, water seat 7, and rubber facing 8 (Fig. 54).
5. Raise water clapper latch 5 and place water clapper 2 on water seat 7. Lift air clapper latch 4 and place air clapper 1 on air seat 6.
6. Replace and tighten cover.
7. Open lower priming valve B (Fig. 55) and upper priming valve C. Admit priming water by opening priming valve D until water remains in priming chamber E. Close lower priming valve B and upper priming valve C. Open test valve F; close when water ceases to flow.
8. Pump air into the system.

Table 12

Highest Service Water Pressure or Fire Pump Pressure			Air Pressure,					
			Not Less Than			Not More Than		
psi	(kPa)	(bars)	psi	(kPa)	(bars)	psi	(kPa)	(bars)
50	(345)	(3.45)	15	(103)	(1.03)	25	(172)	(1.72)
75	(517)	(5.17)	20	(138)	(1.38)	30	(207)	(2.07)
100	(689)	(6.89)	25	(172)	(1.72)	35	(241)	(2.41)
125	(862)	(8.62)	30	(207)	(2.07)	45	(310)	(3.10)
150	(1034)	(10.34)	35	(241)	(2.41)	50	(345)	(3.45)

9. **Open wide the main control valve.**

10. Make sure no leakage occurs at drip valve 3 (Fig. 54).

11. Test the water supply by opening main drain valve A (Fig. 55).

HODGMAN DRY-PIPE VALVE*
Model A, 3-in. (76-mm) 1929 - 1936
Model B, 3-in. (76-mm) 1936 - 1938

Hodgman Manufacturing Co., Taunton, Mass.

DESCRIPTION

The Hodgman Models A and B are differential dry valves (Fig. 56). Model A has a differential of 3.3 to 1, while the Model B has a differential of 5.2 to 1. This is the only difference between the two valves. In set position notch 3 on the underside of clapper arm 2 fits over a projection or stop on the body between air seat 4 and water seat 5.

When system air pressure is reduced sufficiently, clapper 1 lifts and lead weight 6 causes clapper 1 to rotate counterclockwise. In this position notch 3 and the projection or stop on the body of the valve prevent clapper 1 from reseating.

SETTING

1. Close the main control valve.
2. Open main drain valve A (Fig. 57) and all drawoff valves and vents at low points throughout the system; close them when water ceases to flow.
3. Remove cover of dry valve.
4. Carefully clean air seat 4, water seat 5, and rubber facing 7 (Fig. 56).
5. Rotate clapper 1 clockwise as far as it will go and place it on its seats.
6. Replace and tighten cover.
7. Admit priming water level to the test valve B (Fig. 57).
8. Pump air into the system.

Table 13

Highest Service Water Pressure or Fire Pump Pressure			Air Pressure,					
			Not Less Than			Not More Than		
psi	(kPa)	(bars)	psi	(kPa)	(bars)	psi	(kPa)	(bars)
50	(345)	(3.45)	15	(103)	(1.03)	25	(172)	(1.72)
75	(517)	(5.17)	20	(138)	(1.38)	30	(207)	(2.07)
100	(689)	(6.89)	25	(172)	(1.72)	35	(241)	(2.41)
125	(862)	(8.62)	30	(207)	(2.07)	45	(310)	(3.10)
150	(1034)	(10.34)	35	(241)	(2.41)	50	(345)	(3.45)

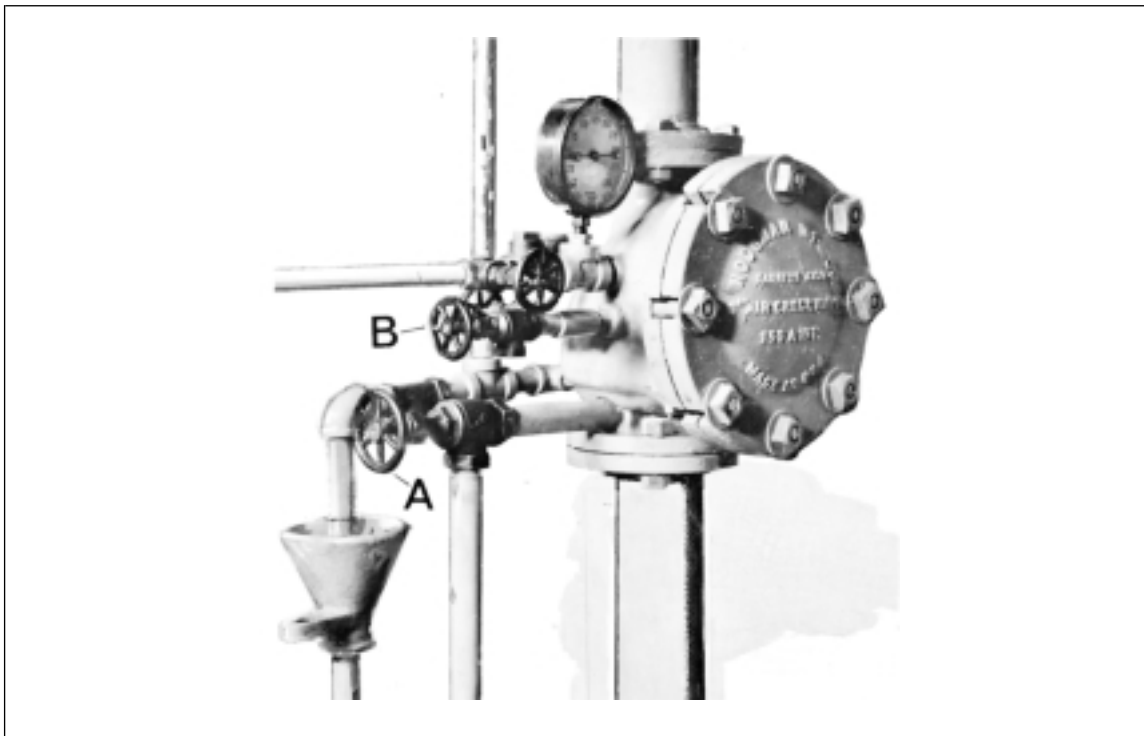

Fig. 57. Hodgman dry-pipe valve trim.

9. Open wide the main control valve.
10. Make sure no leakage occurs at drip valve.
11. Test the water supply by opening main drain valve A (Fig. 57).

2.17 Hodgman Model C

Hodgman Model C Dry-Pipe Valve

3 in. (76 mm) 1938 TO DATE

4 in. (102 mm) 1950 TO DATE

6 in. (152 mm) 1936 TO DATE

Hodgman Mfg. Co., Taunton, Ma.

(The Model C valves installed by Gottschalk Feuerschutz KG, West Germany, have cover plates marked with the Gottschalk name.)

Reference has been made to the Gottschalk Feuerschutz KG, West Germany, sprinkler installation company. Hodgman Model C dry-pipe valves bearing cover plates with the Gottschalk name are listed in the current *Approval Guide*.

The section of the 1959 data sheet covering the International Evans Model 2 and the Manufacturers Model 2 dry-pipe valves has been eliminated. Both valves are obsolete.

DESCRIPTION

The Hodgman Model C is a differential type valve with the air and water seat combined in a single bronze casting. It has a single hinged clapper. The three sizes of valves are similar in design. The 6-in. (152 mm) valve has an average differential of 6.0:1.0, the 4-in. (102 mm) valve (1950-1958) - 5.2:1.0, and the 3-in. (76 mm) valve - 4.6:1.0. The 4-in. (102 mm) valve manufactured since 1958 has a smaller water-seat ring and an average differential of 5.9:1.0.

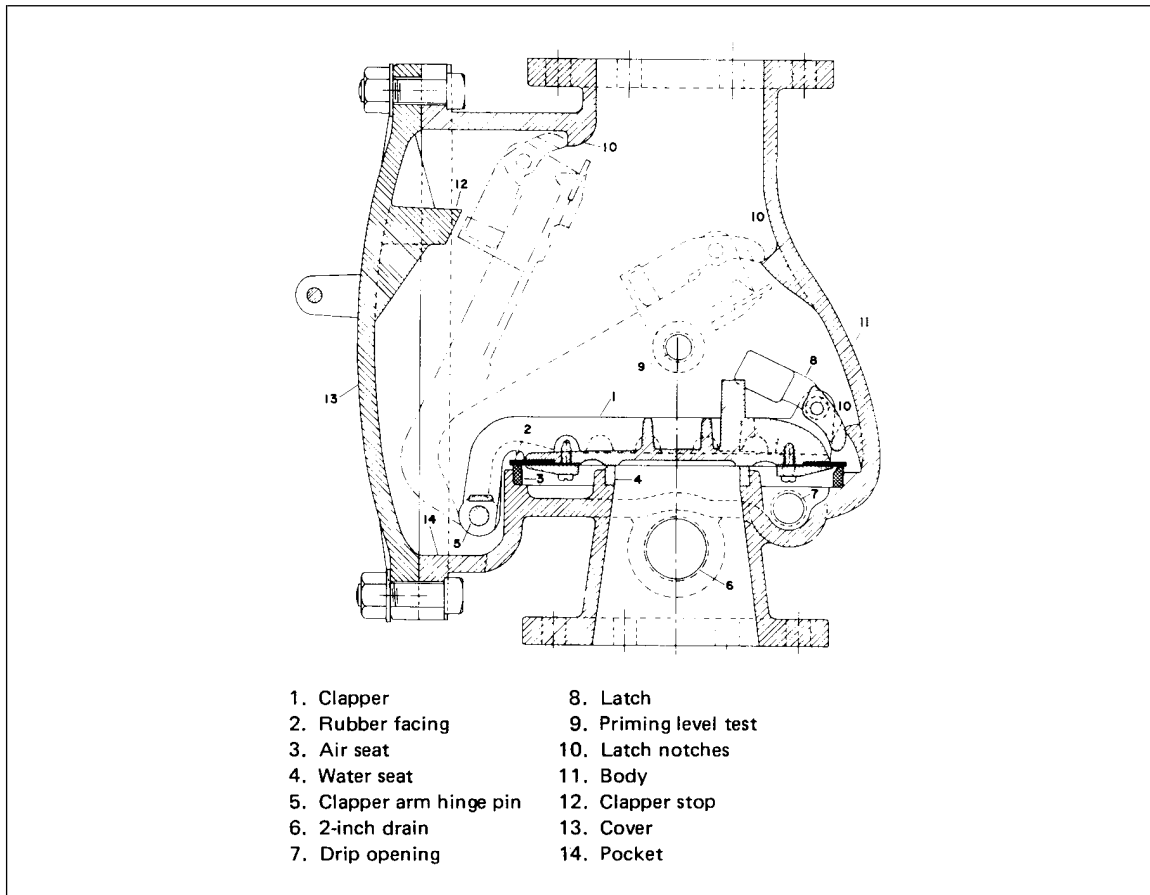

Fig. 58. Hodgman Model C dry-pipe valve.

OPERATION

When the valve is in the set position, clapper 1 rests on water seat 4 and air seat 3. When system air pressure is reduced sufficiently, water pressure forces clapper 1 to swing clear of the waterway. Depending upon the flow of water through the valve, clapper 1 will be held open in one of three positions. This occurs when latch 8 engages one of the latch notches 10 cast into the valve body 11. Sufficient water flow will cause the clapper to strike the clapper stop 12 and engage itself on the third latch notch.

RESETTING

1. Close the main control valve supplying water to the system.
2. Open main drain valve B and all draw-off valves and vents at low points throughout the system. Close them when water ceases to flow.
3. Remove cover 13 and lift clapper 1 onto its third latch notch.
4. Clean water seat 4, air seat 3, and rubber facing 2. Remove any scale on body wall in pocket 14.
5. Unlatch clapper 1 and place it on air seat 3 and water seat 4. Replace and tighten cover 13.
6. Open upper priming valve E and lower priming valve (not shown) located below priming chamber F. Open priming valve C and fill dry valve until water remains in priming chamber F. Open priming level test valve (not shown but located at 9) and allow excess water to leave dry valve. Close priming level test valve and lower priming valve. Fill the priming chamber F with water and close the upper priming valve E when filled.
7. Open air supply valve A and admit sufficient air into the system to hold the clapper closed against maximum water pressure as indicated in Table 14.

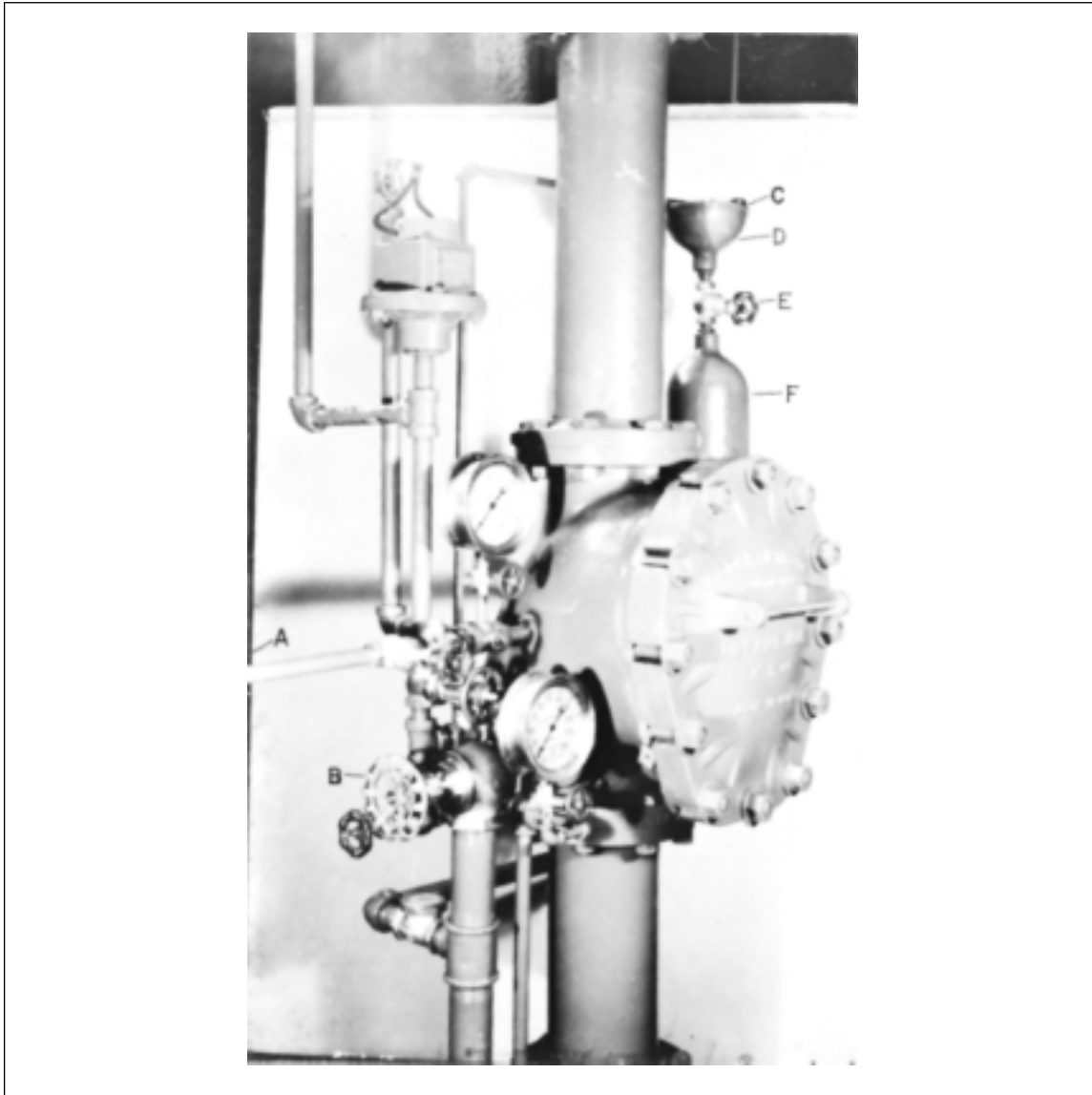

Fig. 59. Trim on Hodgman Model C dry-pipe valve.

Table 14. System Air/Water Pressure

Maximum Water Pressure			Air Pressure					
			Not Less Than			Not More Than		
psi	(kPa)	(bar)	psi	(kPa)	(bar)	psi	(kPa)	(bar)
50	(345)	(3.5)	15	(103)	(1.0)	25	(172)	(1.7)
75	(517)	(5.2)	20	(138)	(1.4)	30	(207)	(2.1)
100	(689)	(6.9)	25	(172)	(1.7)	35	(241)	(2.4)
125	(862)	(8.6)	30	(207)	(2.1)	40	(276)	(2.8)
150	(1034)	(10.3)	35	(241)	(2.4)	45	(310)	(3.1)
175	(1207)	(12.1)	40	(276)	(2.8)	50	(345)	(3.5)

8. When the required air pressure has been established in the system, tightly close air supply valve A. Inspect drip opening 7 for possible priming water leakage past air seat 3.

9. Open the main water control valve slightly and again check drip opening 7 to assure that there is no leakage past water seat 4. If no leakage is observed, air and water seats are tight. Open main control valve wide (slowly, to avoid raising clapper and tripping the valve) and lock valve.
10. Test water supply by opening drain valve B. Dry-pipe valve is now reset and sprinkler system is restored to service.

2.18 KME Model A

K.M.E. Dry-Pipe Valve

MODEL A

4 in. and 6 in. (102 mm and 152 mm) 1919 TO 1923*

Fire Protection Co., Chicago, Illinois**

DESCRIPTION

K.M.E. Model A dry-pipe valve is a differential dry valve (Fig. 60). Air clapper 1 and water clapper 2 are carried to the open position on one short link 3 and two long links 4. In set position water clapper 2 rests on water seat 5, and air clapper 1 rests on air seat 6.

When system air pressure is reduced sufficiently, water pressure will force air clapper 1 and water clapper 2 open.

*Formerly AFM, 1917 to 1919.

**Formerly Kellogg Mackay Equipment Co.

SETTING

1. Close the main control valve supplying water to the system.
2. Open main drain valve (Fig. 61) and all drawoff valves and vents at low points throughout the system; close them when water ceases to flow.
3. Open drain valve F and close when water does not flow.
4. Remove small cover on dry valve and raise air clapper 1 and water clapper 2.
5. Carefully clean air seat 6, water seat 5, and rubber facing 7. Examine short link 3 and long links 4 for any scale or other foreign matter that might prevent the links from operating properly.
6. The clappers should be brought forward until air clapper 1 rests on latch 8. Push upward on drip valve rod 9, which extends through drip valve opening, releasing latch 8 and allowing the clappers to seat.
7. Replace and tighten small cover.
8. Open lower priming valve B and upper priming valve C, allowing water to fill priming chamber D. Close lower priming valve B and upper priming valve C. Open test valve E and let any excess water drain; close when finished.
9. Pump air into the system.

Table 15

Highest Service Water Pressure or Fire Pump Pressure,			Air Pressure					
			Not less than			Not more than		
psi	(kPa)	(bar)	psi	(kPa)	(bar)	psi	(kPa)	(bar)
50	(345)	(3.45)	15	(103)	(1.03)	25	(172)	(1.72)
75	(517)	(5.17)	20	(138)	(1.38)	30	(207)	(2.07)
100	(689)	(6.89)	25	(172)	(1.72)	35	(241)	(2.41)
125	(862)	(8.62)	30	(207)	(2.07)	45	(310)	(3.10)
150	(1034)	(10.34)	35	(241)	(2.41)	50	(345)	(3.45)

10. Make sure drain valve F is closed.
11. Open wide the main control valve.

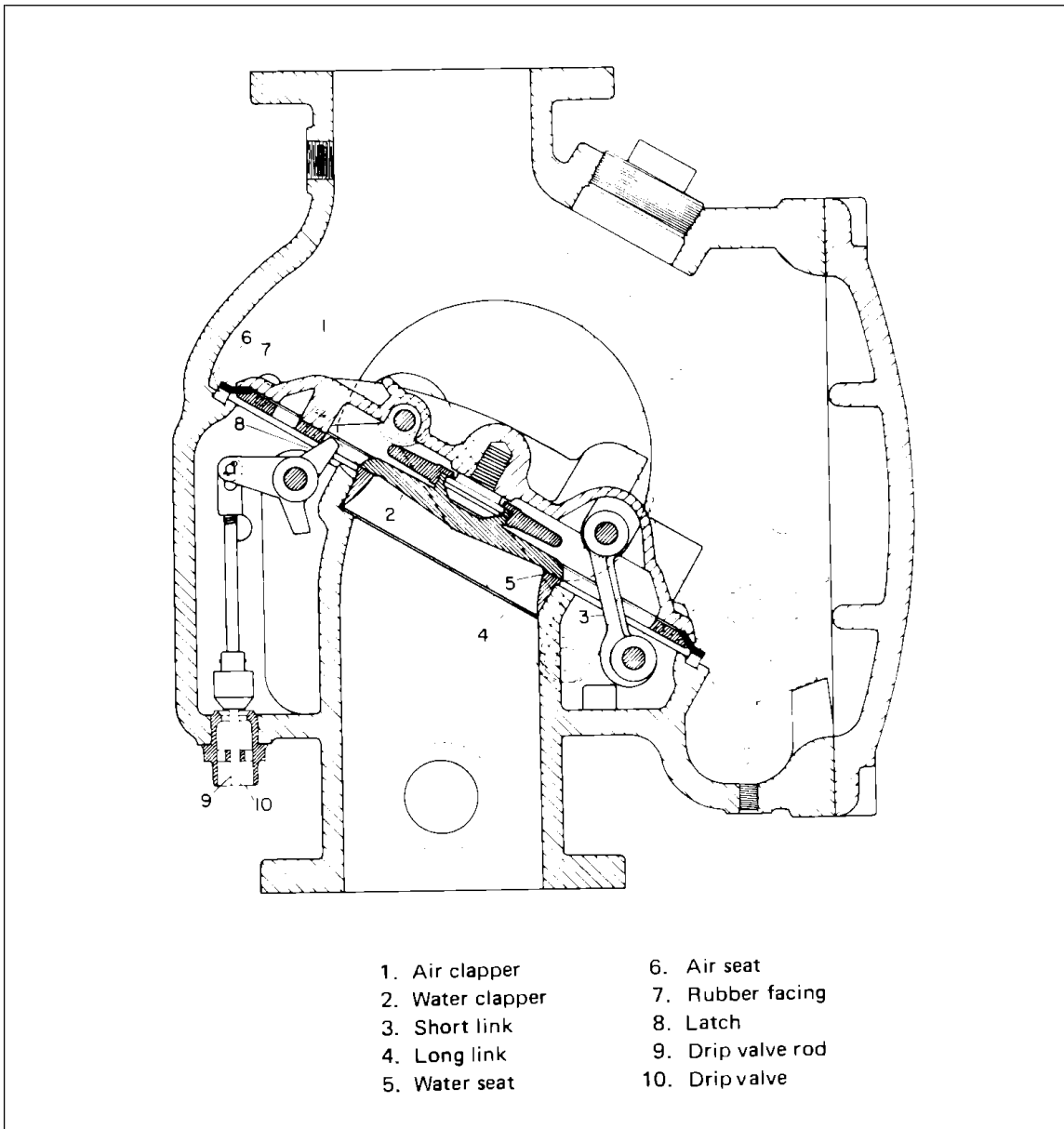

Fig. 60. K.M.E. dry-pipe valve Model A.

12. Make sure no leakage occurs at drip valve G (10, Fig. 1).

13. Test water supply by opening main drain valve A.

**LEWIS DRY-PIPE VALVE
MODEL B, 1926 TO 1954***

Central Automatic Sprinkler Co., Lansdale, Pa.

DESCRIPTION

Lewis Model B dry-pipe valve is a differential dry valve (Fig. 62). Air clapper 1 is hinged to water clapper 2 via link arm 3. In set position water clapper 2 rests on water seat 4 and air clapper 1 rests on air seat 5.

When system air pressure is reduced sufficiently, the differential is destroyed and water pressure will force air clapper 1 and water clapper 2 open.

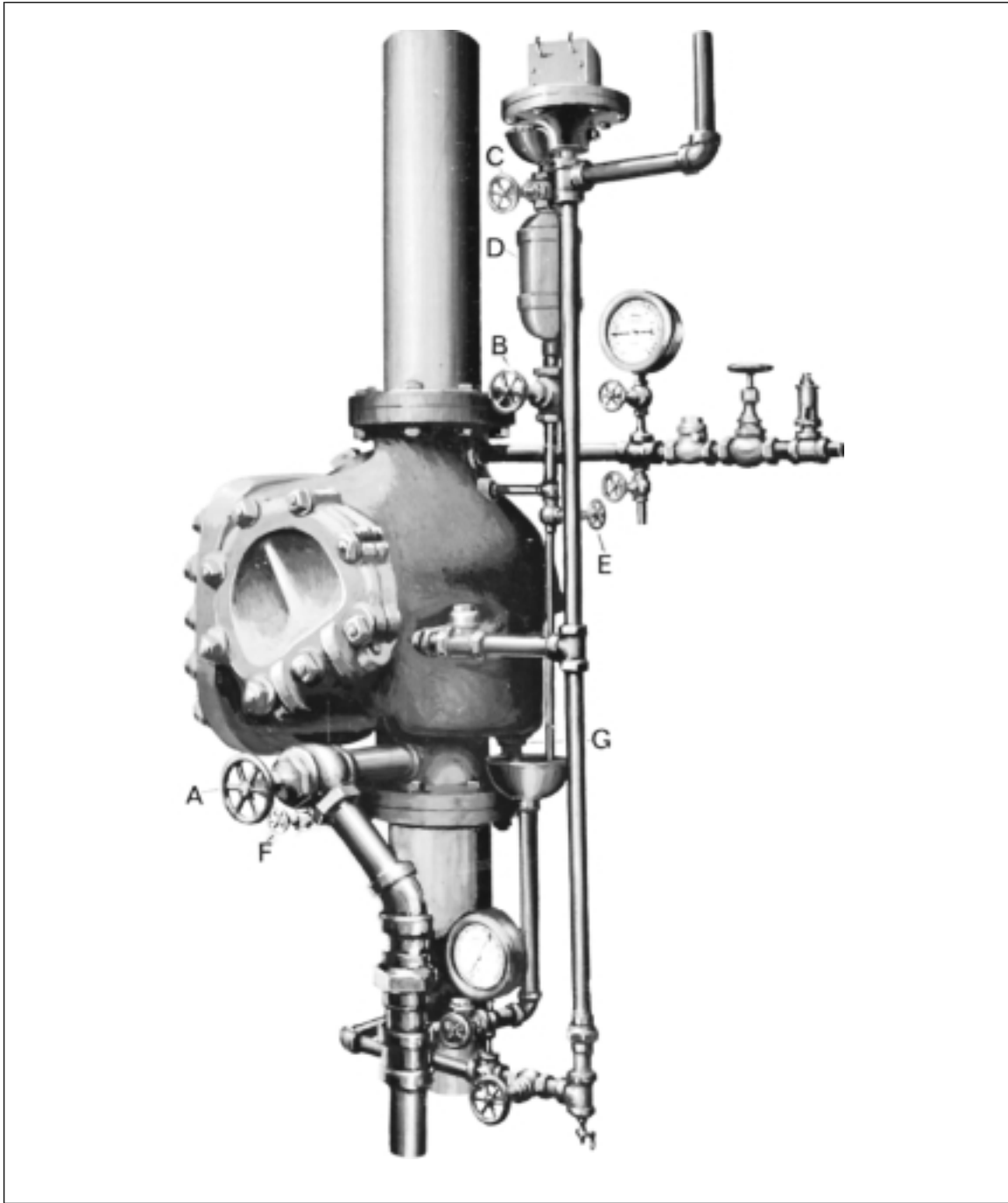

Fig. 61. K.M.E. dry-pipe valve Model A.

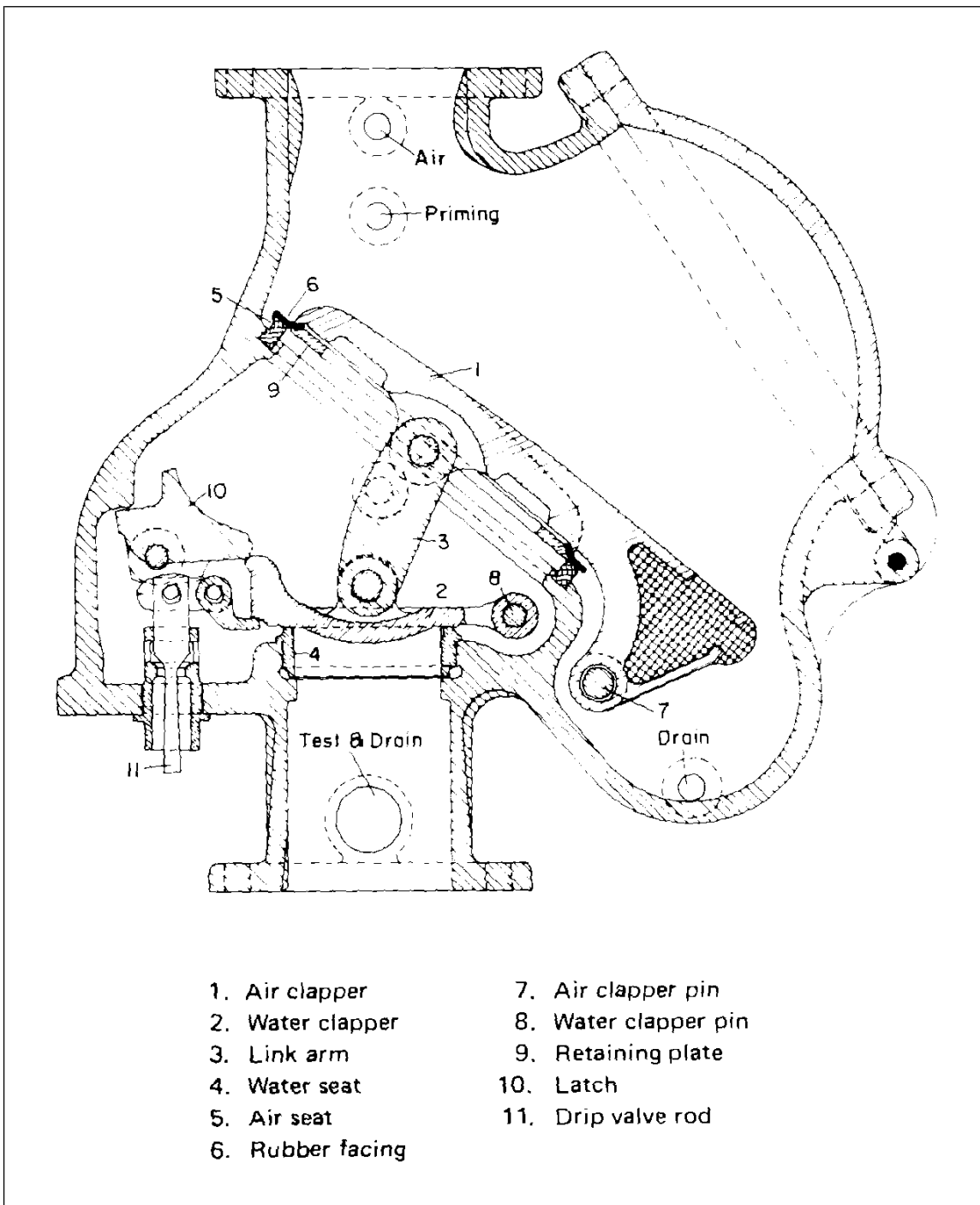

Fig. 62. Lewis dry-pipe valve Model B, internal view.

SETTING

1. Close the main control valve A (Fig. 63) supplying water to the system.

*Model A, 1922 to 1926, is similarly designed.

2. Open main drain valve B and all drawoff valves and vents at low points throughout the system; close them when water ceases to flow. Open drain valve H and close when water has drained.

3. Remove cover of dry valve and open wide air clapper 1 and water clapper 2.

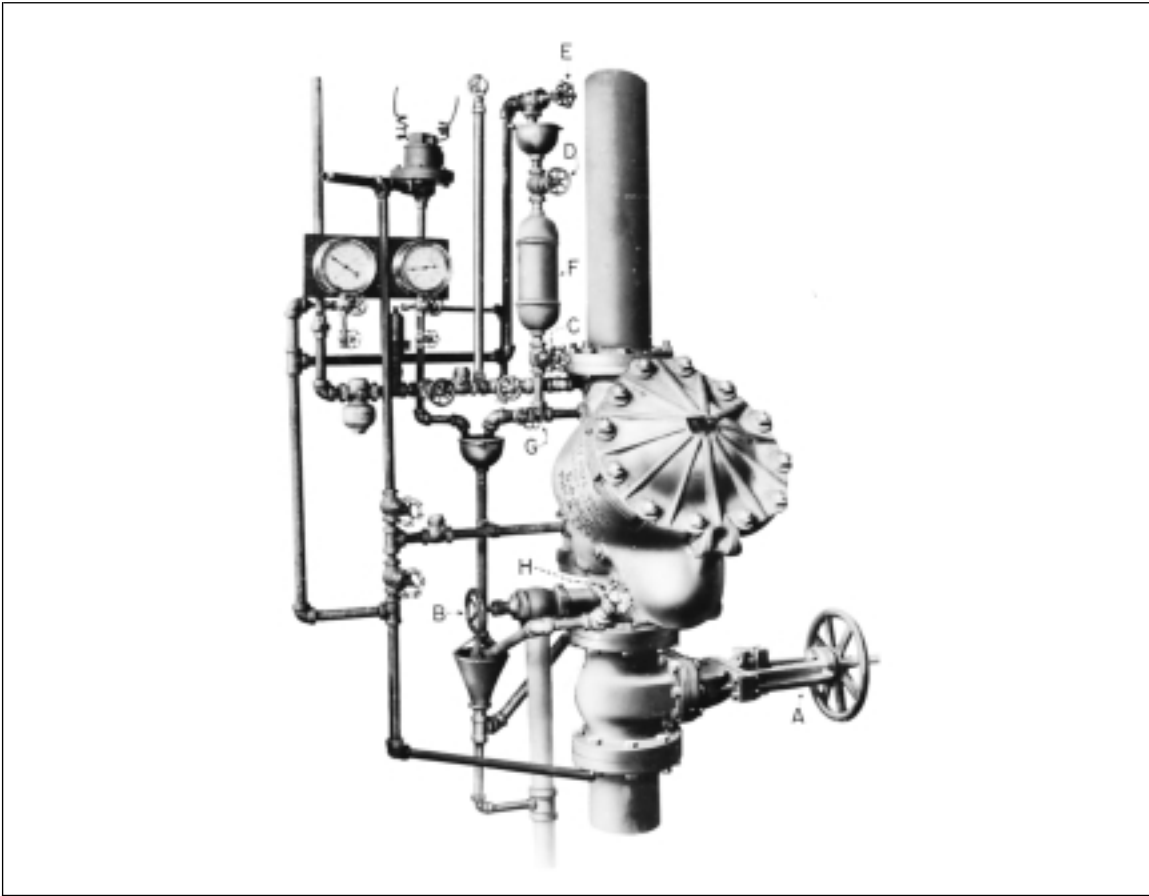

Fig. 63. Lewis dry-pipe valve Model B trim.

4. Carefully clean rubber facing 6, air seat 5, water seat 4, and retaining plate 9. Examine air clapper pin 7 and water clapper pin 8 for any scale.
5. Push air clapper 1 slowly towards its seat until water clapper 2 engages latch 10. Raise latch 10 by pushing upward on drip valve rod 11 which extends through the drip valve opening. The clappers should now fall to their respective seats.
6. Replace and tighten cover.
7. Open lower priming valve C and upper priming valve D. Open primary valve E; close when water has filled priming chamber F. Close lower priming valve C and upper priming valve D. Open test valve G; close when water has drained.
8. Pump air into the system.

Table 16

Highest Service Water Pressure or Fire Pump Pressure,								
<i>psi</i>			<i>(kPa)</i>			<i>(bar)</i>		
50			(345)			(3.45)		
75			(517)			(5.17)		
100			(689)			(6.89)		
125			(862)			(8.62)		
150			(1034)			(10.34)		
Highest Service Water Pressure or Fire Pump Pressure,			Air Pressure					
			Not less than			Not more than		
<i>psi</i>	<i>(kPa)</i>	<i>(bar)</i>	<i>psi</i>	<i>(kPa)</i>	<i>(bar)</i>	<i>psi</i>	<i>(kPa)</i>	<i>(bar)</i>
50	(345)	(3.45)	15	(103)	(1.03)	25	(172)	(1.72)
75	(517)	(5.17)	20	(138)	(1.38)	30	(207)	(2.07)
100	(689)	(6.89)	25	(172)	(1.72)	35	(241)	(2.41)
125	(862)	(8.62)	30	(207)	(2.07)	45	(310)	(3.10)
150	(1034)	(10.34)	35	(241)	(2.41)	50	(345)	(3.45)

9. Open wide the main control valve.
10. Make sure no leakage occurs at the drip valve.
11. Test the water supply by opening main drain valve B.

2.19 Manufacturers Model 3

Manufacturers Model 3 Dry-Pipe Valve

4-INCH AND 6-INCH (102-MM AND 152-MM), 1907 TO 1922

Automatic Sprinkler Co. of America, Youngstown, Ohio

DESCRIPTION

Manufacturers Model 3 is a mechanical dry-pipe valve. Pressure exerted on air discs 2 acts through a series of levers to hold water clapper 10 closed. The trip point of this valve is not affected (within limits) by the water pressure, but is somewhat affected by the force applied by adjusting nut 8. This valve is expected to trip at an air pressure of 10 to 15 psi (69 to 103 kPa) (0.69 to 1.03 bars).

Upon operation of a sprinkler, pressure is reduced in air chamber 1. Cam 14 and release arm 15 rotate, freeing vertical weight 7 from release lever 5. Weights 6 and 7 fall, freeing yoke lever 4 and allowing water pressure to force water clapper 10 open.

SETTING

1. Close main control valve.
2. Open main drain valve A (Fig. 65), auxiliary drain I, and all drawoff valves and vents at low points throughout the system; close them when water ceases to flow.
3. Remove cover 13 and carefully clean air clapper 12 and air seat 16. Place air clapper 12 on its seat and replac cover 13.
4. Remove air release cover 17, and carefully clean air disc 2 and its seat; then replace air release cover 17.
5. Prime air clapper 12 by opening upper priming valve B and lower priming valve D. Auxiliary drain I should be closed. Pour water into priming cup J and admit water to the level of priming water test E. Close lower priming valve D and fill priming chamber C with water; then close upper priming valve B.
6. Open lever cover 18; air stem 3 lifts slightly, and cam 14 and release lever 5 turn to a position where air stem 3 is dropped into the notch on cam 14.
7. Pump air into the system to 35 psi (241 kPa) (2.41 bars), holding air clapper 12 and air disc 2 to their respective seats.

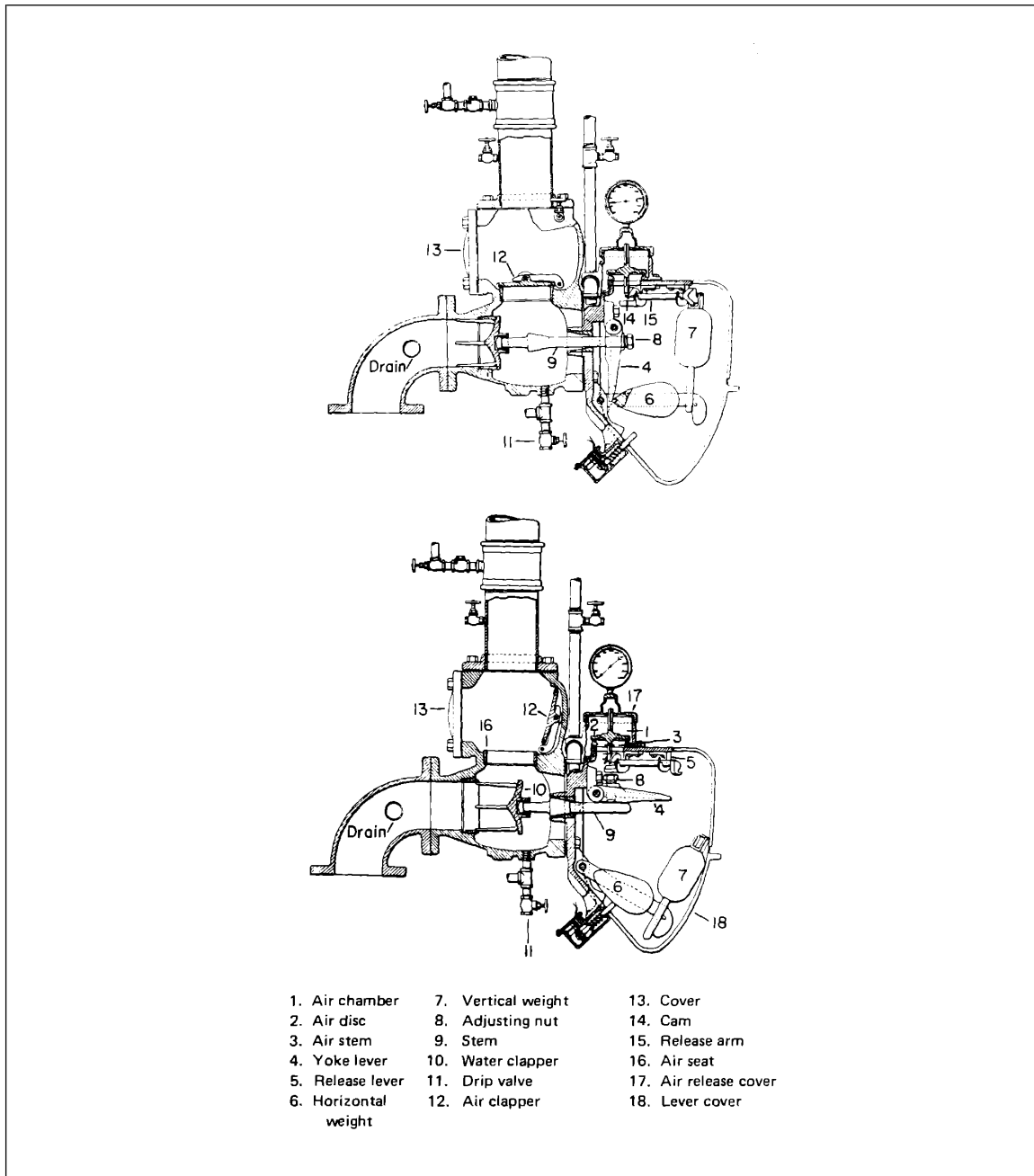

Fig. 64. Manufacturers Model 3 dry-pipe valve, internal views.

8. Push in stem 9 which brings water clapper 10 against its seat. Unscrew adjusting nut 8 a few turns and put yoke lever 4 in the vertical position so that vertical weight 7 can be placed on release lever 5. Tighten adjusting nut 8 sufficiently to hold yoke lever 4 in place.

9. Open drip valve 11 so that any leakage past water clapper 10 is detected.

10. Open main control valve **slightly** to allow water pressure against water clapper 10. Slowly tighten adjusting nut 8 until water stops leaking out of drip valve 11.

11. **Open wide the main control valve.**

12. If any water leaks, tighten adjusting nut 8.

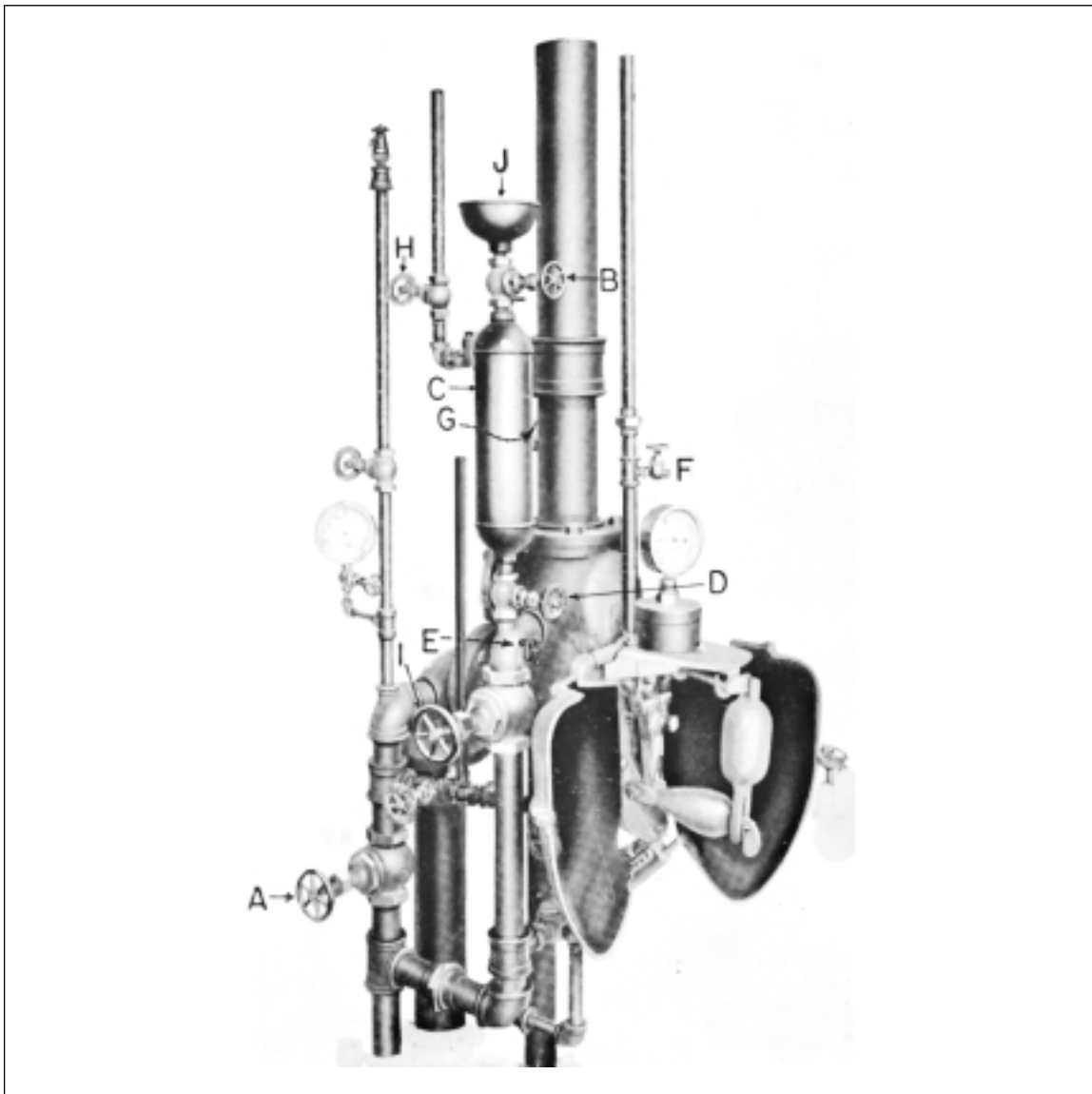

Fig. 65. Manufacturers Model 3 dry-pipe valve trim.

13. Test the water supply by opening main drive valve A.

TESTING

1. Open main drain valve A to check if the main control valve is open.
2. Open antiwater column air test F and drain any water. This is important because water could column in this pipe and prevent air disc 2 from operating.
3. Open air supply test G to make sure no water is above this level in the riser.
4. Open priming water test E. If air escapes, prime the dry valve to the level of priming test valve E.
5. Test the water supply by opening main drain valve A.

2.20 Matthew Hall Model MK II

Matthew Hall Model MK II Dry Valve

6 IN., 1970 TO DATE

Matthew Hall Mechanical Services Ltd. London W 1 England

DESCRIPTION

The Model MK II dry valve is a mechanical valve having no intermediate chamber. System air pressure, acting on diaphragm 14 (Fig. 67-A), creates a force which is transmitted through a series of levers to hold clapper 2 (Fig. 66) on its seat.

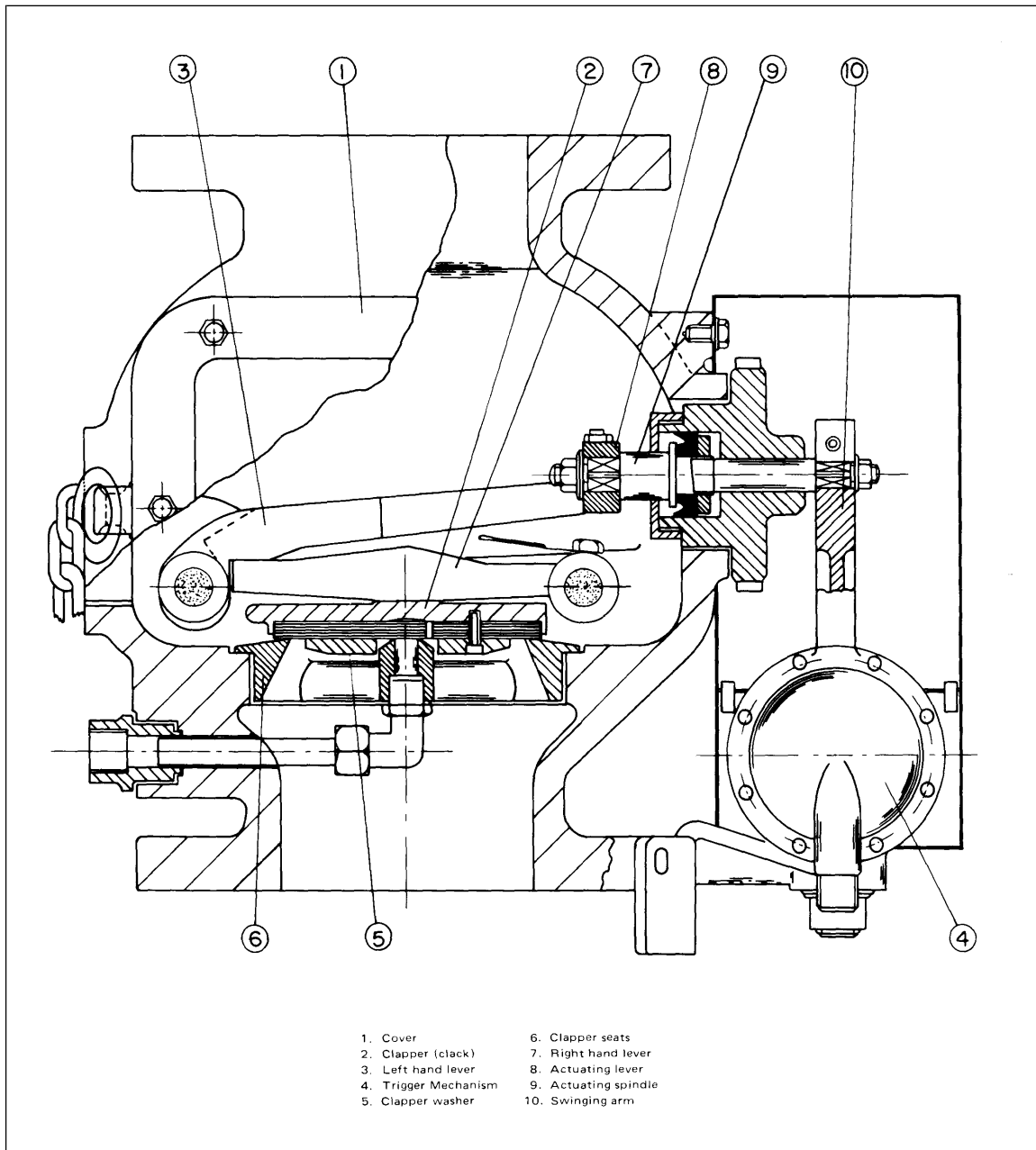

Fig. 66. Mathew Hall MK 11 dry-pipe valve.

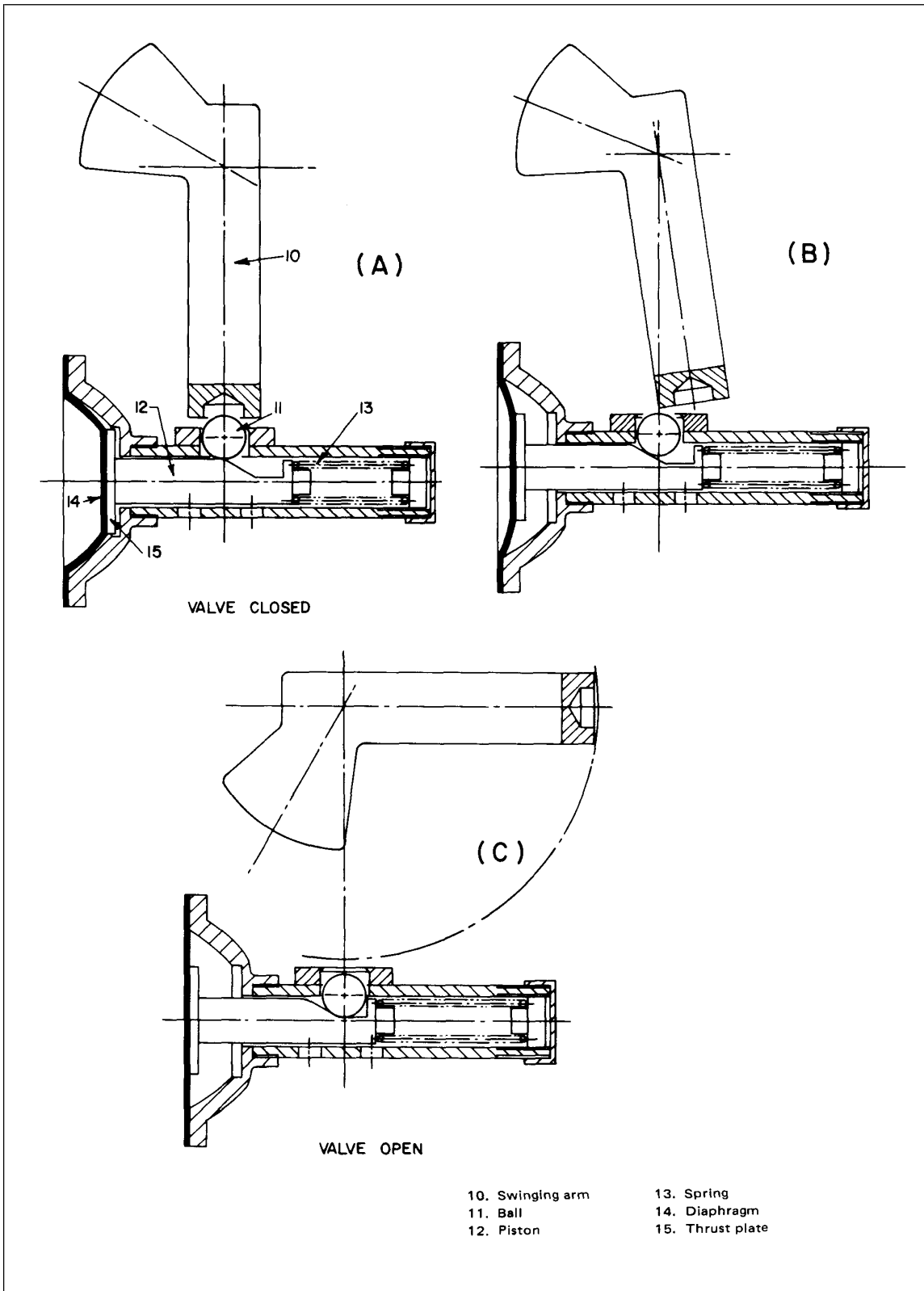

Fig. 67. Trigger mechanism.

The valve has no intermediate chamber. Therefore if water leaks by main clapper 2 (Fig. 66), it will build up in the riser. The dry valve could become inoperative if a large water column built up. A monitoring system is provided to give an electrical audible alarm and light indication when water level reaches about 6 inches above the water clapper.

In the resetting procedure a special wrench is used to move the levers into the set position. The wrench could be left attached to the lever system making the valve inoperative. To compensate, a snap switch attached to the cover will energize an audible alarm and indicating light whenever the cover is raised.

OPERATION

Refer to Fig. 66 and 67. When the dry valve is in set position, clapper 2 rests on clapper seats 6. System air pressure applied to diaphragm 14 acts through a series of levers to hold clapper 2 in the set position. When system air pressure is reduced sufficiently, pressure on diaphragm 14 (Fig. 67) in the triggering mechanism is decreased. This allows the spring loaded piston 12 (Fig. 67) with thrust plate 15 (Fig. 67) to move, permitting ball 11 (Fig. 67) to drop into the slot (shown in Fig. 67A, B, and C). This releases swinging arm 10 permitting the actuating spindle 9 to rotate. Actuating lever 8 now moves to release left hand lever 3 and right hand lever 7. Water pressure can now force clapper 2 open and the port to the waterflow alarm lines.

SETTING

1. Close isolating valve G (Fig. 68).
2. Close main control valve A.
3. Open main drain valve B, test valve F, and all drawoff valves and vents at low points throughout the system, closing them when water ceases to flow.
4. Remove screw plug J and open air drain valve K to allow pipe to drain. Close valve and replace plug when drained.
5. Remove cover of the valve.
6. The right hand lever 7 Fig. 66 should be supporting clapper 2 in the open position. Clean clapper seats 6 and clapper washer 5.
7. Lower clapper 2 onto its seats. Place right hand lever 7 on top of clapper 2 and left hand lever 3 on top of right hand lever 7.
8. Open cover of triggering mechanism L (Fig. 68).
9. Fit claw of the special spanner wrench over the counter-weight of swinging arm 10. Turn spanner so that actuating lever 8 will apply pressure to left hand lever 3 and the swinging arm 10 engages the diaphragm ball lock (Fig. 67). Secure the spanner in position by standing its strut on the trigger mechanism housing.
10. Cover the clapper 2 with water.
11. Replace cover of the dry valve.
12. Open air supply valve H, allowing pressure to build up to 30 psi. Shut air supply valve H.
13. Check that swinging arm 10 is engaged in ball lock position (Fig. 67).
14. Check pressure gauge for any pressure leakage. If no leakage, disengage spanner wrench from the counter-weight of swinging arm 10.
15. Partially open main control valve A slowly and check for leaks.
16. Open alarm isolating valve G.
17. Open main control valve A fully.

2.21 Niagara Model G D

Niagara Model G Dry-Pipe Valve

4-IN. AND 6-IN. (102-MM and 152-MM, 1915 TO 1921

“Automatic” Sprinkler Co. of America, Youngstown, Ohio

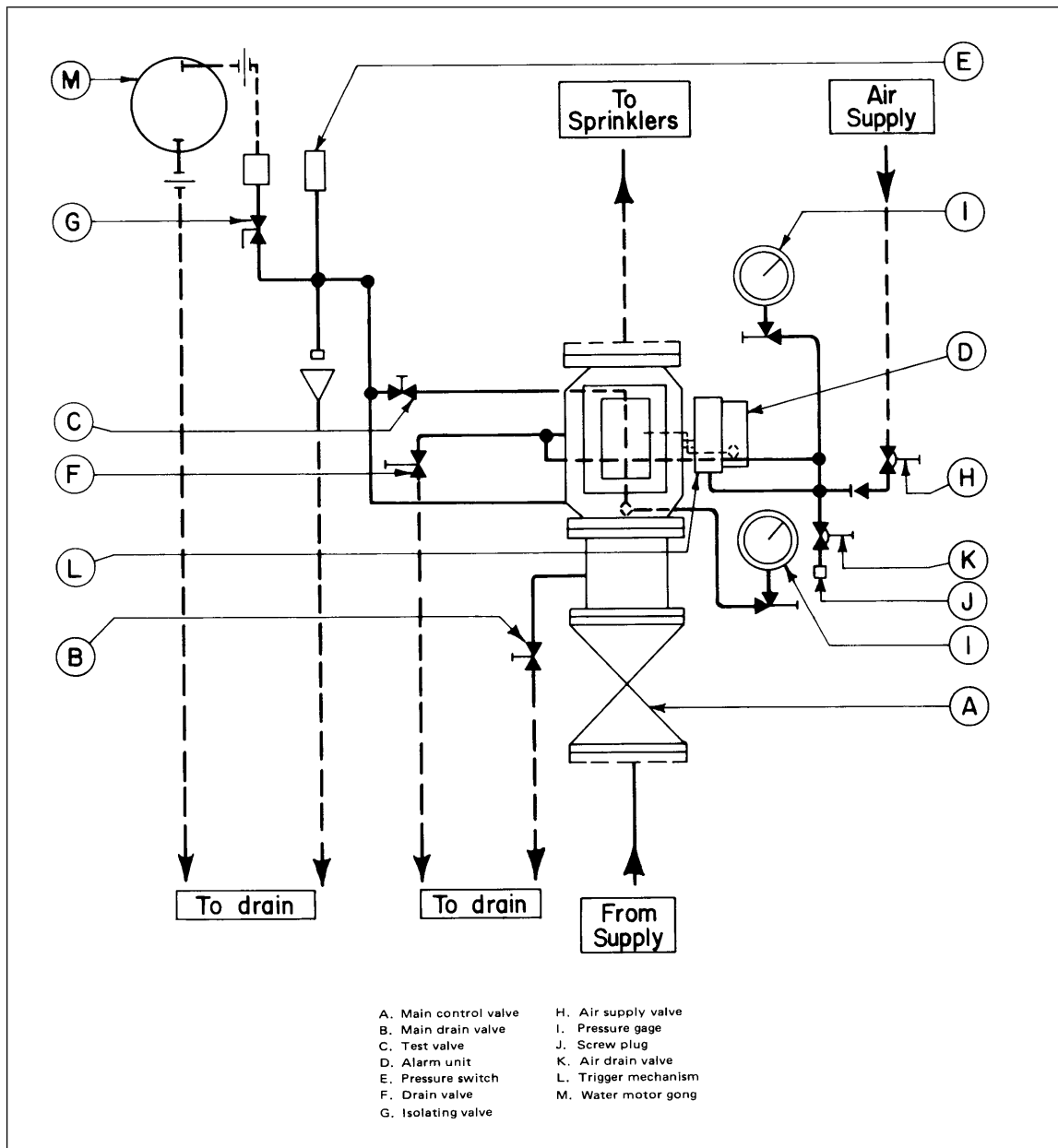

Fig. 68. Schematic of installation.

DESCRIPTION

Niagara Model G dry valve (Fig. 69) is similar to Models D, E, EE, and F dry valves which “Automatic” Sprinkler Co. produced from 1908 to 1915. The Model G is a mechanical valve in which pressure exerted on air disc 1 acts through a series of levers to hold water clapper 2 closed.

When system air pressure drops to the trip point of the valve, pressure on air disc 1 also drops. Trip lever 3 moves allowing weight 4 to drop. Plunger 5 is now free to move carrying with it upper strut 6 and lower strut 7. Water pressure now forces water clapper 2 open.

SETTING

1. Close the main control valve.

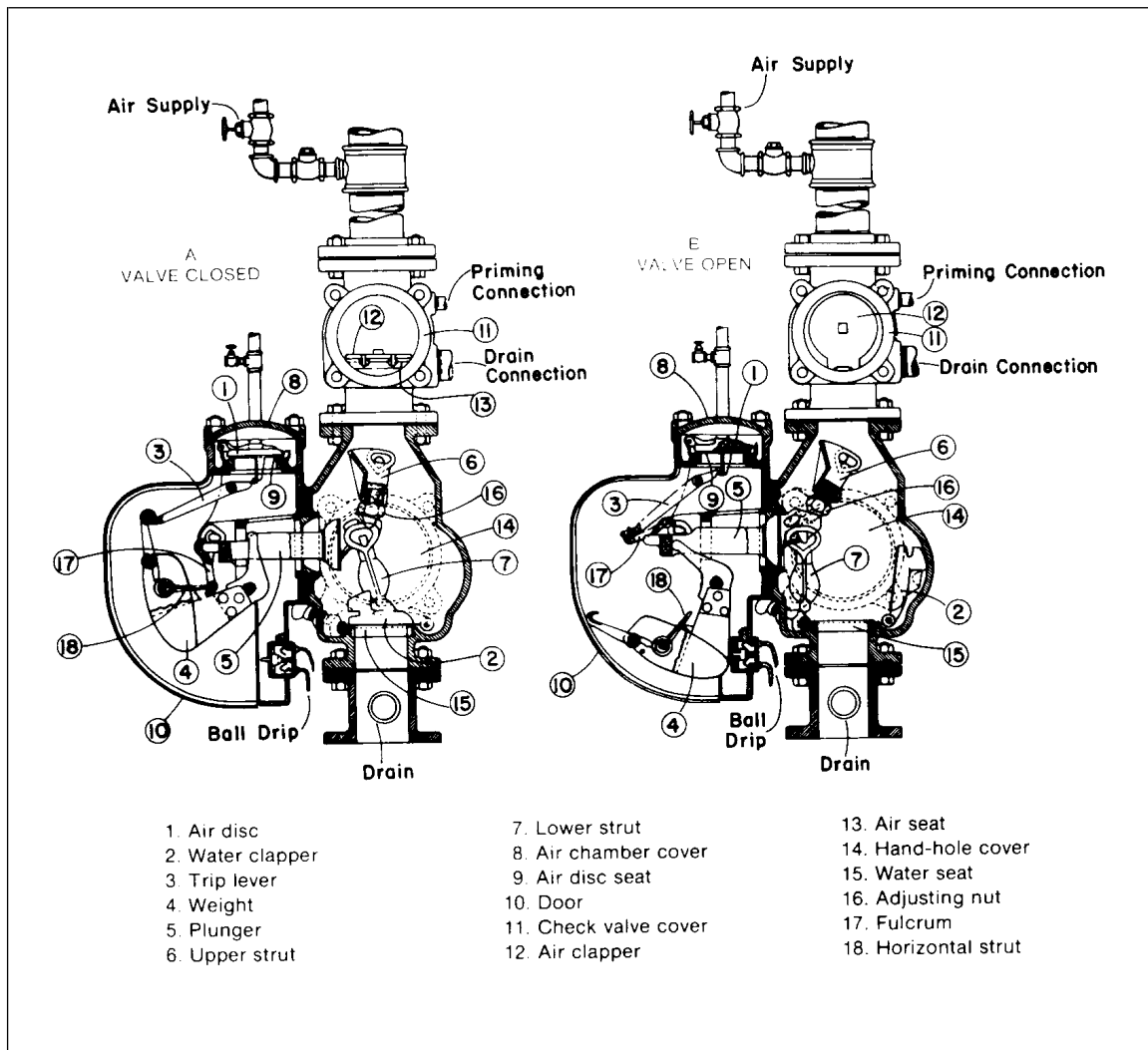

Fig. 69. Niagara Model G dry-pipe valve, internal views

2. Open main drain valve A (Fig. 70), auxiliary drain valve B, and all drawoff valves and vents at low points throughout the system. Close them when water ceases to flow.
3. Remove air chamber cover 8 (Fig. 69) and carefully clean air disc 1 and air disc seat 9. Replace air chamber cover 8 when finished.
4. Open door 10 of the dry valve and place one end of trip lever 3 under air disc 1.
5. Remove check valve cover 11 and carefully clean air clapper 12 and air seat 13. Place air clapper 12 on its seat and replace cover 11.
6. Remove hand-hole cover 14 and carefully clean water clapper 2 and water seat 15. Place water clapper 2 on its seat.
7. Add priming water over air clapper 12 by opening upper priming valve C (Fig. 70), lower priming valve D, and test valve H. Admit water to priming cup E until water flows from test valve H. Close lower priming valve D and add water to priming chamber I; then close upper priming valve C and test valve H.
8. Add priming water over air disc 1 (Fig. 69), using same procedure as in step 7.
9. Pump the required air pressure (25 psi to 35 psi (172 kPa to 241 kPa)) by opening air supply valve G. Close tightly when finished.

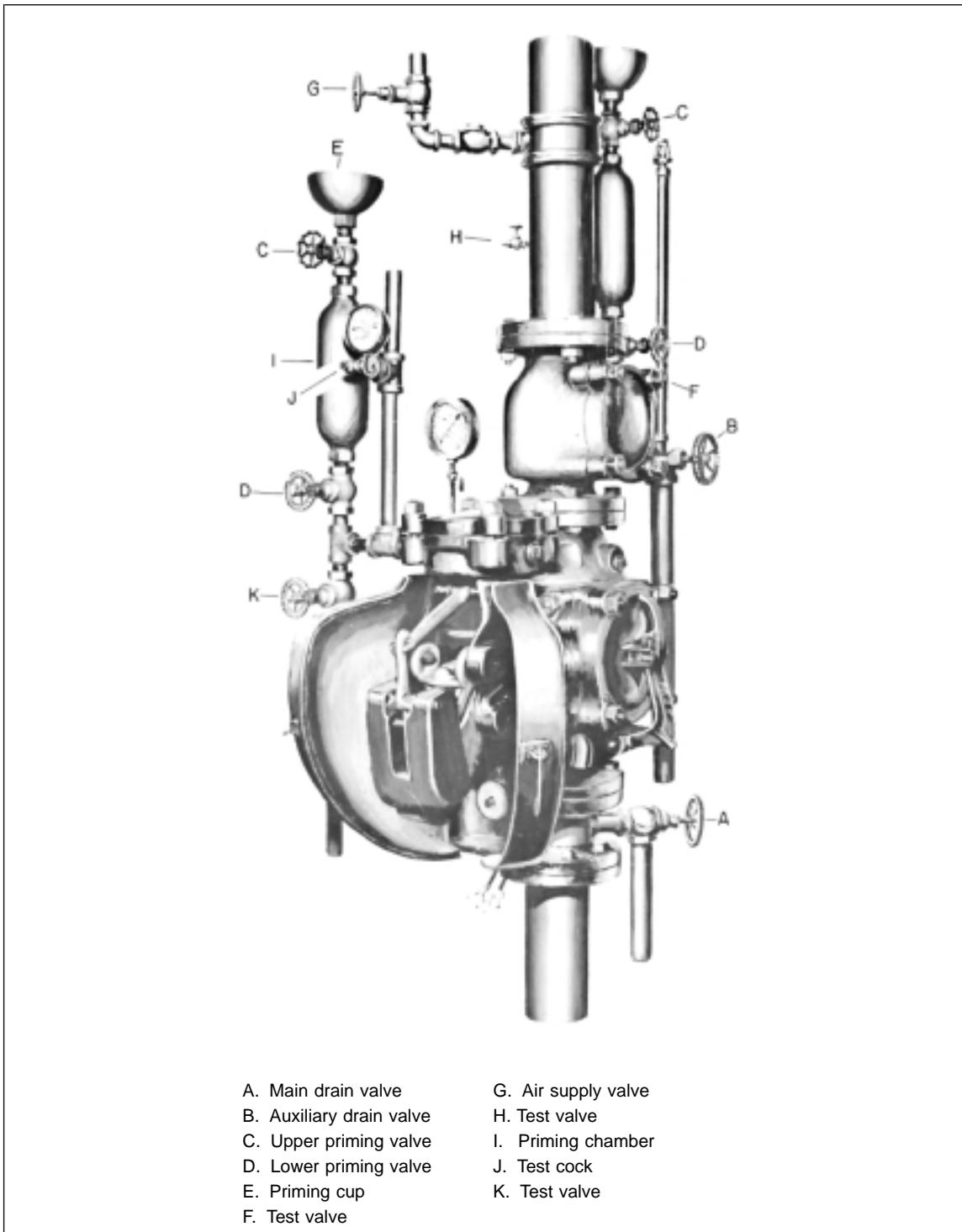

Fig. 70. Niagara Model G dry-pipe valve, with trim

10. Loosen adjusting nut 16 (Fig. 69), and with one hand raise weight 4 pushing plunger 5 into the main body of the valve. With the other hand, upper strut 6 and lower strut 7 are placed in a position as shown in Fig. 69-A. Fulcrum 17 and horizontal strut 18 are also placed as shown in Fig. 69-A. Weight 4 is now hooked to trip lever 3. Adjusting nut 6 is screwed hard into its socket at the end of plunger 5.

11. Replace hand-hole cover 14 and close door 10.

12. **Slowly open main control valve wide.**
13. Test the water supply by opening main drain valve A (Fig. 70).

TESTING

1. Check that the main control valve is wide open.
2. Open test cock J (Fig. 70). If water appears, draw it off because water columning in this line could prevent the valve from operating.
3. Open test valve H and draw off any excess water.
4. Open test valves K and F to see if there is an ample supply of priming water. If air escapes, priming water should be added to the appropriate level.
5. Test the water supply by opening main drain valve A (Fig. 70).

SPECIAL STOP FOR AIR CLAPPER

Experience has shown that if water flows in a reverse direction through nearly all the different models of Niagara dry-pipe valves, air clapper 12 (Fig. 69) will, under certain conditions, be slammed upon its seat so suddenly that the resulting water hammer is sufficient to break the body casting. This is most likely to happen where a number of valves are connected to a common header and are tripped in succession, the sudden discharge of water into the empty systems lowering the pressure in the header sufficiently to cause a reverse flow through the first valve operated.

To overcome this problem, the manufacturer has provided a special cover for the air valve with a projection on the inside to prevent the clapper opening beyond dead center (Fig. 71). This is applicable for Model E, made after March, 1909, and for Models EE, F, and G. A slight boss on the outside of the cover is provided to indicate that there is a stop on the inside.

2.22 Preussag Model TAV-FM

Preussag Model TAV-FM Dry-Pipe Valve

80 mm (3 in.), 1976 to Date
100 mm (4 in.), 1976 to Date
150 mm (6 in.), 1976 to Date

Preussag Aktiengesellschaft Feuerschutz and Minimax GmbH 206 Bad Oldesloe, W. Germany

DESCRIPTION

The Preussag Model TAV-FM is a differential-type dry-pipe valve with an average water-to-air differential of 5.7:1.0. The valves listed above are identical in design and differ only in size. Each has a dual rated working pressure of 10 bars (145 psi) (1000 kPa) to comply with German standards, and 175 psi (1207 kPa) (12.1 bars) to comply with Factory Mutual requirements.

The company logo, SFH, is cast in raised letters on the cover plate.

The Model TAV-FM valve does not have a threaded air supply opening in the valve body. Instead, the air supply line is piped directly into the riser of the sprinkler system.

OPERATION

When the valve is in the set position (Fig. 72), clapper 1 rests on water seat 8 and air seat 10. Water gasket 7 and air gasket 3 help to maintain a seal at the seats. Priming water on top of clapper 1 also helps to seal air seat 10. System air pressure fills the space above the priming water, providing clapper 1 with adequate force to resist supply water pressure beneath the clapper.

When system air pressure is reduced sufficiently (usually through operation of one or more sprinklers), the supply water pressure forces clapper 1 to swing open on clapper arm 2. Clapper arm 2 is attached to valve body 13 by clapper arm hinge pin 4. When the flow of water ceases, clapper 1 is held open in one of two positions. This occurs when latch 11 engages one of the two clapper stops 12, which are cast into the inside surface of valve body 13.

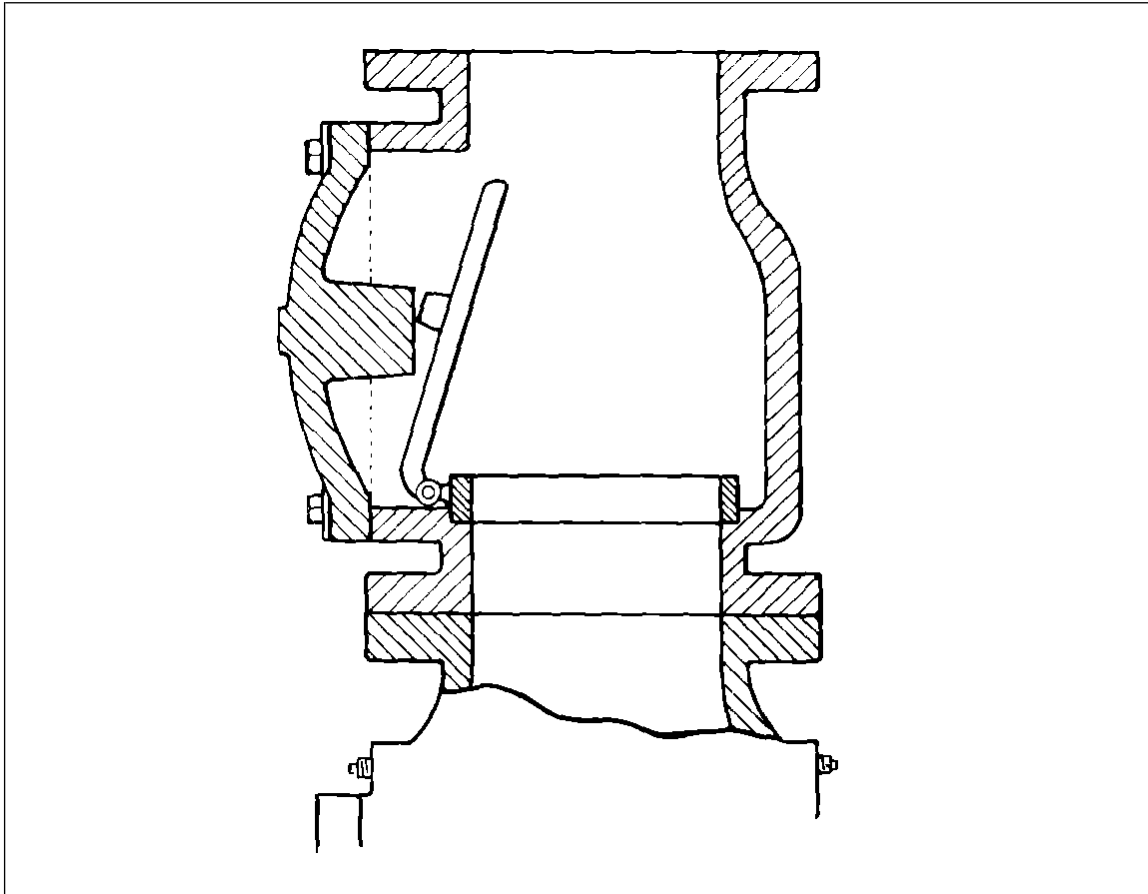

Fig. 71. Air check valve showing special cover with internal stop for air clapper (Model E made after March 1909 and Models EE, F, and G dry-pipe valves).

RESETTING

1. Close the main control valve supplying water to the system.
2. Open main drain valve A (Fig. 73) and all draw-off valves and vents at low points throughout the system. Close them when water ceases to flow.
3. Remove cover plate 14 and lift clapper 1 onto its second stop.
4. Clean water seat 8, air seat 10, water gasket 7, and air gasket 3. Remove any scale on body wall in pocket 5.
5. Unlatch clapper 1 and place it on water seat 8 and air seat 10. Replace and tighten cover plate 14. Check that all drain valves are closed. Put lever of 3-way cock L in OPERATION position.
6. Open priming valve M. Open the priming valve (not shown) which fills priming cup C. (Priming water will accumulate above clapper 1.) When water level reaches priming cup C, close priming valve M. Open priming water level control valve B and drain off surplus water. Then close this valve.
7. Open air supply valves F and admit sufficient air into the system to hold clapper 1 closed against maximum water pressure as indicated in Table 17.
8. When the required air pressure has been established in the system, tightly close air supply valves F. Inspect drip valve opening K for possible priming water leakage past air seat 10.

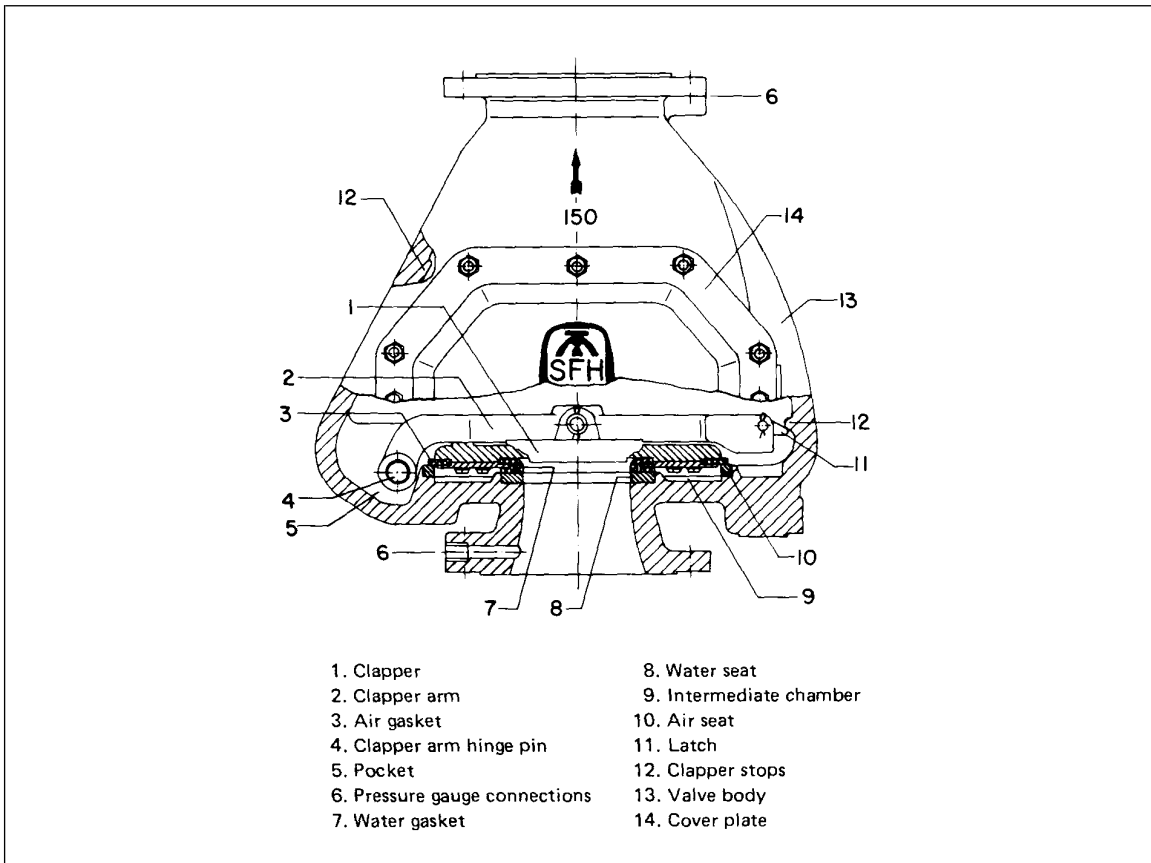

Fig. 72. Preussag Model TAV-FM dry-pipe valve.

Table 17. System Air/Water Pressure.

Maximum Water Pressure			Air Pressure					
			Not Less Than			Not More Than		
psi	(kPa)	(bars)	psi	(kPa)	(bars)	psi	(kPa)	(bars)
50	(345)	(3.5)	15	(103)	(1.0)	25	(172)	(1.7)
75	(517)	(5.2)	20	(138)	(1.4)	30	(207)	(2.1)
100	(689)	(6.9)	25	(172)	(1.7)	35	(241)	(2.4)
125	(862)	(8.6)	30	(207)	(2.1)	40	(276)	(2.8)
150	(1034)	(10.3)	35	(241)	(2.4)	45	(310)	(3.1)
175	(1207)	(12.1)	40	(276)	(2.8)	50	(345)	(3.5)

9. Open the main water control valve slightly and again check drip valve opening K to assure that there is no leakage past water seat 8. If no leakage is observed, air and water seats are tight. Open main control valve wide (slowly, to avoid raising clapper and tripping the valve) and lock valve.

10. Test water supply by opening main drain valve A. Dry-pipe valve is now reset and sprinkler system is restored to service.

TESTING THE ALARM

1. If pressure switch J is connected to an external alarm system, notify the proper persons before testing.
2. Turn 3-way cock lever L to TEST position. Water will flow from below clapper 1 through water pressure gauge connection 6 to the turbine of water motor gong I.
3. To stop the alarm, turn the lever of the 3-way cock to position O and then back to position OPERATION. The alarm line should drain automatically through drip valve K.

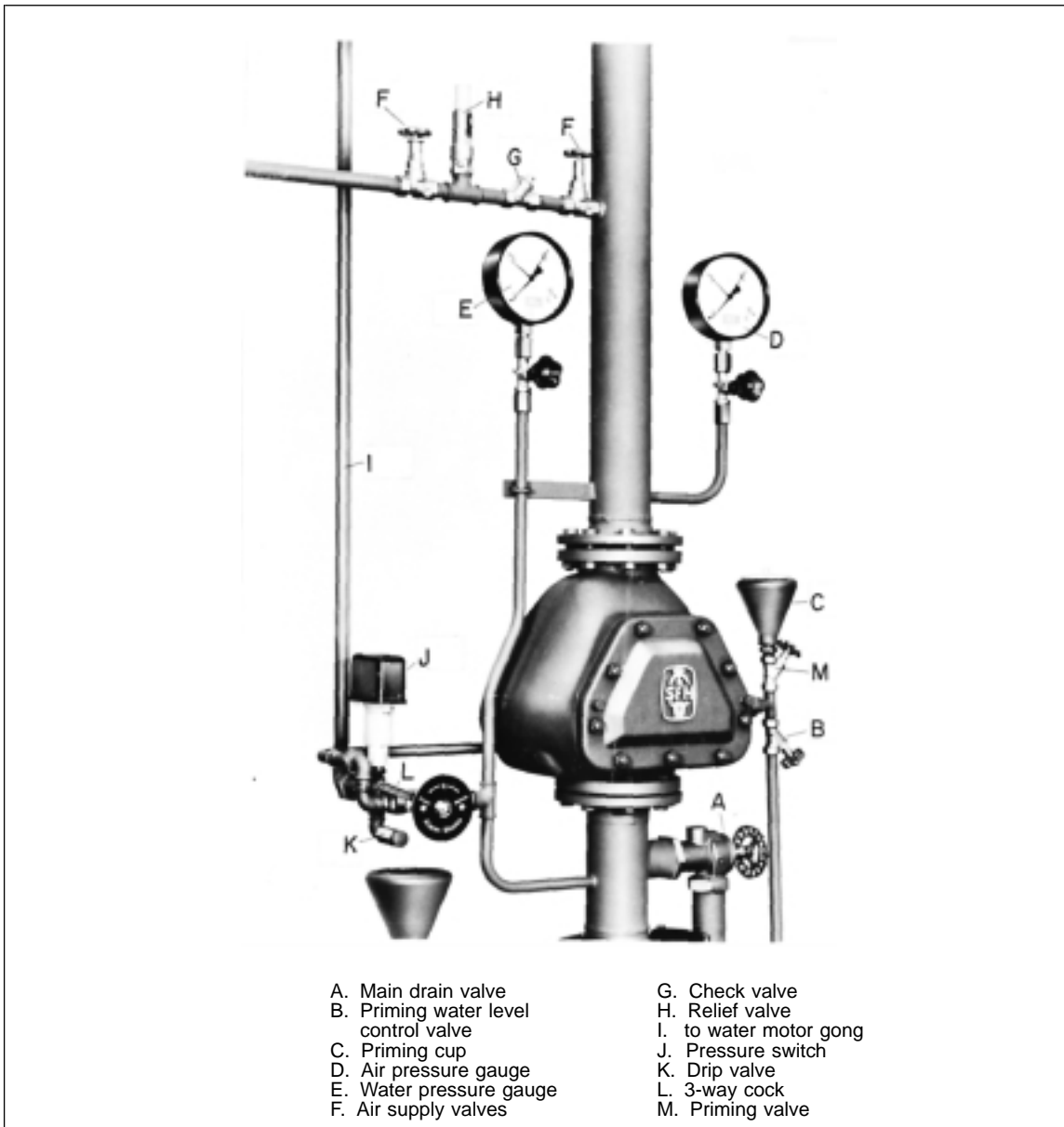

Fig. 73. Trim on Preussag Model TAV-FM dry-pipe valve.

4. If the water column in the alarm line prevents drip valve K from opening automatically, press the red button of drip valve K to drain.

2.23 Reliable Models B, C, C-1, C-2, and D

Reliable Dry-Pipe Valves

The Reliable Model D dry-pipe valve has been added to D.S. 2-25. The Model D is FM-Approved (1976 to date) and replaces the Model C-2 Valve.

RELIABLE MODEL D DRY-PIPE VALVE

4-in. (102-mm) 1976 To Date

6-in. (152-mm) 1976 To Date

Reliable Automatic Sprinkler Co., Mt. Vernon, New York

DESCRIPTION

The Reliable Model D is a differential type valve with an average water-to-air differential of 5.7:1.0. Working on the same principle as other differential dry-pipe valves, the Model D is designed so that a moderate air pressure will hold back a much greater water supply pressure. The necessary differential is created by the difference in area upon which the water pressure and air pressure act.

The valves listed above are identical in design and differ only in size. Each has a rated working pressure of 175 psi (1207 kPa, 12.1 bar.)



Fig. 74. Reliable Model D Dry-pipe valve.

OPERATION

When the valve is in the set position, clapper 4 and rubber facing 6 rest on air seat 7 and water seat 9. The rubber facing helps to maintain a seal at the seats. Priming water on top of clapper 4 also helps to seal air seat 7. System air pressure fills the space above the priming water, providing clapper 4 with adequate force to resist supply water pressure beneath the clapper.

When system air pressure is reduced sufficiently (usually through operation of one or more sprinklers), the supply water pressure forces clapper 4 to lift from seats 7 and 9. Clapper 4 then rotates, at hinge pin 14, out of the waterway. Water also flows from intermediate chamber 17 through alarm connection 18 to electric alarm switch J and water motor gong piping K, automatically sounding an alarm. When the flow of water ceases, clapper 4 is held open in one of two positions. This occurs when latch 5 engages one of the two latch notches 2 which are cast into the inside surface of valve body 3.

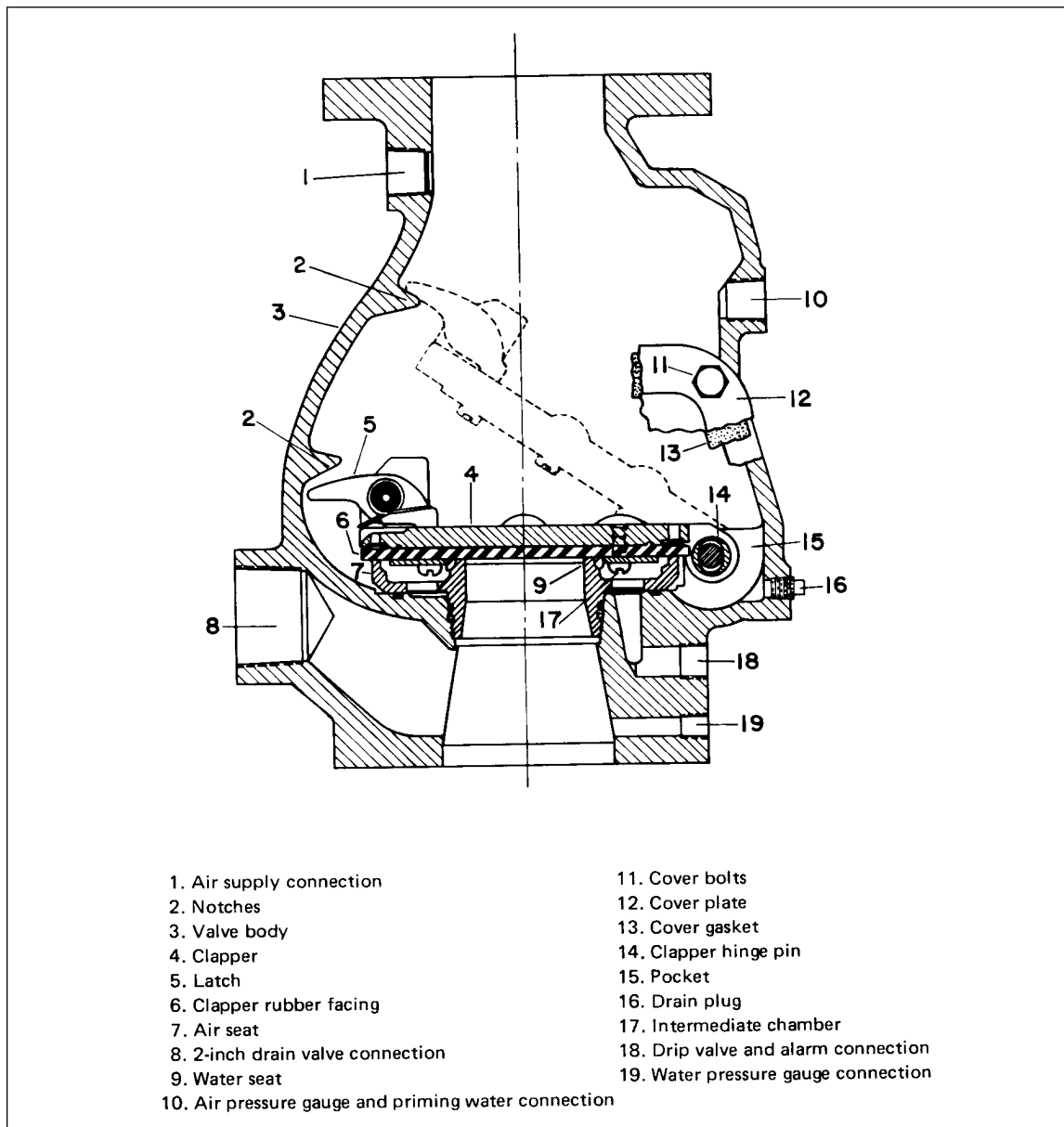

Fig. 75. Reliable Model D dry-pipe valve, cross section

RESETTING

1. Close the main control valve supplying water to the system.
2. Open main drain valve B and all draw-off valves and vents at low points throughout the system. Close them when water ceases to flow.
3. Push in plunger of ball drip valve D to force ball from its seat. Water column in piping to alarms will drain into drip cup E.
4. Remove drain plug 16 to drain body of dry-pipe valve. Replace drain plug securely when flow of water has stopped.
5. Remove cover plate 12 and raise clapper 4 by lifting under rubber facing 6. Latch clapper 4 onto its second latch notch.



Fig. 76. Trim on Reliable Model D dry-pipe valve

6. Clean air seat 7 and water seat 9. Inspect and clean rubber facing 6. Remove any scale on body wall in pocket 15.
7. Release latch 5 by lifting and holding clapper 4 slightly above the second latch notch. Push the front tip of latch 5 down and hold it in this tipped position. Lower clapper 4 onto water seat 9 and air seat 7.
8. Center the location diameter of clapper rubber facing 6 around water seat 9. Clapper 4 should sit flat with a minimum of movement when the seating is correct.
9. Check that all drain valves are closed. Open priming water level control valve F and priming valve C. Open the priming valve (no shown) which fills priming cup H. Priming water will accumulate above clapper 4. When water flows into drip cut E from priming water level control valve F, priming water is at proper level. Close valves G and F. Check ball drip valve D for possible priming water leakage past air seat 7.
10. Open air supply valve A and admit sufficient air into the system to hold clapper 4 closed against maximum water pressure as indicated in Table 18.

Table 18. System Air/Water Pressure

Maximum Water Pressure			Air Pressure					
			Not less than			Not more than		
psi	(kPa)	(bar)	psi	(kPa)	(bar)	psi	(kPa)	(bar)
50	(345)	(3.5)	15	(103)	(1.0)	25	(172)	(1.7)
75	(517)	(5.2)	20	(138)	(1.4)	30	(207)	(2.1)
100	(689)	(6.9)	25	(172)	(1.7)	35	(241)	(2.4)
125	(862)	(8.6)	30	(207)	(2.1)	45	(276)	(2.8)
150	(1034)	(10.3)	35	(241)	(2.4)	50	(345)	(3.5)

11. When the required air pressure has been established in the system, tightly close air supply valve A. Again inspect ball drip valve D for possible priming water leakage past air seat 7.
12. Open the main water control valve slightly and check ball drip valve D to assure that there is no leakage past water seat 9. If no leakage is observed, air and water seats are tight. Open main control valve wide (slowly, to avoid raising clapper and tripping the valve) and lock valve.
13. Test water supply by opening main drain valve B. Dry-pipe valve is now reset and sprinkler system is restored to service.

RELIABLE MODEL B DRY-PIPE VALVE
6-in. (152-mm) 1925 To 1941*

Reliable Automatic Sprinkler Co., Mt. Vernon, New York

The reliable Model B dry-pipe valve (Fig. 77) is of the differential (6.0 to 1) type. The water clapper is counter-balanced and is hinged inside the dome-shaped air clapper. The clappers can be removed from the valve in a unit for cleaning or repair simply by lifting them out of the body.

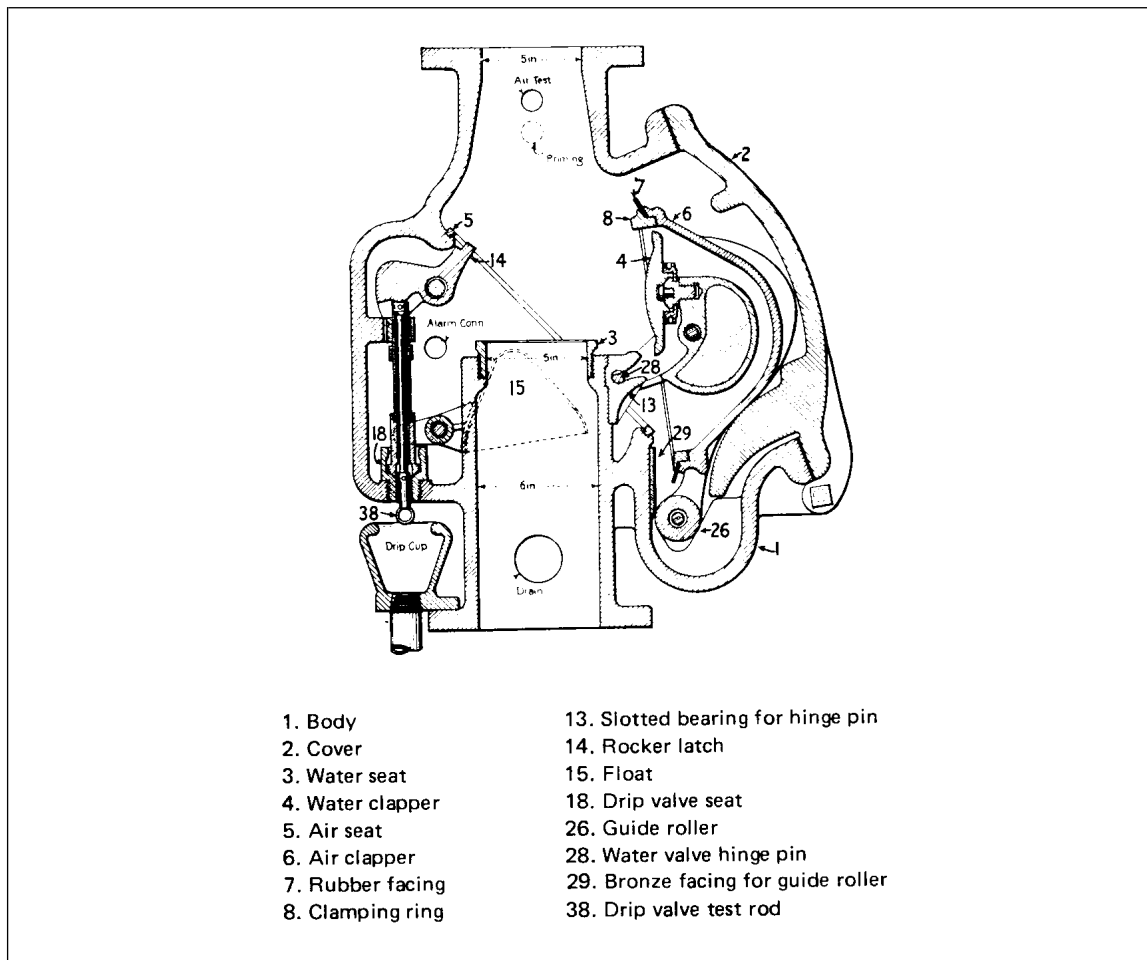

Fig. 77. Reliable Model B dry-pipe valve.

To set the valve, push air clapper 6 slowly from the hand hole in an upward direction until it drops onto its latch. Clappers are then released from their latch 14 and dropped onto their seats by lifting up on the latch rod 38. Bolt the hand cover in place. Admit priming water through the priming chamber to the level of valve 52 (Fig. 78) and then pump up the required air pressure in the system. Open main gate valve 73. Make sure that no leakage appears at drip valve seat 18. Open drain valve 67 to test the water supply. Put the priming apparatus in service.

*Model A (1922-1925) is of similar design except that the waterway at the inlet end is tapered and the outlet end is 6 inch (152-mm).

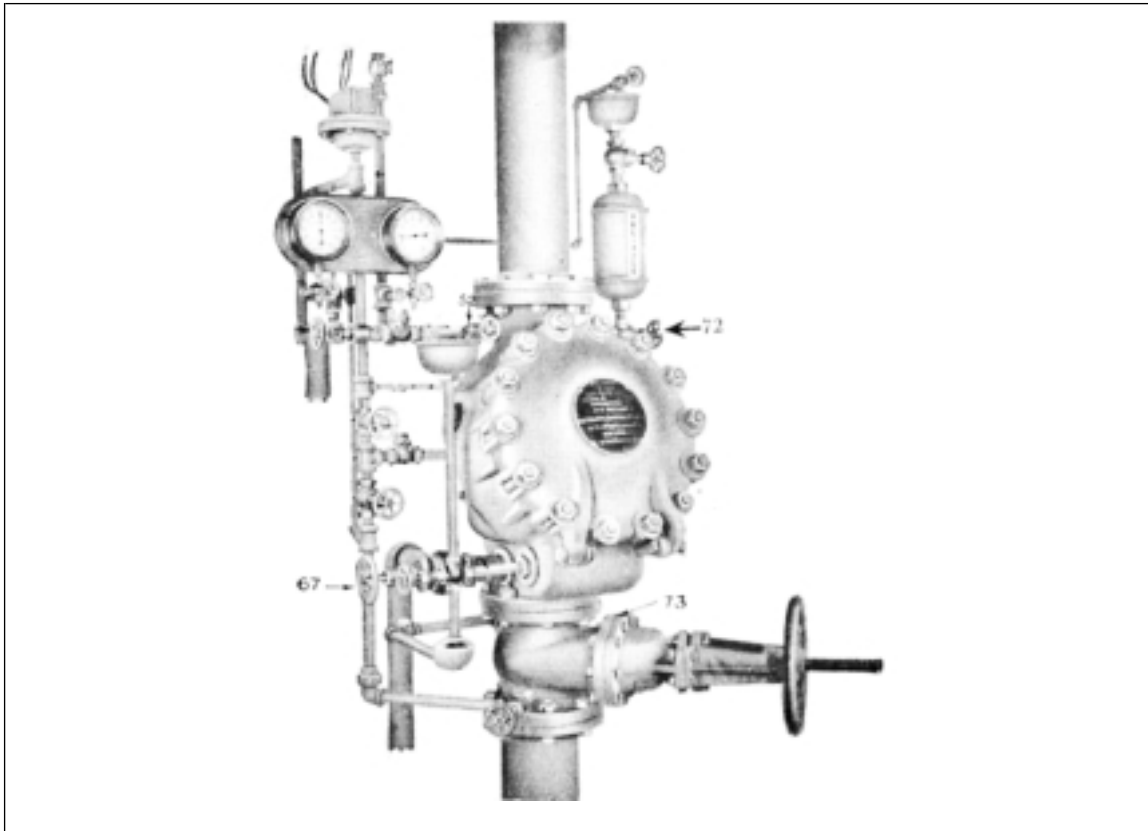

Fig. 78. Reliable Model B dry-pipe valve as installed with trim.

RELIABLE DRY-PIPE VALVES

Model C 6-in. (152-mm) 1941 To 1958*

Model C-1 4&6-in. (102-152-mm) 1958 To 1972

Model C-2 4&6-in. (102-152-mm) 1972 To 1976

Reliable Automatic Sprinkler Co., Mt. Vernon, New York

The Models C-1 and C-2 valves are identical. The Model C-1 valve is the same as the Model C except for modifications of the trimming hole bosses (Fig. 79).

*The 6-inch (152-mm) Model C was also made for Raisler Sprinkler Corp., with "Raisler Model C" marked on cover of valve.

The 4-inch (102-mm) Model C-1 valve is the same as the 6-inch (152-mm) Model C-1 except for minor changes in arrangement and shape of clapper arms (15 and 19) and lever latches 18 and 20. Also, another arrangement is substituted for the clapper latch 17.

The Model C valve is a differential type (average 6.1 to 1) having a single swing clapper 10 with a combined air and water medium hard rubber facing 11. The air and water seats are tinned to prevent sticking of rubber. The 4-in. (102-mm) valve has an average differential of 5.9 to 1.

The clapper is hinged at three points 16, one at the rear and one on each side in the intermediate space of the valve. Latching levers 18 and 20 are hinged to the side levers and serve as props to prevent the clapper returning to seats with reverse flow. On the 6-inch (152-mm) valve, latch 17 on the toe of the clapper engages steps cast on the cover; this prevents the clapper from reseating. On the 4-inch (102-mm) valve, a spring-operated "L" shaped latch is hinged to the cover and swings towards the center when the clapper lifts; this prevents reseating.

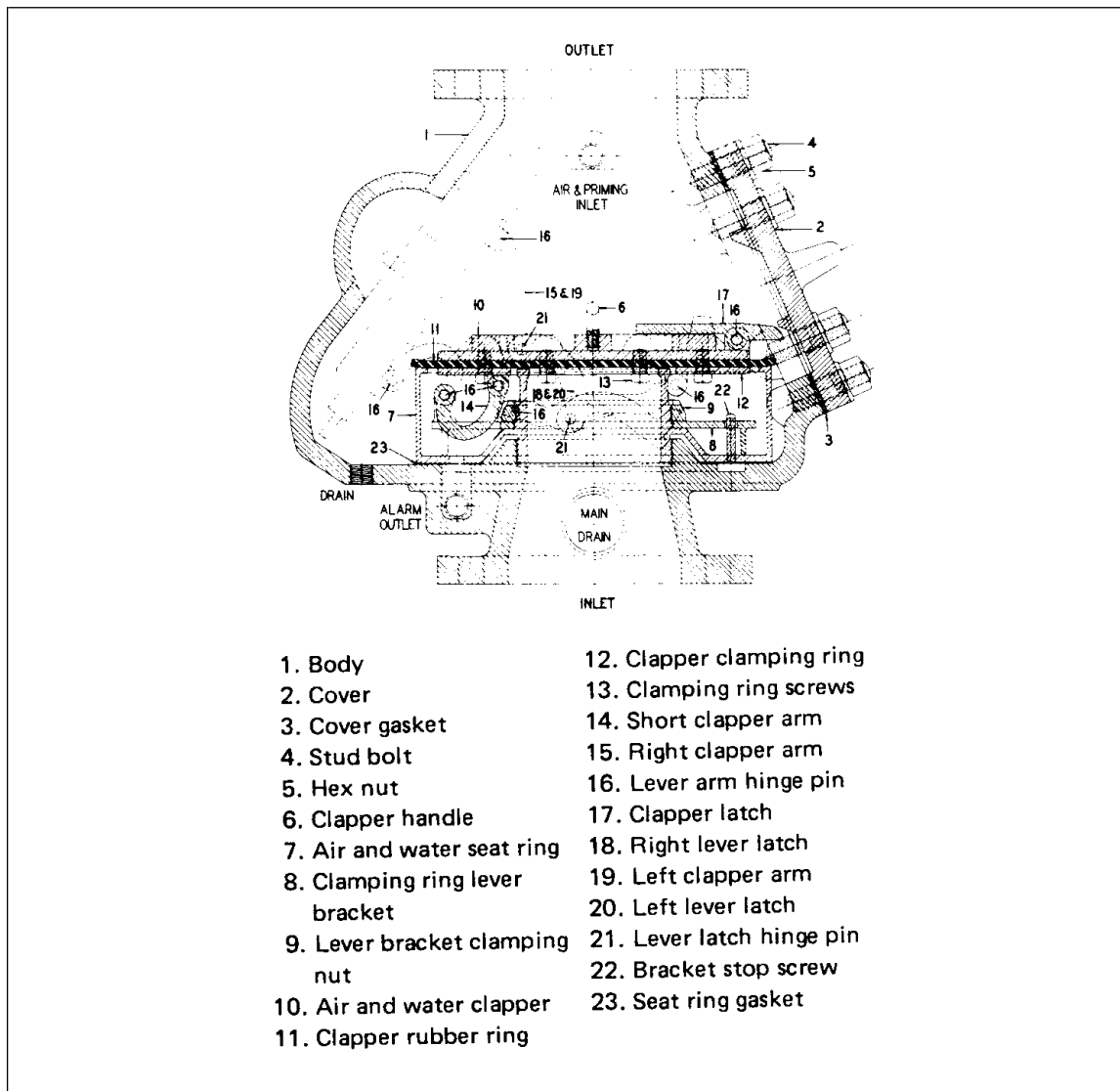

Fig. 79. Reliable Model C dry-pipe valve.

To set this valve, drain the system and remove the cover. Carefully clean the seats and replace the clapper on the seat. Replace the cover and add priming water through the priming connection until water flows from the air test connection. Then build up air pressure in the system to the proper point and open the water supply valve wide.

Make sure the velocity drip A is open by pushing plunger, and check for leakage past the water seat of the dry-pipe valve.

2.24 Rockwood Models A and B

Rockwood Dry-Pipe Valves

MODEL A 3-, 4-, 5-, 6-INCH (76-, 102-, 127-, 152-MM), 1908 TO 1927

MODEL B 6-INCH (152-MM), 1927 TO 1929

Firematic Sprinkler Devices Inc., Worcester, Mass.

DESCRIPTION

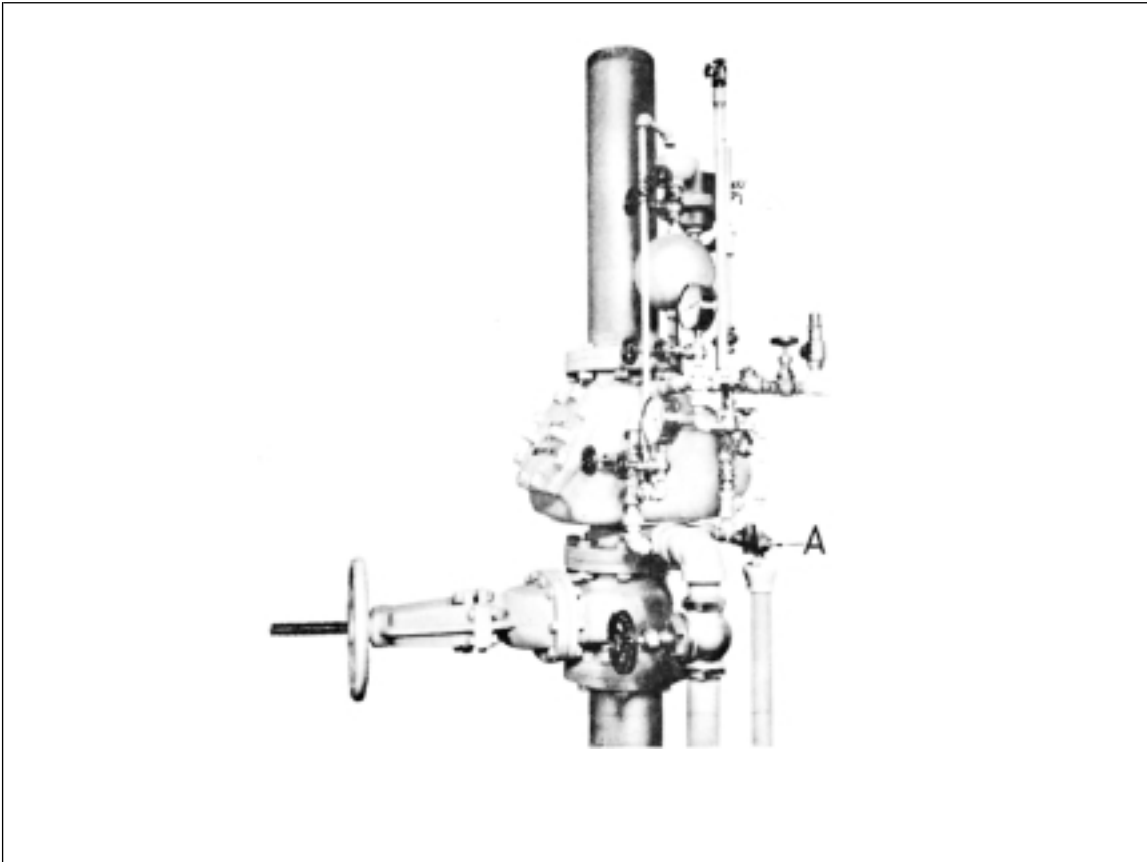

Fig. 80. Reliable Model C, as installed with trim.

Rockwood Models A and B are similar differential dry-pipe valves (Fig. 81). Air pressure exerted on clapper 1 resists water pressure. When system air pressure is reduced sufficiently, water pressure forces clapper 1 open. Clapper 1 is then held open by gravity latch 4.

SETTING

1. Close the main control valve.
2. Open main drain valve A (Fig. 2) and all drawoff valves and vents at low points throughout the system; close them when water ceases to flow.
3. Remove plug 8 and drain; close when finished.
4. Remove cover 7 of the dry valve and carefully clean clapper 1, air seat 2, water seat 3, and rubber diaphragm 5.
5. Raise gravity latch 4 and place clapper 1 on its seats. In the Model B valve, turn releasing device 6 to release clapper 1. Then turn releasing device 6 to the right as far as it will go, closing the opening in the valve body.
6. Replace cover 6 of the dry valve.
7. Open lower priming valve C and upper priming valve B. Open priming valve G and prime the dry valve until water remains in priming chamber E. Close lower priming valve C and upper priming valve B. Open test valve F and allow water to drain; close when water ceases to flow.

*Formerly Rockwood Sprinkler Co.

8. Pump air pressure into the system.

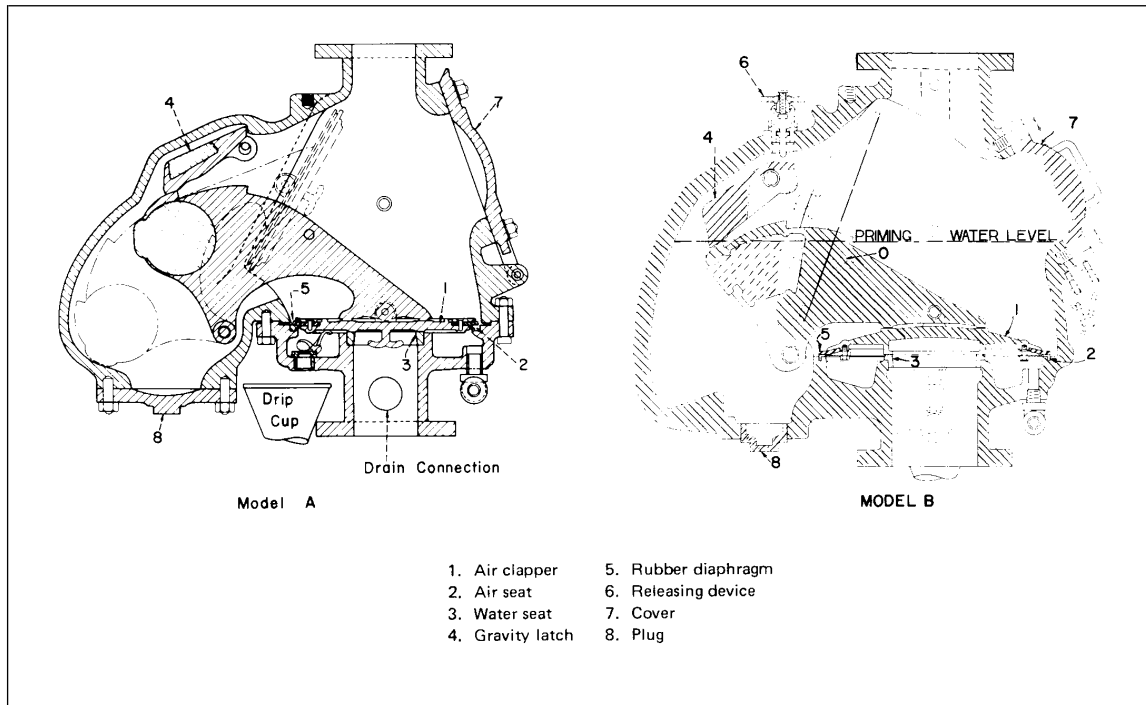

Fig. 81. Rockwood dry-pipe valves, Model A and Model B, internal views.

Table 19

Maximum Water Pressure, (kPa) (bars)	Minimum Air Pressure, (kPa) (bars)	Maximum Air Pressure, (kPa) (bars)
50	15	25
(345) (3.45)	(103) (1.03)	(172) (1.72)
75	20	30
(517) (5.17)	(138) (1.38)	(207) (2.07)
100	25	35
(689) (6.89)	(172) (1.72)	(241) (2.41)
125	30	45
(862) (8.62)	(207) (2.07)	(310) (3.10)
150	35	50
(1034) (10.34)	(241) (2.41)	(345) (3.45)

9. Open wide the main control valve.
10. Check that no leakage appears at the drip valve.
11. Test the water supply by opening main drain valve A.

2.25 Rockwood Model C

Rockwood Model C Dry-Pipe Valve

4 in. (102 mm), 1929 TO 1968

6 in. (152 mm), 1929 TO 1968

8 in. (203 mm), 1934 TO 1968

Firematic Sprinkler Devices Inc., Shrewsbury, Ma.*

DESCRIPTION

The Model C is a differential valve. The air and water clappers 1 are combined into one circular bronze disc. The clapper arm 2 contains a counterweight 3, which assists in opening clapper 1 upon valve operation. There is an automatic drip valve 9 which is held open by clapper 1 when the valve is in set position. As clapper 1 opens, drip valve 9 seats.



Fig. 82. Rockwood dry-pipe valve trim.

OPERATION

When the valve (Fig. 83) is in set position, clapper 1 rests on air seat 4 and water seat 5. System air pressure on clapper 1 resists water pressure at a ratio of 1 pressure unit of air to 5 or 6 pressure units of water.

When system air pressure is reduced sufficiently, water pressure forces clapper 1 open. Clapper 1 is held open by gravity latch 8 engaging latch notches 7 on clapper arm 2.

*Formerly Bliss-Rockwood, and (earlier) Rockwood Sprinkler, Worcester, Mass.

RESETTING

1. Close main control valve supplying water to the system.
2. Open main drain valve B and all draw off valves and vents at low points throughout the system, closing them when water ceases to flow.
3. Remove cover of dry valve and lift clapper 1 onto its third latch notch. Also, remove plug 12.

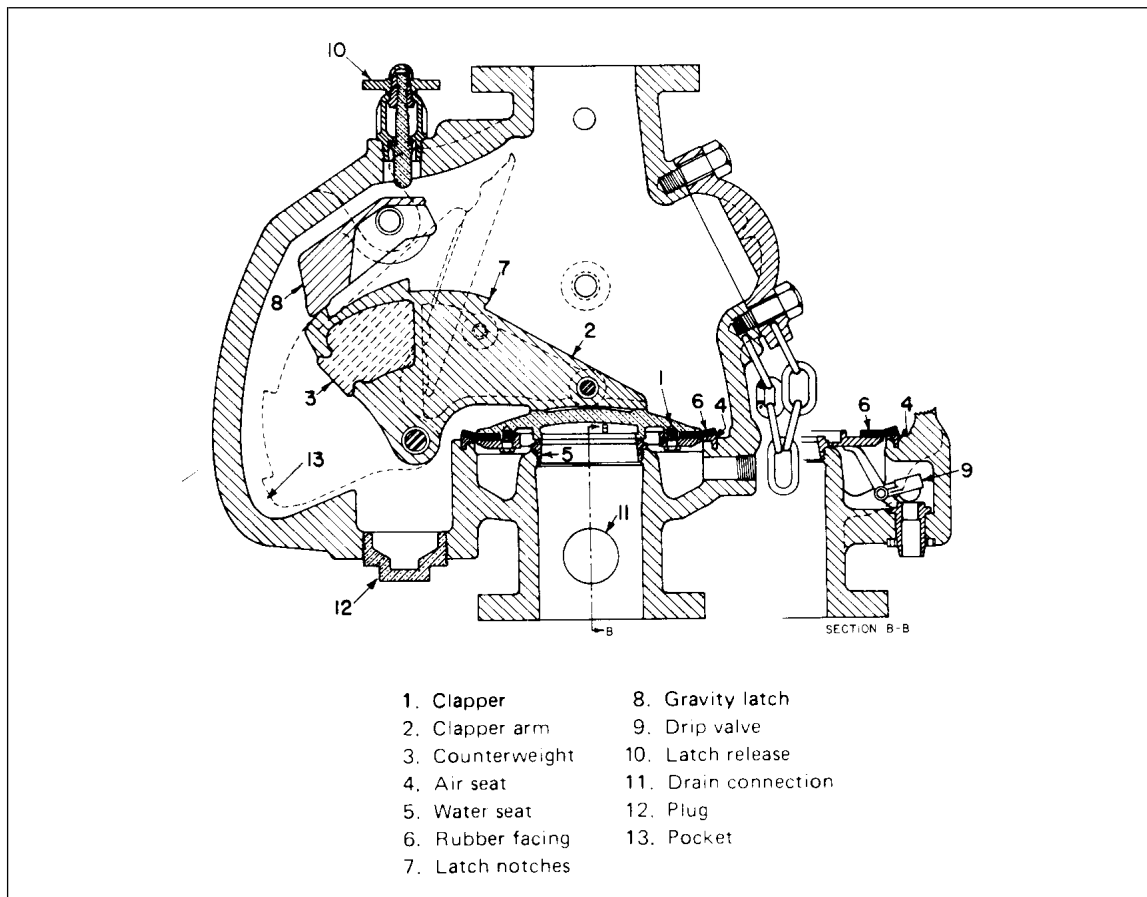

Fig. 83. Rockwood Model C dry-pipe valve.

4. Clean air seat 4, water seat 5, and rubber facing 6, and remove any scale on dry valve wall in pocket 13.
5. To close clapper 1, turn latch release 10 to the right raising gravity latch 8. This allows clapper 1 to be placed on its seat.
6. Turn latch release 10 to the left all the way so as to release gravity latch 8. This also closes the opening in the body of the valve through which the latch release 10 passes.
7. Replace and tighten cover. Replace plug 12.
8. Open upper priming valve C and lower priming valve D. Open valve E and fill dry valve until water remains in priming chamber G. Open test valve F and empty any excess water. Close test valve F and lower priming valve D. Fill the priming chamber G with water and close upper priming valve C when finished.
9. Pump sufficient air into the system to hold the clapper closed against maximum water pressure as indicated in Table 20.
10. Open Main Control Valve.
11. Make sure no leakage appears at drip valve 9.
12. Test water supply by opening drain valve B.

Table 20. System Air/Water Pressure.

Maximum Water Pressure			Air Pressure					
			Not Less Than			Not More Than		
psi	(kPa)	(bars)	psi	(kPa)	(bars)	psi	(kPa)	(bars)
50	(345)	(3.5)	15	(103)	(1.0)	25	(172)	(1.7)

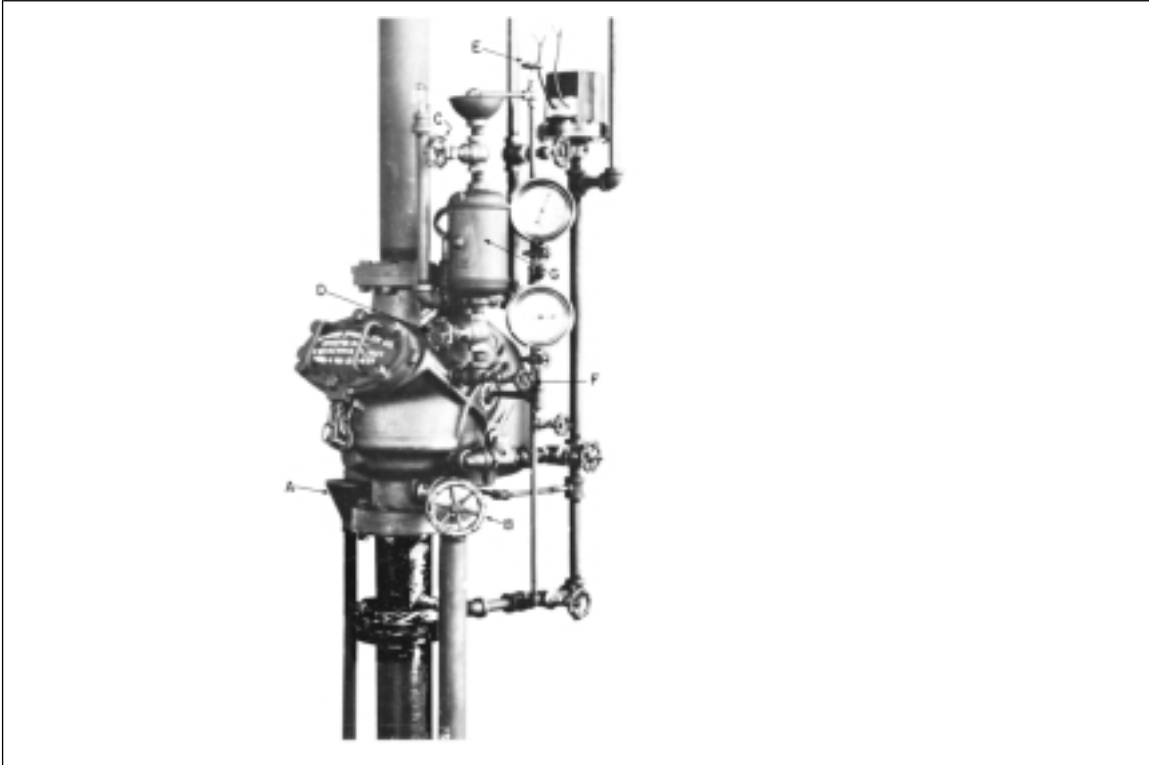

Fig. 84. Rockwood Model C dry-pipe valve, as installed with trim.

75	(517)	(5.2)	20	(138)	(1.4)	30	(207)	(2.1)
100	(689)	(6.9)	25	(172)	(1.7)	35	(241)	(2.4)
125	(862)	(8.6)	30	(207)	(2.1)	45	(310)	(3.1)
150	(1034)	(10.3)	35	(241)	(2.4)	50	(345)	(3.5)

**ROCKWOOD MODEL D, FIREMATIC MODEL D, QUALITY MODEL D,
AND ASTRA MODEL A DRY-PIPE VALVES**

3 in. (76 mm), 1939 TO DATE*
 3½ in. (89 mm), 1931 TO DATE*
 4 in. (102 mm), 1971 TO DATE
 6 in. (152 mm), 1971 TO DATE

Firematic Sprinkler Devices, Inc., Shrewsbury, Ma. 01545
 Quality Sprinkler Devices, Inc., Cherry Valley, Ma. 01611
 Astra Sprinklers Ltd., Sherbrooke, Quebec, Canada

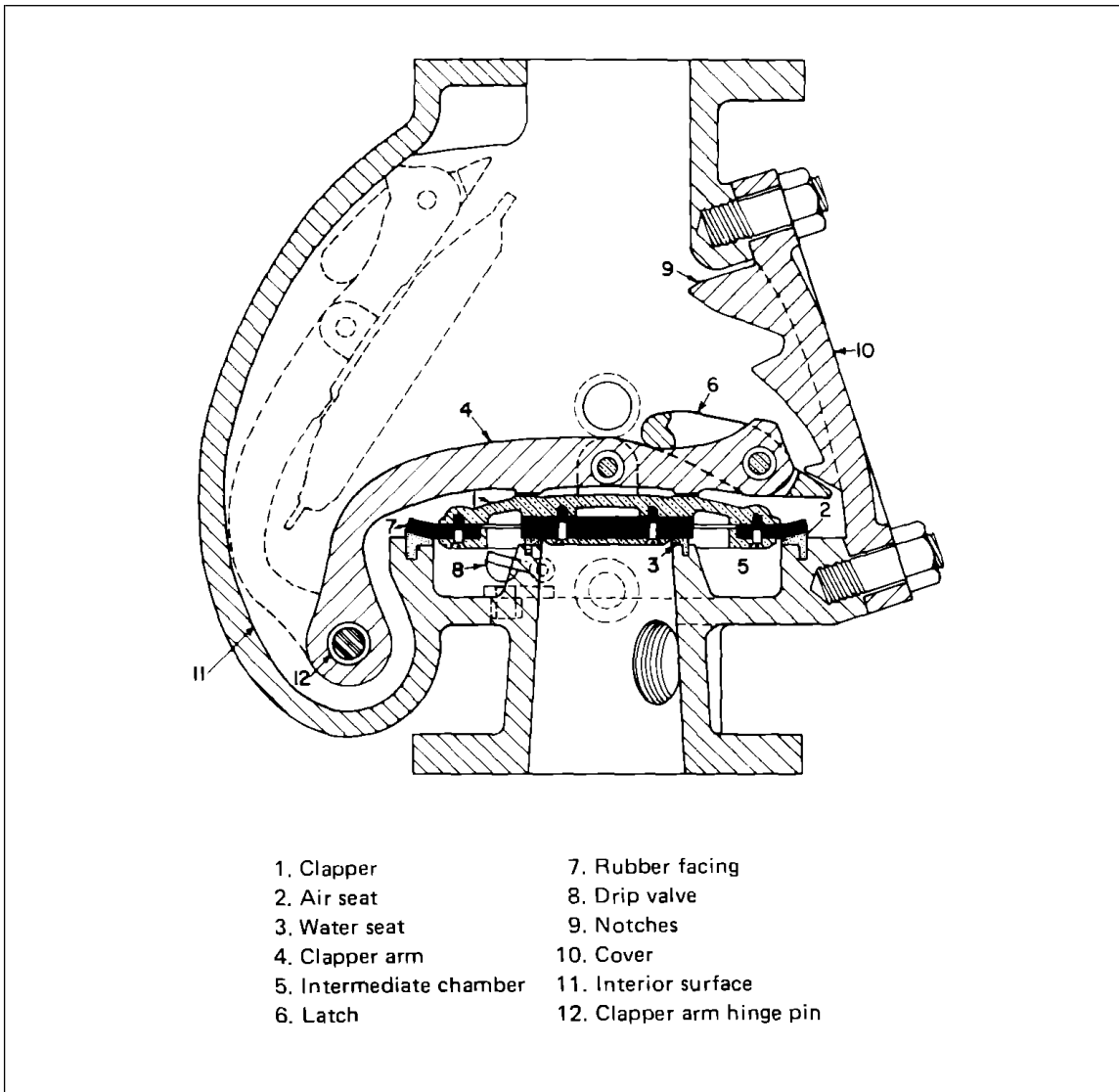

Fig. 85. Rockwood Model D dry-pipe valve.

DESCRIPTION

The Model D is a differential valve (Fig. 85). The air and water clappers are combined into one circular bronze disc. Clapper 1 is carried to the open position by clapper arm 4.

The valve was formerly manufactured as the Rockwood Model D dry-pipe valve. The same valve is currently manufactured by the Firematic, Quality, and Astra companies listed above.

OPERATION

In set position, clapper 1 rests on air seat 2 and water seat 3. System air pressure on clapper 1 resists water pressure at a ratio of one pressure unit of air to 5 or 6 pressure units of water.

When system air pressure is reduced sufficiently, water pressure causes clapper 1 to rise slightly. The intermediate chamber 5 fills with water, destroying the differential and allowing the water pressure to force clapper 1 open. Clapper 1 is then out of the waterway or held open by latch 6 engaging notch 9 on valve cover 10.

RESETTING

1. Close main control valve supplying water to the system.
2. Open main drain valve B (Fig. 86) and all draw-off valves and vents at low points throughout the system, closing them when water ceases to flow.

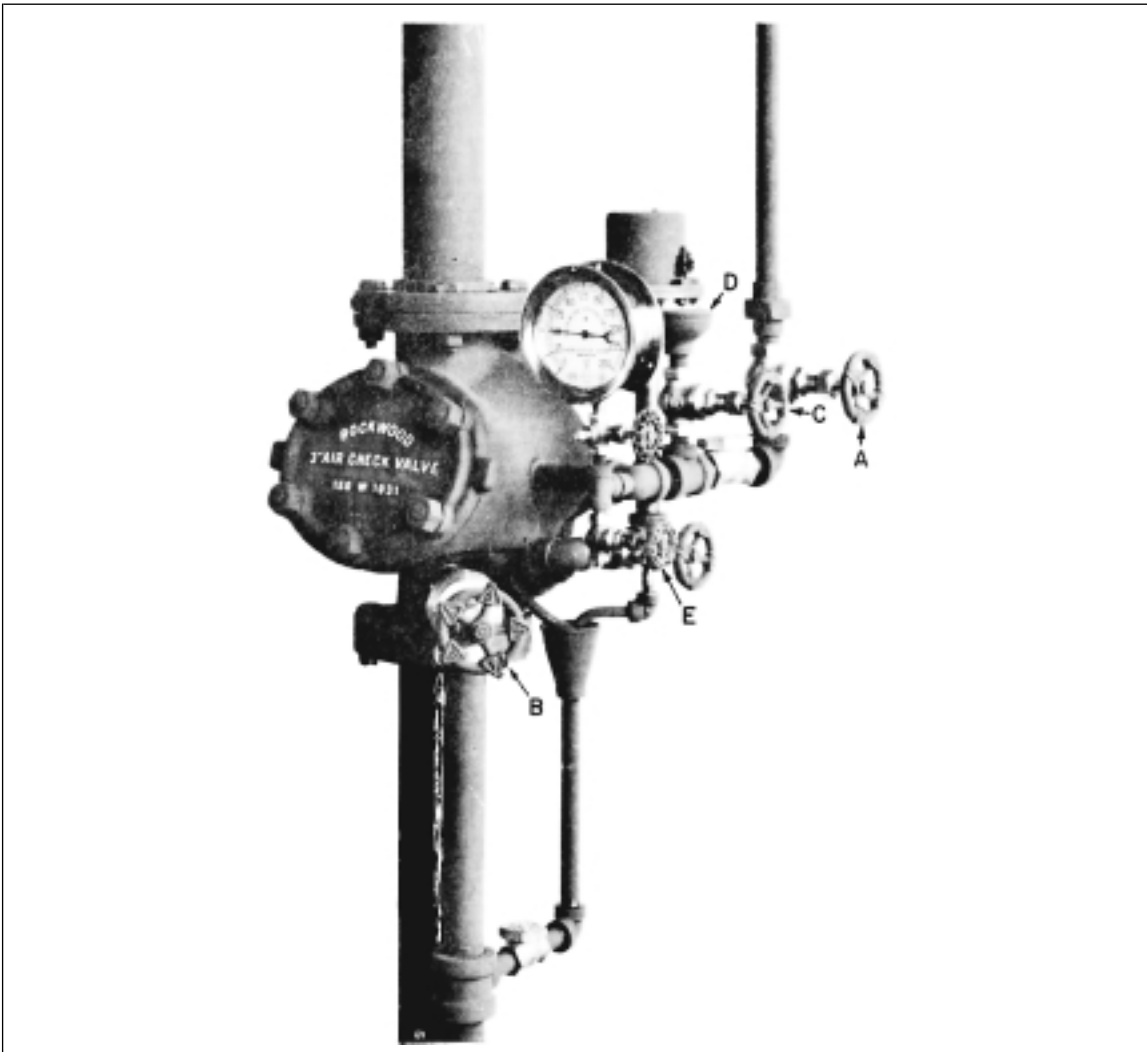

Fig. 86. Rockwood Model D dry-pipe valve, as installed with trim.

3. Remove the cover. Check latch 6 for free movement on its hinge pin, then raise clapper 1 off its seat.
4. Carefully clean intermediate chamber 5, air seat 2, water seat 3, and rubber facing 7. Check clapper 1 for free movement on its hinge pin.
5. Lower clapper 1 onto its seats and clean any scale off interior surface 11 of the valve, paying particular attention to that section behind clapper arm 4 and clapper arm hinge pin 12.

6. Replace cover of dry valve.
7. Open priming valve C and add water through priming cup D to level of test valve E. Close priming valve C, and test valve E.

*Formerly known as Model A air check valve.

8. Open air supply valve A and pump sufficient air into the system to hold the clapper closed against maximum water pressure as indicated in Table 21.

Table 21. System Air/Water Pressure.

Maximum Water Pressure			Air Pressure					
			Not Less Than			Not More Than		
psi	(kPa)	(bars)	psi	(kPa)	(bars)	psi	(kPa)	(bars)
50	(345)	(3.5)	15	(103)	(1.0)	25	(172)	(1.7)
75	(517)	(5.2)	20	(138)	(1.4)	30	(207)	(2.1)
100	(689)	(6.9)	25	(172)	(1.7)	35	(241)	(2.4)
125	(862)	(8.6)	30	(207)	(2.1)	45	(310)	(3.1)
150	(1034)	(10.3)	35	(241)	(2.4)	50	(345)	(3.5)

9. Open main control valve. (Open slowly to avoid raising clapper and tripping the valve.)
10. Check to make sure there is no leakage at drip valve 8.
11. Test water supply by opening drain valve B.

2.26 Standard Model A

Standard Dry-Pipe Valve

MODEL A, 6-INCH 1965

Standard Fire Protection Equipment Co., Charlotte, N.C.

DESCRIPTION

The Standard 6-in. Model A dry pipe valve (Fig. 87) is of the differential type, having a single clapper which consists of these parts: clapper arm (3), clamping ring (5), anti-reset latch (8), rubber water seat (20), and rubber air seat (21).

OPERATION

When the valve is in a normal set position, the clapper rests on the water and air seat ring. Priming water on top of the clapper helps to seal the air seat and also to preserve rubber facings. System air pressure applied on top of the air clapper resists water pressure acting underneath to hold clapper on the seat rings at a ratio of 1 psi air pressure to 5.0 to 6.5 psi water pressure. When the system air pressure is reduced by the opening of one or more sprinklers, this differential is destroyed and water pressure acting under the clapper will force the clapper to open.

SETTING

1. Close valve controlling water supply to the system.
2. Open main drain valve; also open all draw-off valves and vents at low points throughout the system, closing them when water has ceased to flow.
3. Remove hand hole cover of dry pipe valve (Fig. 87) and swing clapper and clapper arm assembly outward. Then carefully clean the rubber clapper facing, air-seat ring, and water seat ring (Fig. 87, 6 and 7).
4. Raise clapper latch (Fig. 87, 8) and swing clapper assembly forward and downward to a closed position.
5. Replace rubber hand hole cover gasket and tighten cover stud nuts.

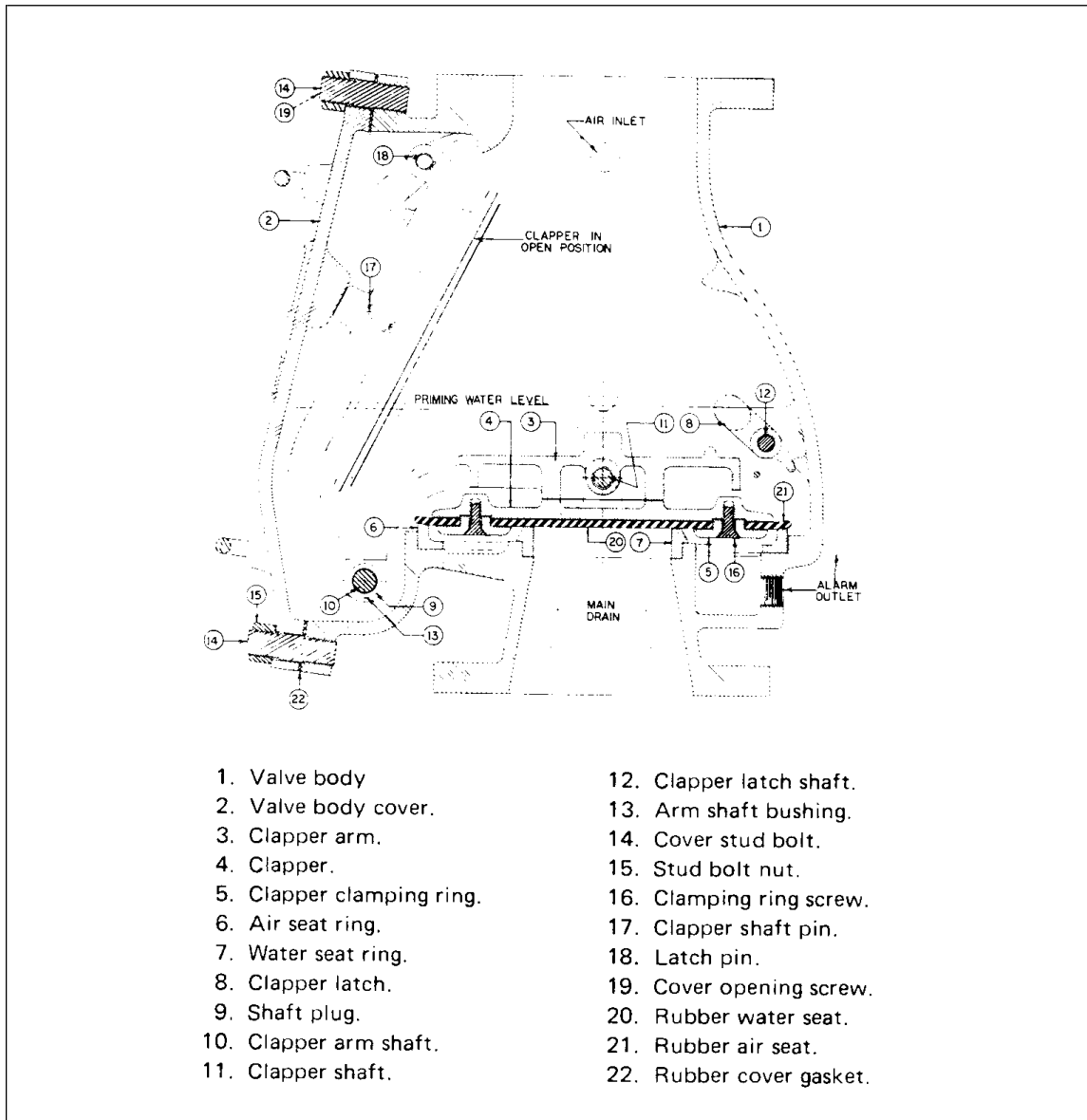

Fig. 87. Standard Dry Pipe Valve, Model A.

6. Open globe valves (Fig. 88, 1 and 2) above and below priming chamber and fill body of dry pipe valve with water through priming cup (Fig. 88, 3) until water remains in cup. Then close the valves above and below the priming chamber tightly, leaving priming chamber filled with water. Remove cap (Fig. 88, 4) from nipple extending into top of drain collector and open 1/4-in. valve (Fig. 88, 5) until water ceases to flow into collector. Priming water in dry pipe valve will now be at its proper level. The 1/4-in. valve can be closed now and pipe cap replaced.

7. Open primary air supply valve (Fig. 88, 6) and pump a few pounds of air into sprinkler system.

8. Open separately the drain valves and vents at system's low points to force out any accumulation of water. Close them when water ceases to flow.

9. Open primary air supply valve (Fig. 88, 6) and allow sufficient air pressure into the system to hold dry pipe valve clapper assembly in a closed position against the maximum water pressure in accordance with the following table:

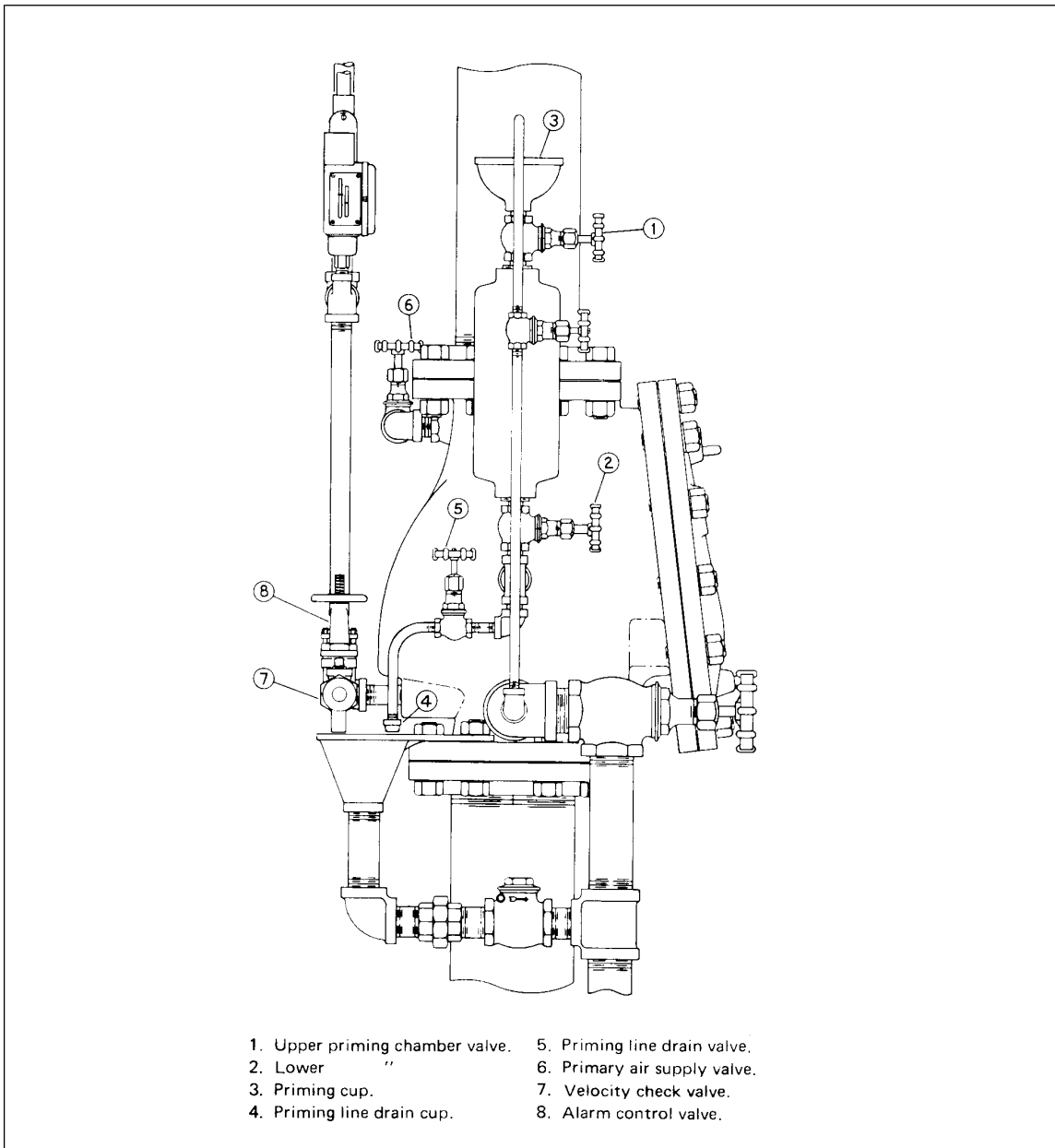

Fig. 88. Side View of Standard Model A dry pipe valve as installed with various trimmings.

Table 22

Maximum Water Pressure	Air Pressure	
	Minimum	Maximum
Below 50	15	—
50	15	25
75	20	30
100	25	35
125	30	45
150	35	50

10. Permit air pressure to stand for a few moments; then inspect velocity check valve (Fig. 88, 7); if no leak occurs, the dry pipe valve's air seat is correctly seated, and valve (Fig. 88,6) must be tightly closed.

11. Open alarm control valve (Fig. 88, 8) and close alarm test valve. It is important that the valve (Fig. 88, 8) remain in a normally open position to allow proper operation of alarm devices.
12. Slightly open valve controlling water supply and check for water leaks from velocity check valve (Fig. 88, 7); if no leakage occurs, air seat and water seat are correctly seated and MAIN CONTROL VALVE MUST BE OPENED FULLY.
13. System is now in service. Water pressure should be indicated on the lower gauge and air pressure on the upper gauge. (These gauges do not appear on Fig. 88.) If there is no indication of pressure, open the valve directly below the air pressure gauge.

2.27 Star Model A

Star Dry Pipe Valve

MODEL A 6 IN., 1924 TO 1930

Star Sprinkler Corp., Philadelphia, Pa.

DESCRIPTION

The Star Model A dry-pipe valve* is a differential type valve with air and water clappers being carried on one hinge. Both air and water seats are set on an angle of 60° with the axis of the valve. The waterway tapers from 6 in. at the inlet to 5 in. at the seat ring.

OPERATION

When air pressure in the overhead system is reduced by the operation of the sprinkler, the water pressure under the water clapper raises the hinge clapper, allowing the trip latch to fall forward against the water seat nozzle, closing the drip valve.

SETTING

Refer to Figure 89, (a) and (b).

1. Close valve controlling water supply to dry-pipe valve.
2. Open main drain valve (18) and all other drain valves and vents at low points throughout the system. Close when flow of water has stopped.
3. Remove handhole cover (2). Carefully clean rubber air valve (5), air seat (8), water clapper (4), and water seat nozzle (7).
4. Swing hinged clapper carrier (3) so that the rubber air valve (5) and water clapper (4) are nearly on their seats. Raise the trip latch (10) by pushing up on drip valve (11), so that the clappers will rest on their seats.
5. Replace handhole cover (2) and gasket.
6. Open valves 23, 24, and 26. Put water into the dry-pipe valve through the filling cup (31) until water flows from test valve 26. Close test valve 26 after water stops flowing. Close valves 23 and 24.
7. Open valve 27 long enough to pump a few pounds of air into the sprinkler system.
8. Open separately drain valves and vents located at low points of the system to force out any accumulated water. Close them when flow stops.

Table 23.

Water Pressure, (lb)	Air Pressure, (lb)	
	Not Less Than	Not More Than
50	15	25
75	20	30
100	25	35
125	30	45
150	35	50

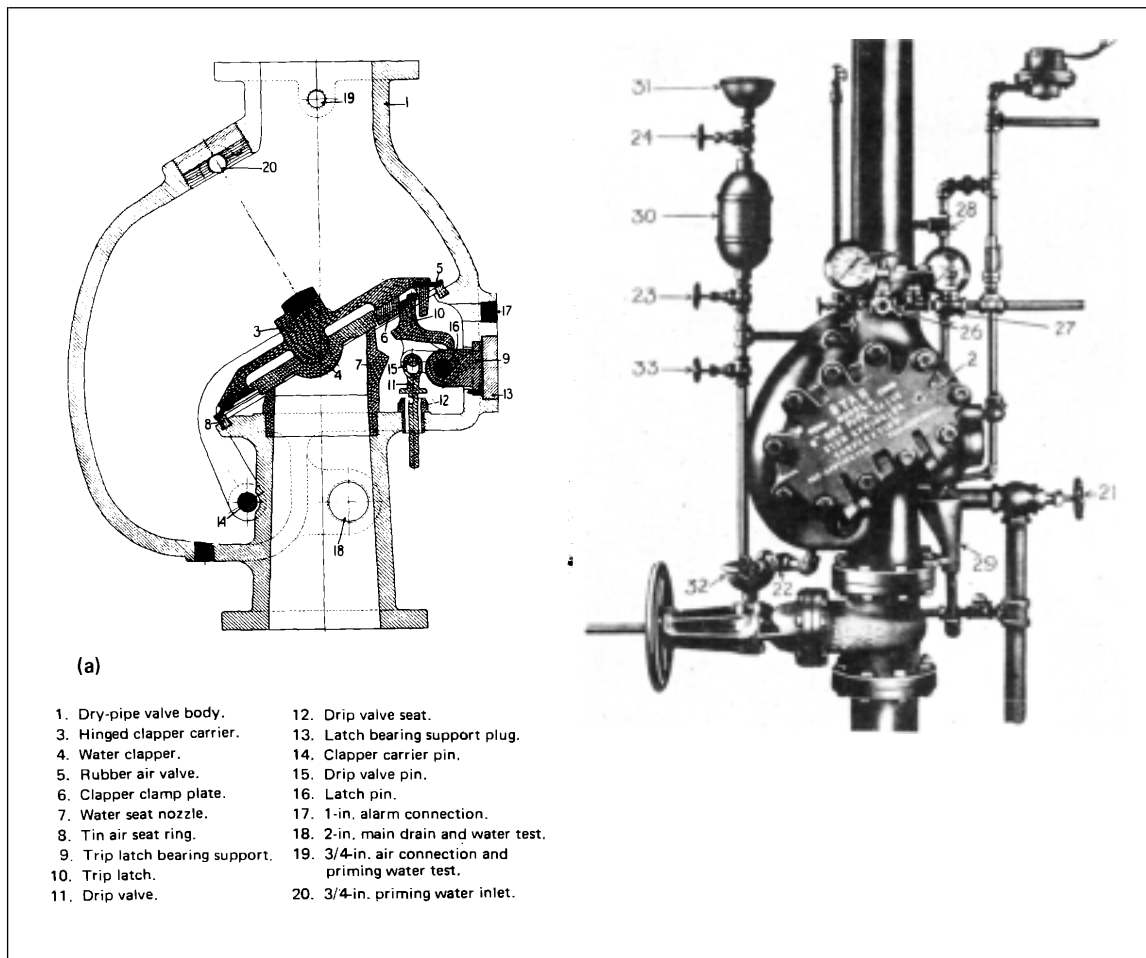

Fig. 89. Star Model A dry-pipe valve. (a) cross section of valve. (b) valve as installed with trim.

9. Open valve 27 and pump sufficient air into the sprinkler system to hold the dry-pipe valve in the closed position against the maximum water pressure in accordance with Table 23. Close valve 27.

10. Observe if water flows out drip valve (11). If the air seat is tight, there will be no water flowing.

11. Slowly open valve controlling water supply to the dry-pipe valve. Observe if water flows out drip valve (11). If the water and air seats are tight, there will be no water flowing.

12. Open wide valve controlling water supply and lock in the open position.

*This valve was formerly Secorp Model A (1910-1924), manufactured by Sprinkler Equipment Corp., Philadelphia, Pa.

STAR DRY PIPE VALVE

MODEL B 6 IN., 1930 TO 1933

MODEL C 6 IN., 1933 TO 1968

MODEL C 4 IN., 1940 TO 1968

Note: The Model C 4-in. dry-pipe valve was manufactured for Firematic Sprinkler Device, Inc. and labeled Rockwood Model C-1 4 in.

DESCRIPTION

The Star Model B dry-pipe valve is a semi-mechanical type of valve, having separate air (3, in Fig. 90) and water (5 in Fig. 90) clappers which are connected by a link. The Model B has a tapered waterway. Through the opening in the front, the seat may be cleaned, valves set, rubber facing replaced, and if necessary, the clapper can be removed.

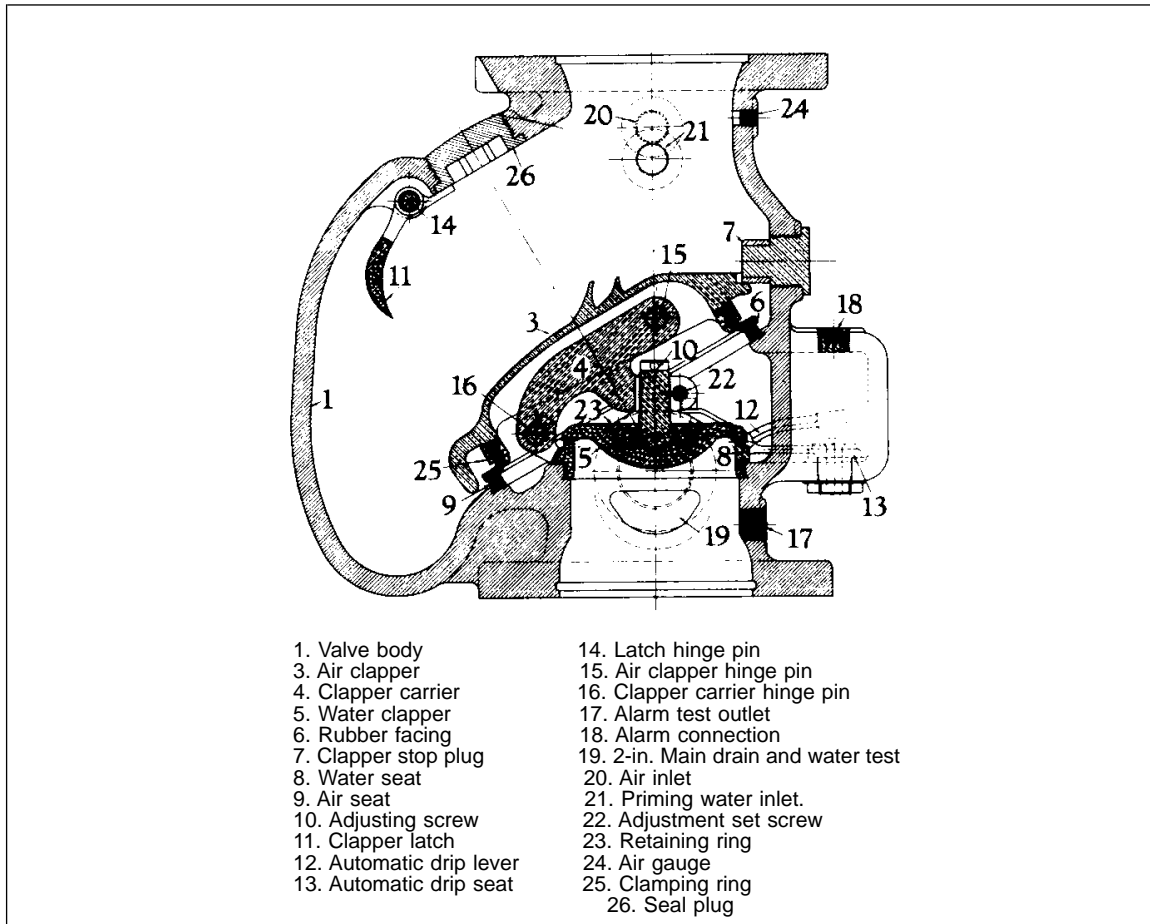

Fig. 90. Star Model B (and C) dry-pipe valve

Star Model C is the same as Model B except for the following changes:

1. Method for fastening the rubber facing, (6 in Fig. 90) (four bronze machine screws).
2. Air seat (9, in Fig. 90) has been lowered and made $\frac{3}{16}$ in. wide ($\frac{7}{16}$ in. on Model B).
3. The ball drip has been lowered.

OPERATION

When the system's air pressure is reduced, the air pressure in the differential chamber of the valve body releases the clapper on the air seat, the service pressure raises the clapper and clapper carrier, this in turn raises the air clapper from its seat, and the flow of water through inlets carries water and air clapper assembly

upwards and backwards out of the waterway, where it is automatically secured by the clapper latch. The upward movement of the clappers closes the drip outlet, and supply water flows through the dry-pipe valve to sprinkler system piping.

SETTING

Refer to Figures 91, 92 and 93.

1. Close valve controlling water supply to dry-pipe valve.
2. Open main drain valve (A) and all other drain valves and vents at low points throughout the system. Close when flow of water has stopped.
3. Remove valve cover (2). Carefully clean rubber facing (6), air seat (9), water clapper (5), and water seat (8).
4. Lift clapper latch (11) and draw the clappers (3 and 5) down to their seats.
5. Replace valve cover (2) and gasket.
6. Open valves B and C with valve F closed. Put water into the dry-pipe valve through priming cup (28) until water remains in the priming cup. Close valves B and C and open drain valve F. Close valve F after water stops flowing.
7. Open air supply valve E long enough to pump a few pounds of air into the sprinkler system.

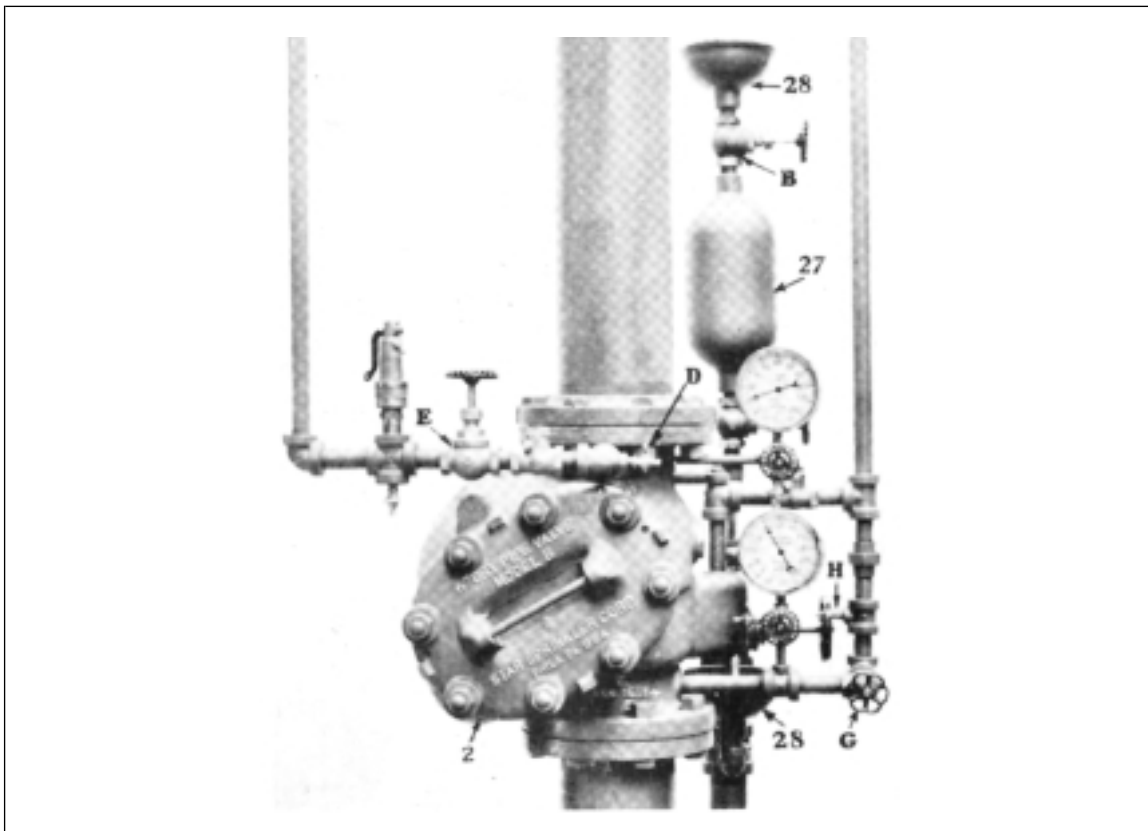

Fig. 91. Star Model B (and C) dry-pipe valve

8. Open separately drain valves and vents located at low points of the system to force out any accumulated water. Close them when flow stops.

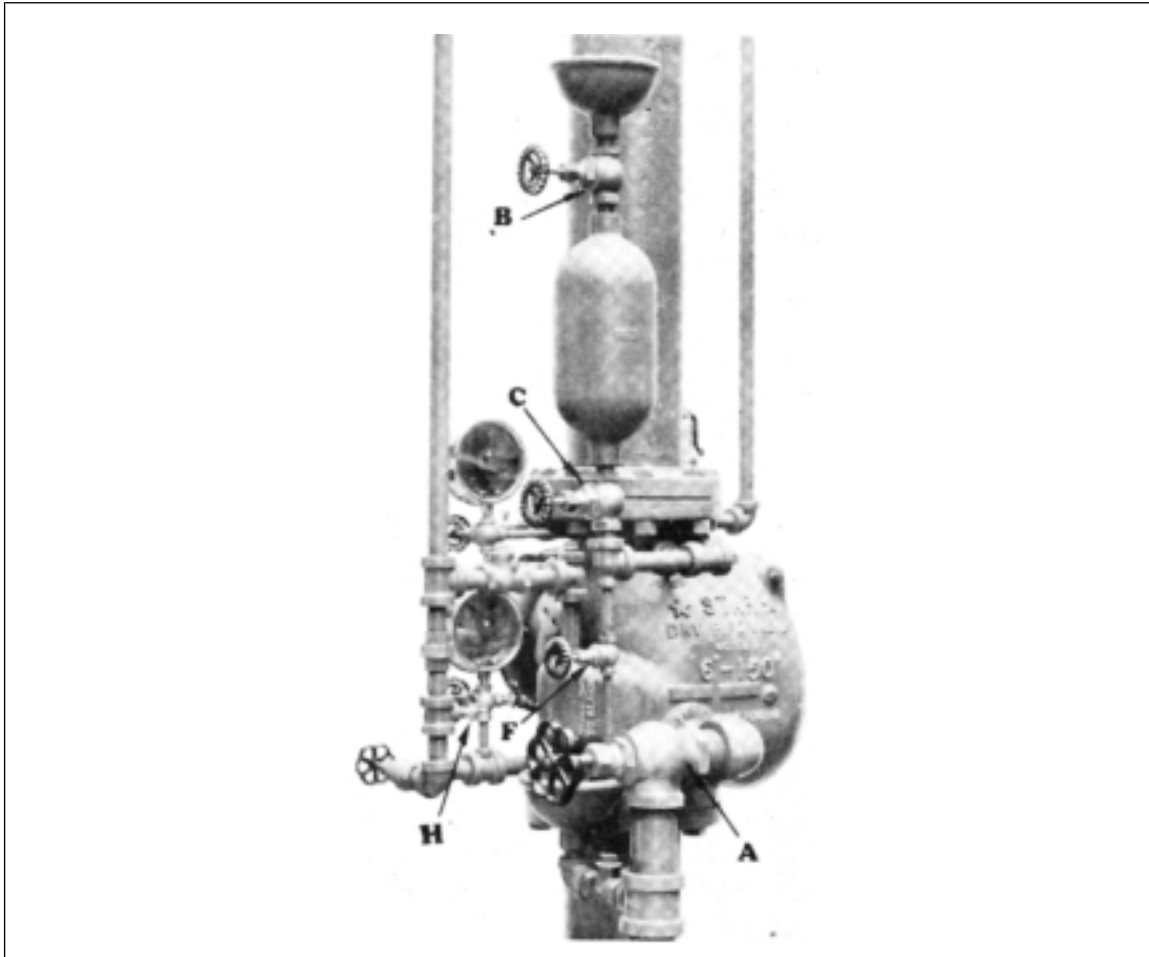

Fig. 92. Star Model B (and C) dry-pipe valve

9. Open air supply valve E and pump sufficient air into the sprinkler system to hold the dry-pipe valve in the closed position against the maximum water pressure in accordance with Table 24.
10. Observe if water flows out the automatic drip seat (13). If air seat is tight, there will be no water flowing.
11. Slowly open valve controlling water supply to the drypipe valve. Observe if water flows out the automatic drip seat (13). If water and air seats are tight, there will be no water flowing.

Table 24.

Water Pressure, (lb) maximum	Air Pressure, (lb)	
	Not Less Than	Not More Than
50	15	25
75	20	30
100	25	35
125	30	45
150	35	50

2.28 Star Model D

Star Dry-Pipe Valve Model D 3-Inch

1949-TO-DATE

Star Sprinkler Corporation, Philadelphia, Pennsylvania

DESCRIPTION

The Star 3-in. Model D dry-pipe valve (Fig. 93) is of the type in which practically all of the difference in the water and air pressure is obtained by the multiplying action of a retaining lever (6). In the closed position, a double seated swing clapper (3) is held on its seats by the retaining lever, the other end of which rests against a plunger (17) extending into the valve body at right angles to the axis of the valve. The plunger is held against the retaining lever by a differential valve disc (16) operated by the air pressure in the sprinkler system.

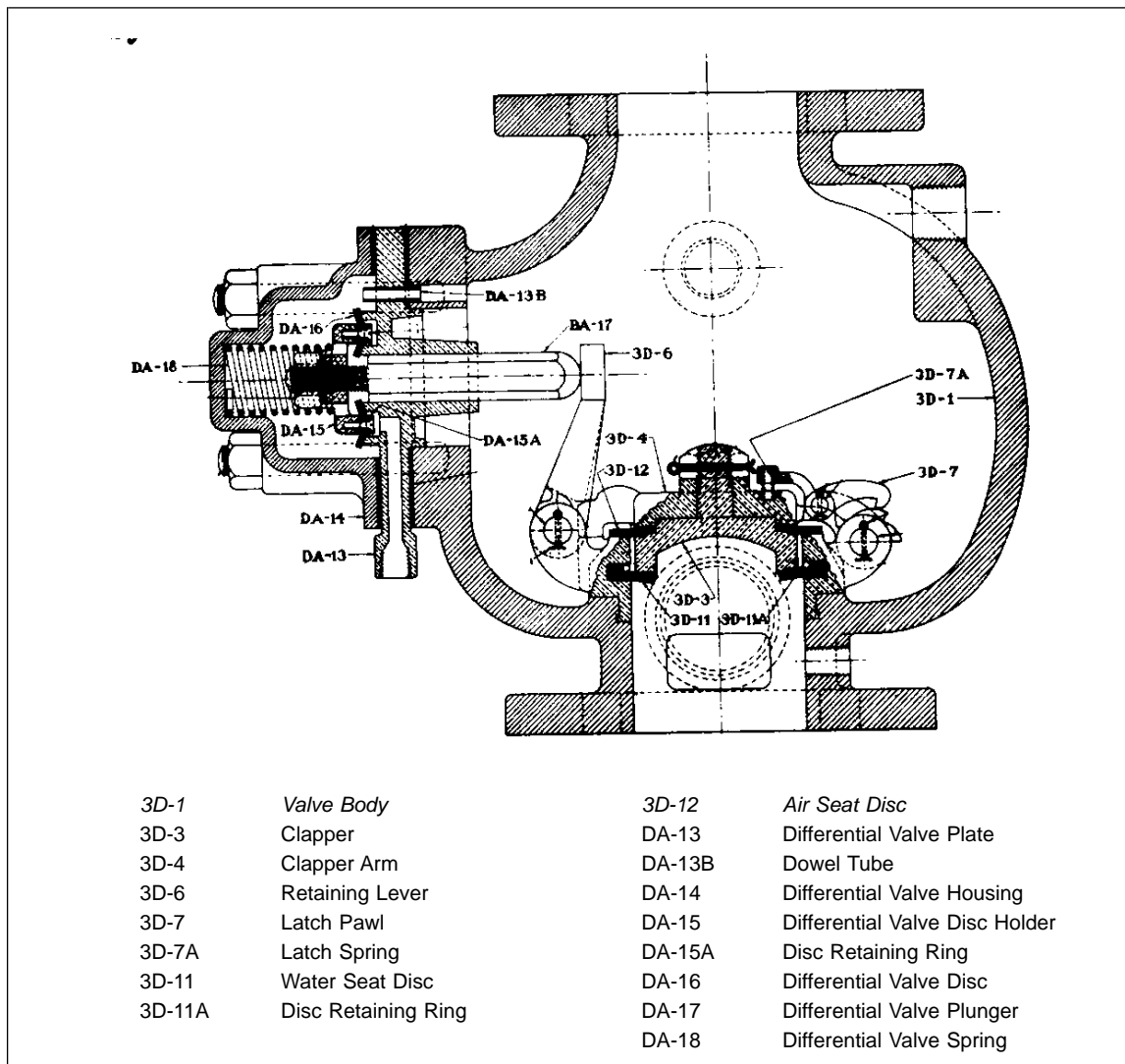

Fig. 93. Closed (Set Dry) Position of Parts.

When the valve is set, the main clapper rests on a soft rubber facing (11) which projects into the inlet waterway. At the top of the main clapper is another soft rubber facing (12) which rests on the top of the inlet waterway thus providing a seal against system air pressure. The space between the water and air seats is vented

to atmosphere through a ball-check drain valve and an alarm connection. In this way an intermediate chamber is provided to take care of possible leakage past either the water or air seat, although this is primarily a mechanical type dry-pipe valve.

The differential valve, which is the primary tripping device, consists of a housing (14) open to system air pressure, which encloses a spring loaded, rubber faced disc (16) covering an annular groove in the seat. This groove is vented to atmosphere

Latch points, to prevent reseating of the valve after it has opened, are provided by projections on the hinge-pin guide which a spring-loaded latch (7) on the clapper can engage.

OPERATION

When the valve is set, the force of the water pressure on the clapper (3) is transmitted through the retaining lever (6) to the plunger (17). This force is resisted by the spring (18), plus the system air pressure acting on the area of the grooved seat of the differential valve. The spring force is not sufficient, of itself, to overcome the thrust of the plunger. When a sprinkler opens and the air pressure falls, a point is reached where the disc (16) of the differential valve is forced of its seat. This action permits the plunger to move back and the retaining lever to rotate freeing the main clapper. Water pressure then throws the clapper open. Reseating is prevented by the engagement of the latch (7) with projections on the hinge-pin guide.

DIRECTIONS FOR RESETTING

To set the dry-pipe valve, close the main control valve, drain the system, remove the cover, and thoroughly clean the rubber facings of the clapper (3) and the seat rings. The differential valve housing (14) is also removed and the valve disc (16) and seat ring is wiped clean. Make sure that the plunger (17) can be moved freely by hand into the valve plate (13). Next the differential valve disc is placed on its seat, the spring (18) and housing (14) replaced, and the housing bolted tightly to the valve body. The latch (7) is disengaged and the clapper lowered to the closed position. Take care that the end of the retaining lever (6) bears fully on the clapper arm (4). The cover plate is then bolted in place and priming water is admitted through the priming chamber (Fig. 2). Finally, air is pumped into the system to the pressure indicated in the table at right.

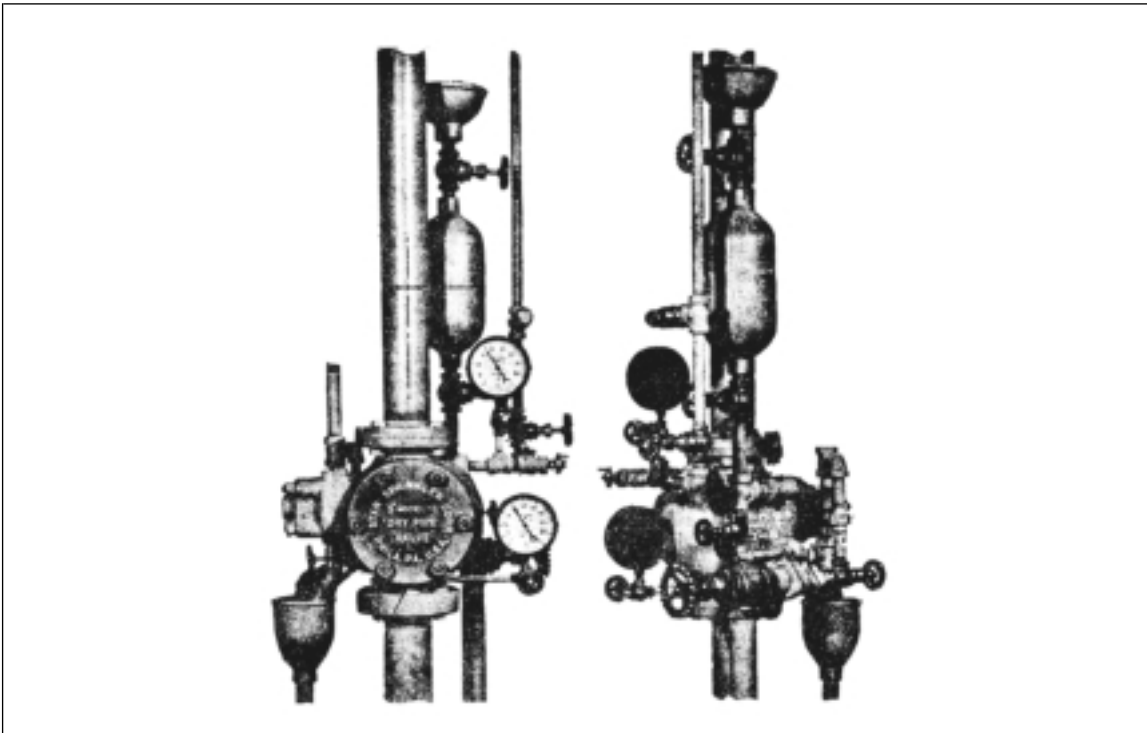

Fig. 94. Front and Rear Views.

Table 25

Highest Service Water Pressure or Fire Pump Pressure	Air Pressure	
	Not Less Than	Not More Than
50	15	25
75	20	30
100	25	35
125	30	45
150	35	50

As the air pressure builds up in the system, the force on the grooved seat on the differential valve increases moving the plunger forward against the retaining lever. After the system has been placed on air, the main control valve is opened.

Water leakage by either the air or water seat can be detected at the automatic drip (Fig. 94).

2.29 Viking Models C, C-2, C-3, and D-1

Viking Dry-Pipe Valves

MODEL C, 3-, 4-, 8-IN. (76-, 102-, 203-MM), 1936 TO 1959
MODEL C-2, 3-, 4-, 8-IN. (76-, 102-, 203-MM), 1959 TO DATE
6-IN. (152-MM), 1959 TO 1971
MODEL C-3, 6-IN. (152-MM), 1971 TO 1975
MODEL D-1, 6-IN. (152-MM), 1975 TO DATE

The Viking Corp., Hastings, Michigan

DESCRIPTION

These valves are all similar in design (Fig. 95). They differ from the usual dry-pipe valve in that the differential is obtained by means of a large annular casting supported by a rubber diaphragm held horizontally between the two parts of the body of the valve. A single swing clapper, hinged to the annular casting, covers the water seat in the body of the valve and also an air seat on the annular casting. When the valve is set, a setting latch (hinged to the annular casting) engages with a projection on the clapper arm in such a manner that the clapper in the annular casting acts as a unit forming a large area on which the air pressure is exerted. The water pressure acts only on the underside of the swing clapper.

When the system pressure is lowered to the trip point of the valve, an upward movement of the clapper and annular casting unit is allowed by the rubber diaphragm until a projection on the hub of the latch strikes a stop, causing the latch to rotate and disengage from the clapper arm. The water pressure then lifts a swing clapper and water flows into the sprinkler system.

RESETTING

1. Close system water control valve and open main and auxiliary drains.
2. When water ceases to run from the main drain, open handhole cover and examine seat to make sure it is free of any foreign matter. Do not put grease or any other substance on the seat.
3. Unlatch the clapper and pull down to seat. Insert wrench handle through hole in guard and lift until pawl latches.
4. Add priming water to level of handhole and replace handhole cover.
5. Close all auxiliary drains.
6. Build up air pressure as shown in table.

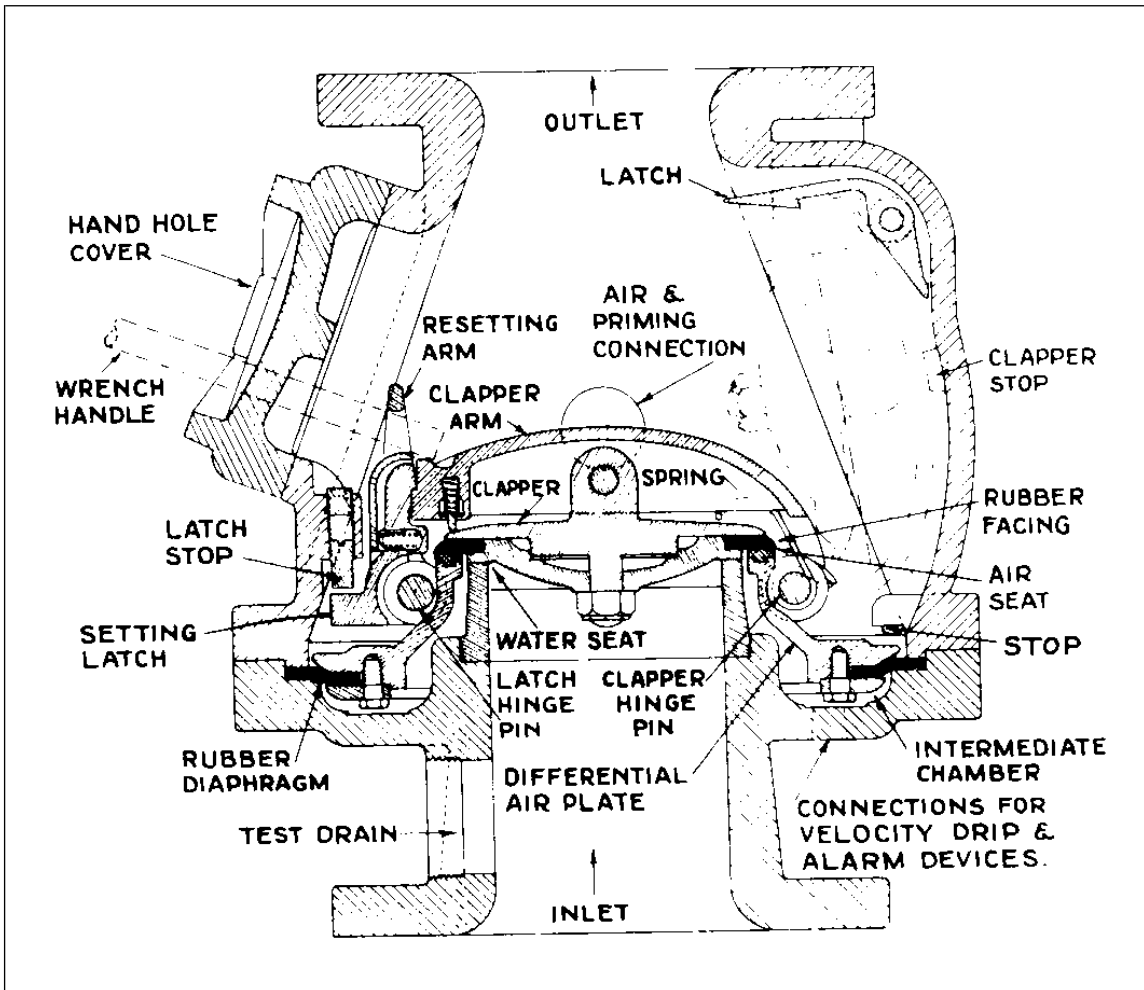

Fig. 95. Viking dry-pipe valve. Note: There are three stops, not readily seen through the small hand hole, that must be felt to determine if they are intact. If they are not, valve will not operate.

Table 26

Water Pressure			Air Pressure					
Maximum			Minimum			Maximum		
psi	(kPa)	(b)	psi	(kPa)	(b)	psi	(kPa)	(b)
50	(345)	(3.45)	15	(103)	(1)	25	(172)	(1.7)
75	(517)	(5.17)	20	(138)	(1.4)	30	(207)	(2.1)
100	(689)	(6.89)	25	(172)	(1.7)	35	(241)	(2.4)
125	(862)	(8.62)	30	(207)	(2.1)	45	(310)	(3.1)
150	(1034)	(10.34)	35	(241)	(2.4)	50	(345)	(3.5)

7. Open water control valve slowly until water pressure has reached maximum, then open control valve completely and lock. Close main drain.

VIKING TYDEN DRY-PIPE VALVE
MODEL A, 6-IN. (152-MM), 1923 to 1930
MODEL A, 4-IN. (102-MM), 1923 to 1933
MODEL B, 6-IN. (152-MM), 1930 to 1935
MODEL B, 4-IN. (102-MM), 1933 to 1936

The Viking Corporation, Hastings, Michigan

DESCRIPTION

The Viking Tyden Models A and B dry-pipe valves (Fig. 96) are differential dry-pipe valves and are similar in construction. In the Model B valve, which is the later design, the clapper is held from reseating by a latch, and a new method is used for attaching the rubber facing. The Model A and B valves are alike in that the air and water clappers are combined in one circular bronze plate. The clapper arm is counterweighted, so that it overbalances the clapper. The Model A valve is made in the 4-inch size, having a venturi throat tapering to 3½-inch at the seat, and the Model B valve is made in the 6-inch size, having a venturi throat tapering to 5-inch at the water seat. The outlet ends are full size.

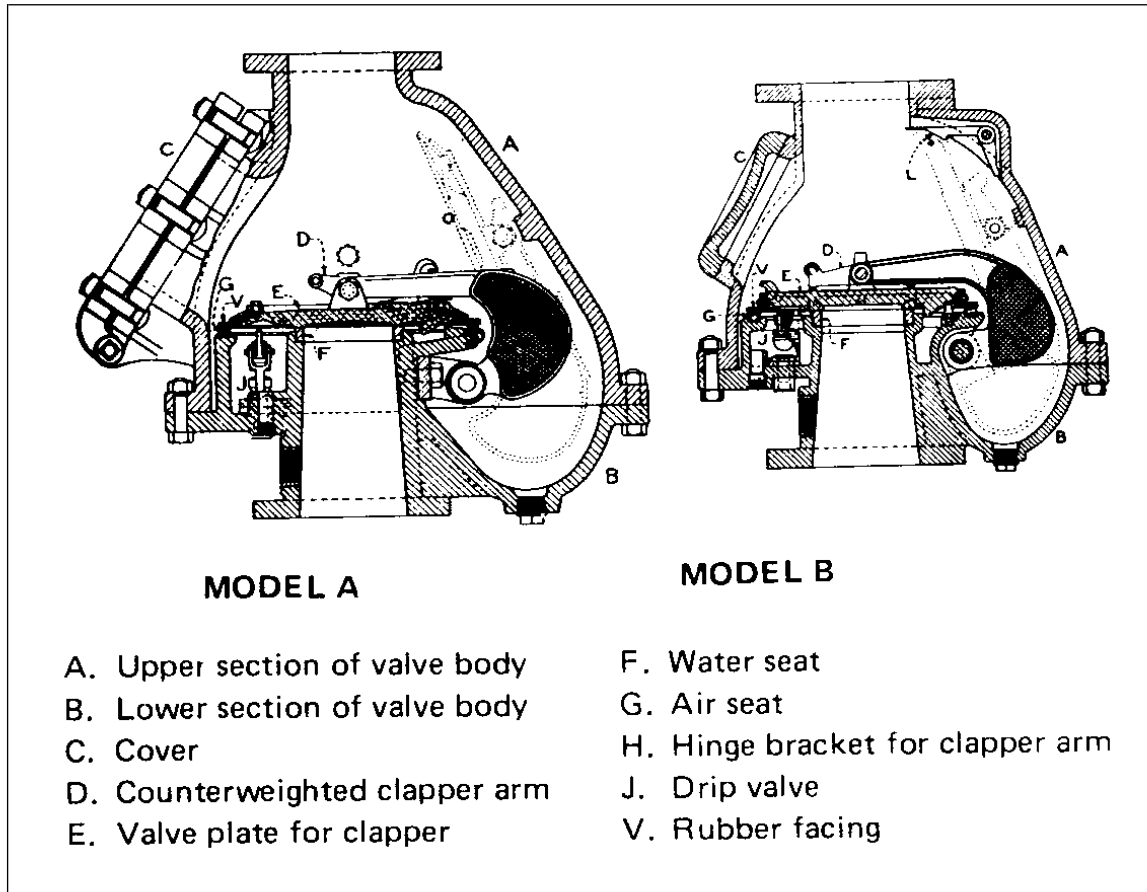

Fig. 96. Viking Tyden Models A and B dry-pipe valves.

RESETTING

1. To set the valve, close drain valve N (Fig. 97) and admit priming water into the valve by slowly opening main valve K until water is at level with the bottom of the hand-hole opening. Then close main gate valve K. Priming water may also be introduced by pouring through the opening in the valve body.

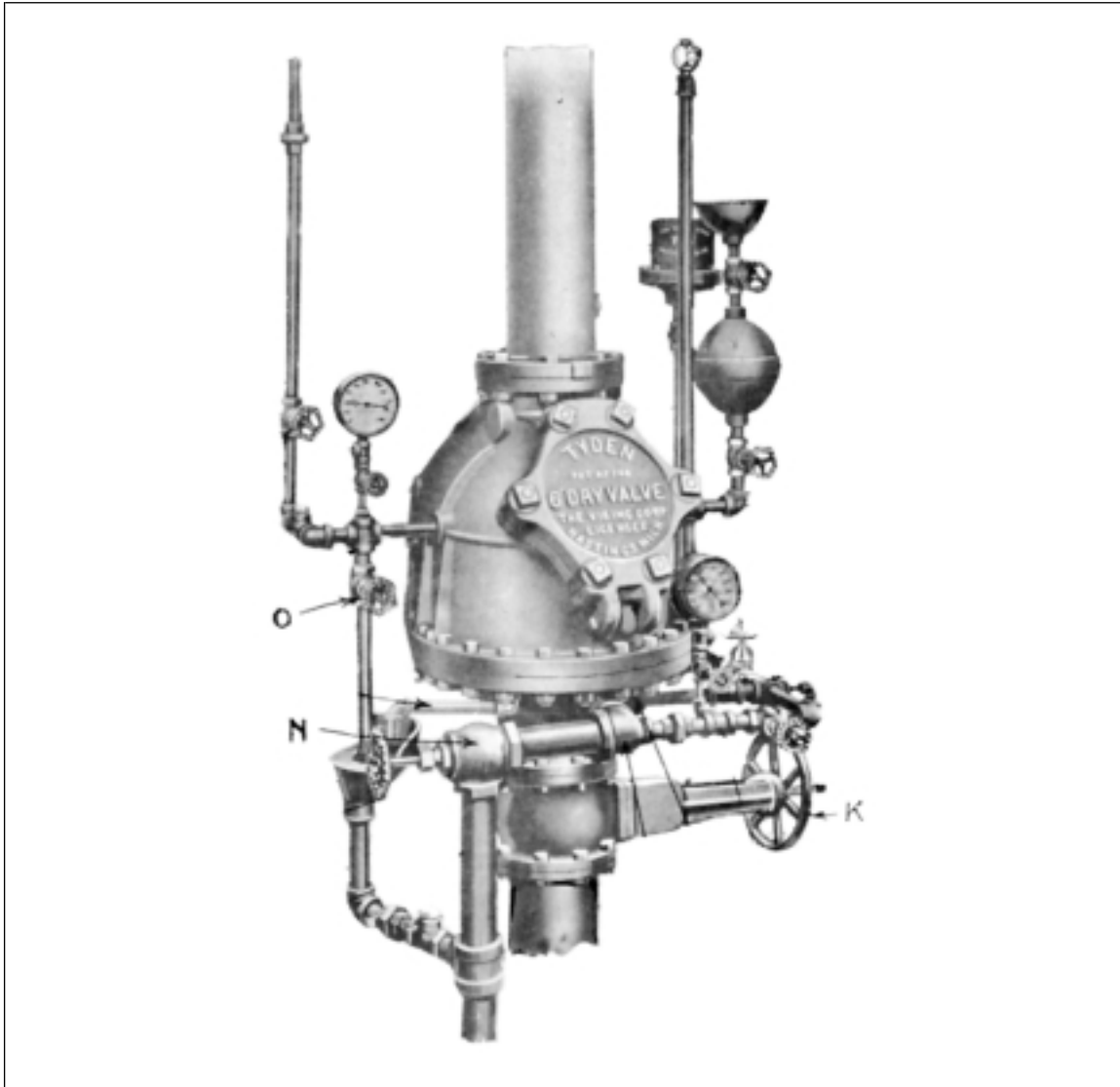

Fig. 97. Viking Tyden Models A and B trim.

2. Draw clapper E (Fig. 96) forward and slowly down through priming water to its seat, where it will remain.
3. Open drain valve N (Fig. 97) to take care of possible leakage past main gate valve K. Bolt cover C in place.
4. Put additional priming water through priming chamber to the level of valve O, and pump up system to the required air pressure.
5. Close drain valve N and open main gate valve K. Make sure that no leakage appears at drip valve J and that it is free to move.
6. Open drain valve N to test the water supply. Put the priming apparatus in service.

2.30 Viking Tyden Models A and B

Tyden Dry-Pipe Valve

MODEL A 3-INCH (76-mm)* 1929 TO 1936

Viking Corporation, Hastings, Mich.

DESCRIPTION

Tyden Model A is an angle dry valve (Fig. 98). Air pressure exerted on clapper 1 resists water pressure at a ratio of 1 psi (6.89 kPa) (0.069 bars) air to 10 psi (68.9 kPa) (0.69 bars) water pressure. Priming water must be put over clapper 1 to hold it on water seat 4.

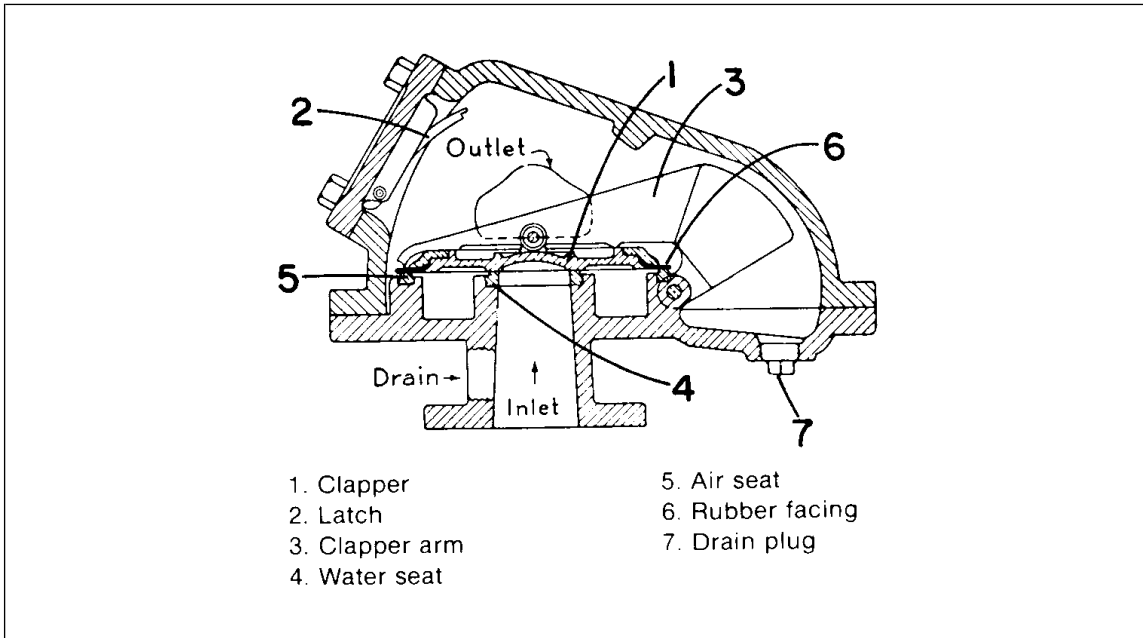

Fig. 98. Viking Model A dry-pipe valve, internal view.

When system air pressure is reduced sufficiently, water pressure will force clapper 1 open. Clapper 1 is then out of the waterway or held open by latch 2.

SETTING

1. Close main control valve.
2. Open main drain valve B (Fig. 99) and all drawoff valves and vents at low points throughout the system; close them when water ceases to flow. Also remove drain plug 7 (Fig. 98) and allow water to drain.

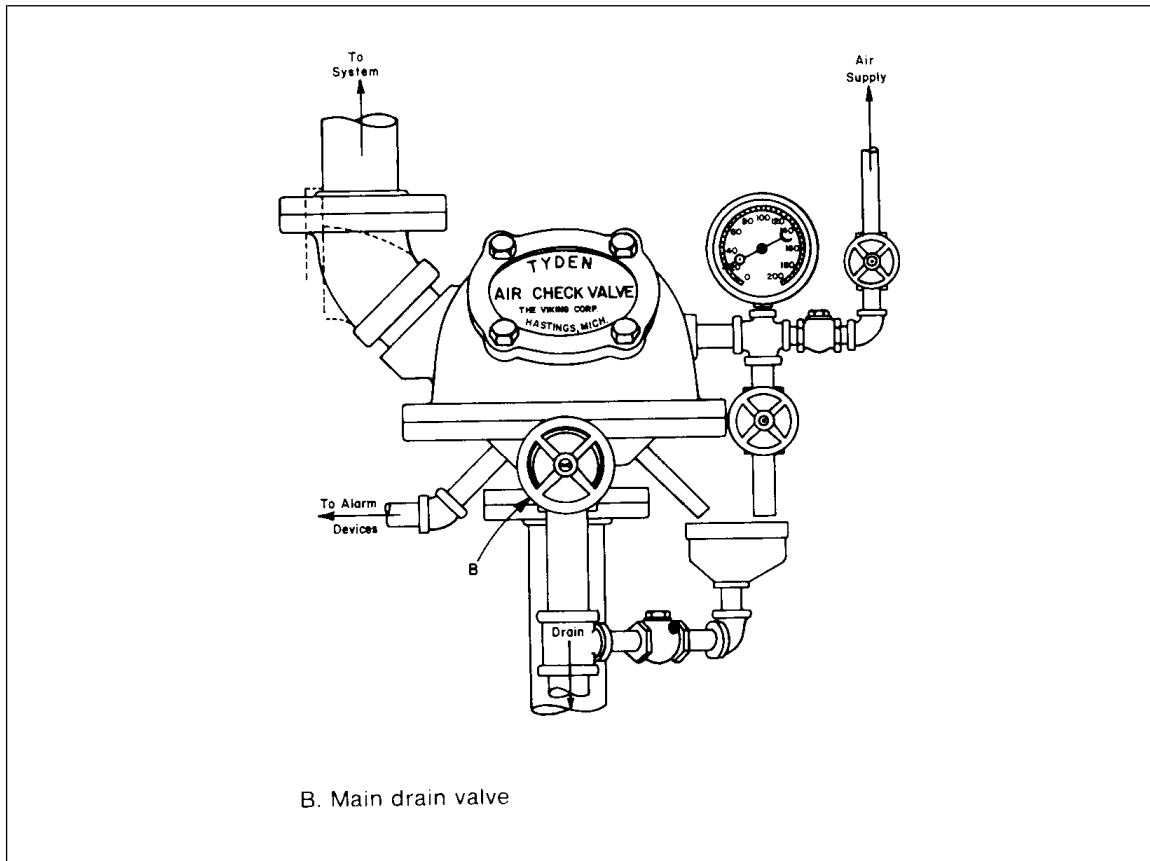

Fig. 99. Viking Model A dry-pipe valve with trim.

3. Remove cover of the dry valve.
 4. Raise clapper 1 and carefully clean water seat 4, air seat 5, and rubber facing 6.
 5. Admit priming water into the valve by slowly opening main control valve, until water is at a level with the bottom of the cover. Close main control valve when water reaches this level. Priming water may also be added by pouring through cover opening.
- *Formerly known as Air Check Valve.
6. Place clapper 1 on its seats. The priming water will hold clapper 1 down.
 7. Open main drain valve B and open the drip valve, allowing water to drain from the intermediate chamber.
 8. Replace cover of dry valve.
 9. Pump air into the system to a pressure equal to $\frac{1}{10}$ the water pressure plus 15 psi (103 kPa) (1.03 bars).
 10. Close main drain valve B.
 11. **Open wide main control valve**
 12. Make sure no leakage occurs at the drip valve.
 13. Test the water supply by opening main drain valve B.

3.0 EXHAUSTERS AND ACCELERATORS

3.1 Automatic (ASCOA) Model 1 Accelerator

“Automatic” Accelerator

MODEL 1 - 1933 TO DATE

“Automatic” Sprinkler Corp. of America, Youngstown, Ohio

DESCRIPTION

The “Automatic” Model 1 Accelerator (Fig. 100) can be used with practically all types of differential dry-pipe valves equipped with a velocity drip valve. In set position, air pressure enters lower chamber 1 and passes to upper chamber 2 via restriction pin 3. Spring 4 holds main valve 5 closed.

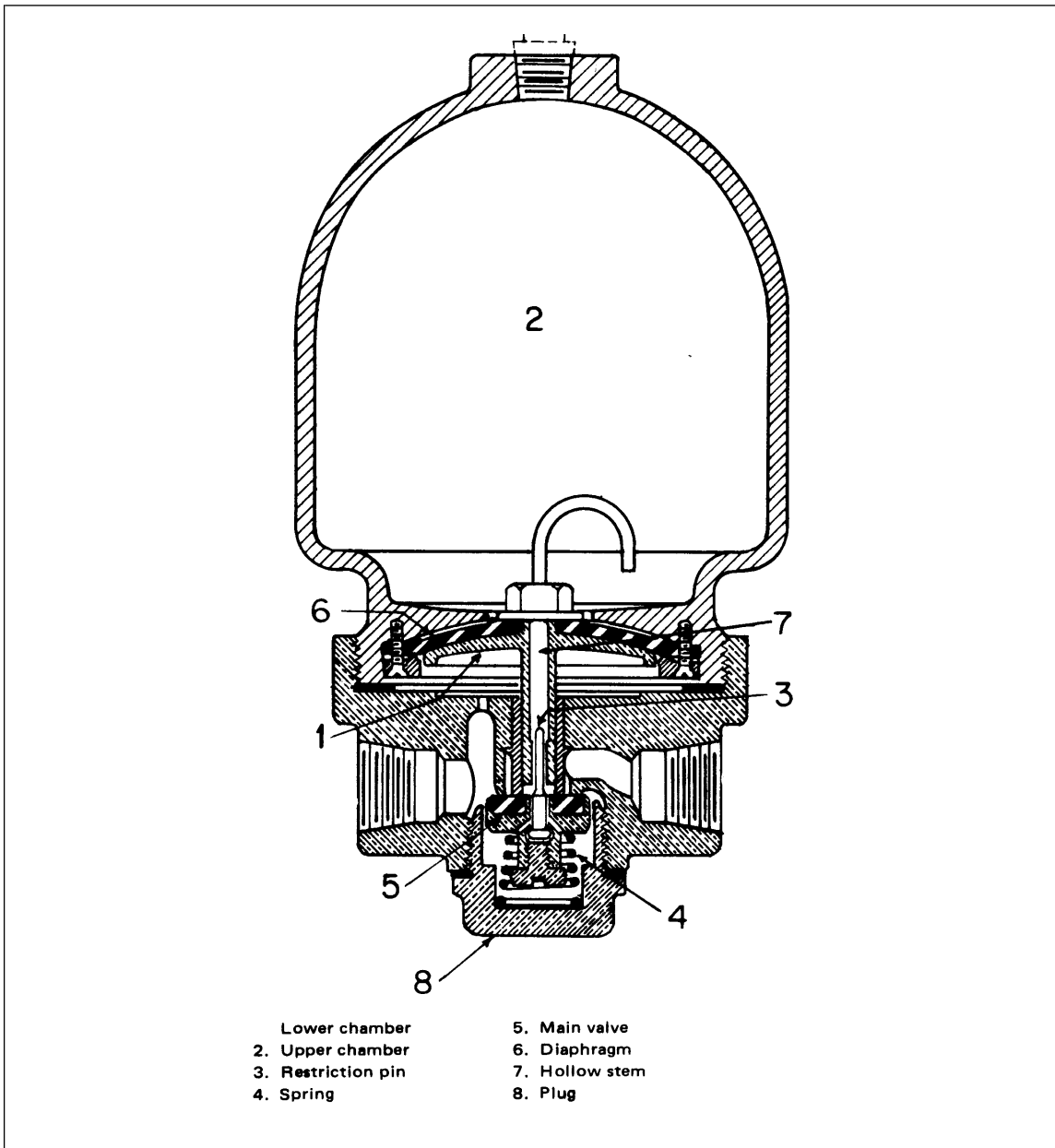

Fig. 100. “Automatic” accelerator Model 1, internal view

When system air pressure is reduced, air pressure in lower chamber 1 is reduced. Upper chamber 2 cannot reduce its pressure due to restriction pin 3. The excess pressure forces diaphragm 6 and hollow stem 7 down, opening main valve 5. Air from the sprinkler system passes through the accelerator to the intermediate chamber of the dry valve, destroying the differential and causing it to operate.

INSPECTION

1. Check that air supply valve C (Fig. 101) is wide open.

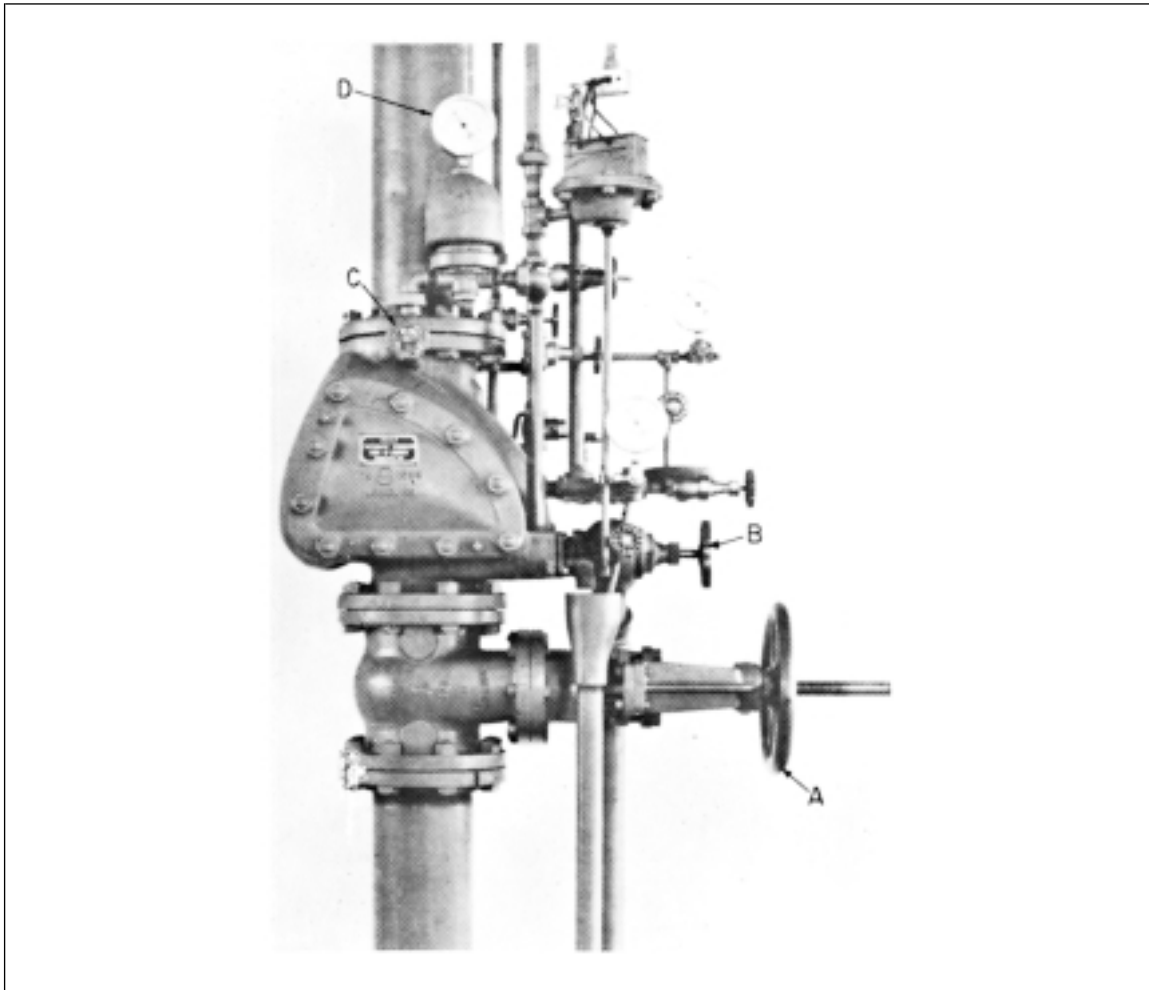

Fig. 101. "Automatic" accelerator Model 1 trim.

2. Read pressure gauge D. It should indicate the same pressure as that in the sprinkler system. If the pressures differ, increase system pressure a few pounds and note if pressure gauge D increases a similar amount. If pressures do not read the same, restriction pin 3 is plugged. Close air supply valve C and remove plug 8. Spring 4, main valve 5, and restriction pin 3 should also be removed. Restriction pin 3 should be cleaned and the whole assembly replaced in the accelerator. Open air supply valve C. If the pressures still do not equalize, close air supply valve C tightly and send the accelerator to the manufacturer for repairs. Make sure the connecting pipe to the intermediate chamber of the dry valve is plugged. The dry-pipe valve will operate without the accelerator.
3. Check priming water level in the dry valve. Priming water should not be allowed to reach the level of air supply valve C.
4. Check air supply valve C to make sure it is wide open.

TESTING

1. Close main control valve A.
2. Close air supply valve C.
3. Open main drain valve B.
4. Loosen plug 8, and the accelerator should operate. Pressure gauge D will drop when the accelerator operates. Tighten plug 8.
5. Close main drain valve B.
6. Follow steps 3 to 6 under **SETTING**.

SETTING

1. Close air supply valve C and set the dry pipe valve using the appropriate data sheet or manufacturer's instructions. Do not open main control valve A until later.
2. Remove plug 8, main valve 5, and restriction pin 3. Any water in upper chamber 2 can now drain out through hollow stem 7. Clean restriction pin 3 and main valve 5 and replace plug 8.
3. Open air supply valve C. Note if air leaks by main valve 5 by listening at the drip valve.
4. Check pressure gauge D. It should slowly rise to the same pressure as that in the sprinkler system. (This will take about 10 min.)
5. Open wide main control valve A.
6. Test the water supply by opening main drain valve B.

3.2 Automatic (ASCOA) Model 185 Accelerator

"Automatic" Accelerator

MODEL 185 WITH A BUILT-IN ANTIFLOODING MECHANISM

"Automatic" Sprinkler Corporation of America Div. American Lafrance, Sub. A-T-O, Cleveland, Ohio

DESCRIPTION

The "Automatic" Model 185 accelerator (Fig. 102) has three basic components: transducer 1, release mechanism 2, and an antiflooding valve.

The antiflooding valve consists of body 5, valve spool 4, spring 6, and seals 7. The latter three components make up what is called the piston assembly. This assembly has four seals 7 and 12. Two smaller seals 12 prevent air from leaking to the intermediate chamber of the dry valve when the accelerator is set. The remaining two larger seals 7 prevent dirty water from entering transducer 1 when the accelerator trips.

Transducer 1 contains spring 9, piston 10, and transducer diaphragm 11. The upper portion is connected to release mechanism 2 via copper tubing 3, while the lower portion is connected to antiflooding valve body 5.

Release mechanism 2 contains a diaphragm connected to a series of levers and springs which hold the piston assembly in the open position when the accelerator is set.

OPERATION

In set condition, air pressure in the sprinkler system enters the valve body and supplies pressure to the underside of the spring loaded piston in the transducer (Fig. 103-A). The release mechanism is cocked and holds the piston assembly open. When system air pressure is reduced suddenly, air pressure under piston 10 (Fig. 102) is also reduced. Spring 9 (Fig. 102) pushes piston 10 (Fig. 102) downward creating a vacuum in the upper chamber of the transducer and on one side of the release diaphragm. The diaphragm (Fig. 103) moves releasing the lever system. The piston assembly moves allowing air to enter the intermediate chamber of the dry valve (Fig. 103-C). After the dry valve has tripped, seals 12 (Fig. 102) on valve spool 4 (Fig. 102) prevent water from entering the lower portion of the transducer.

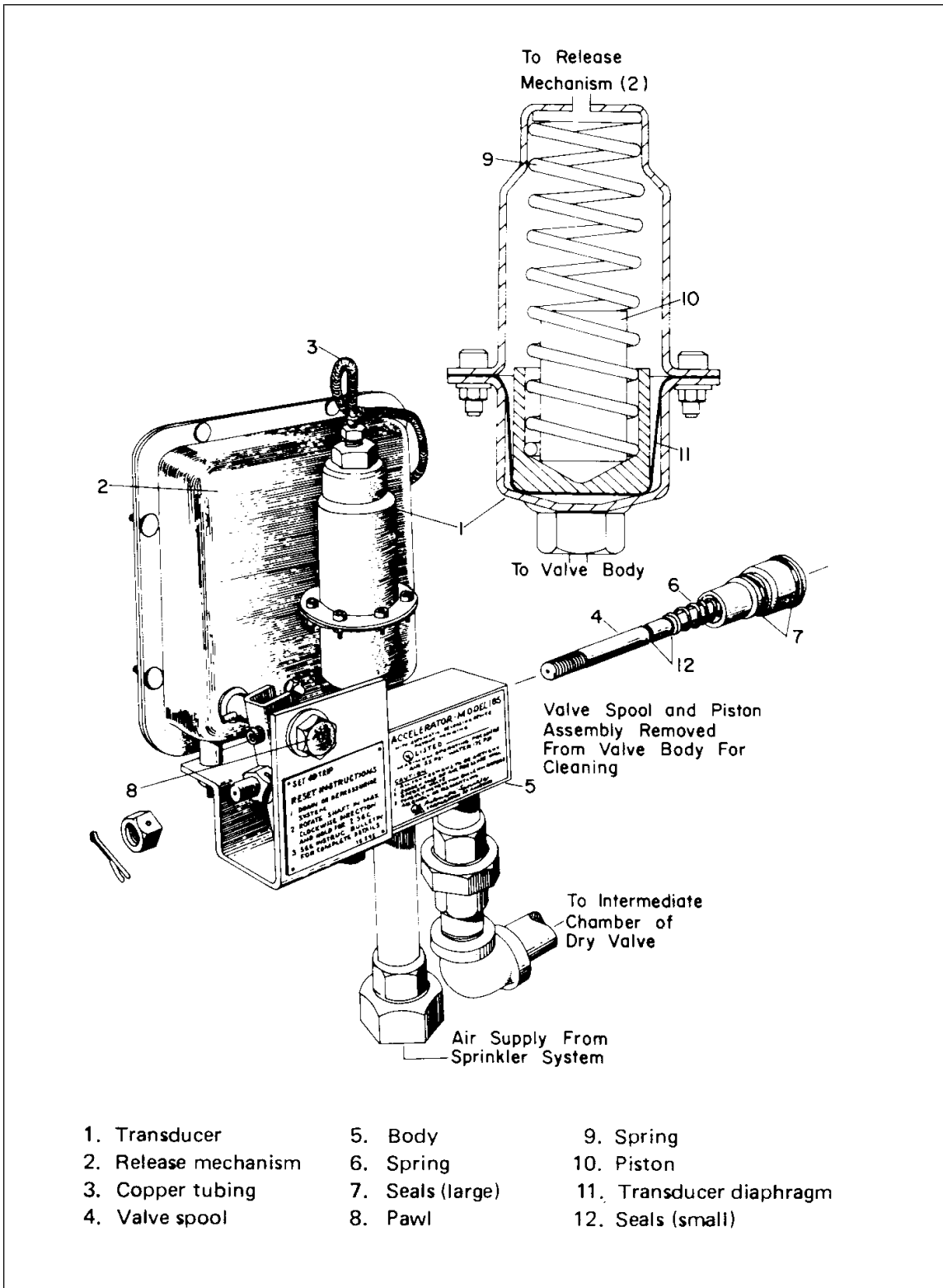

Fig. 102. "Automatic" Model 185 accelerator components

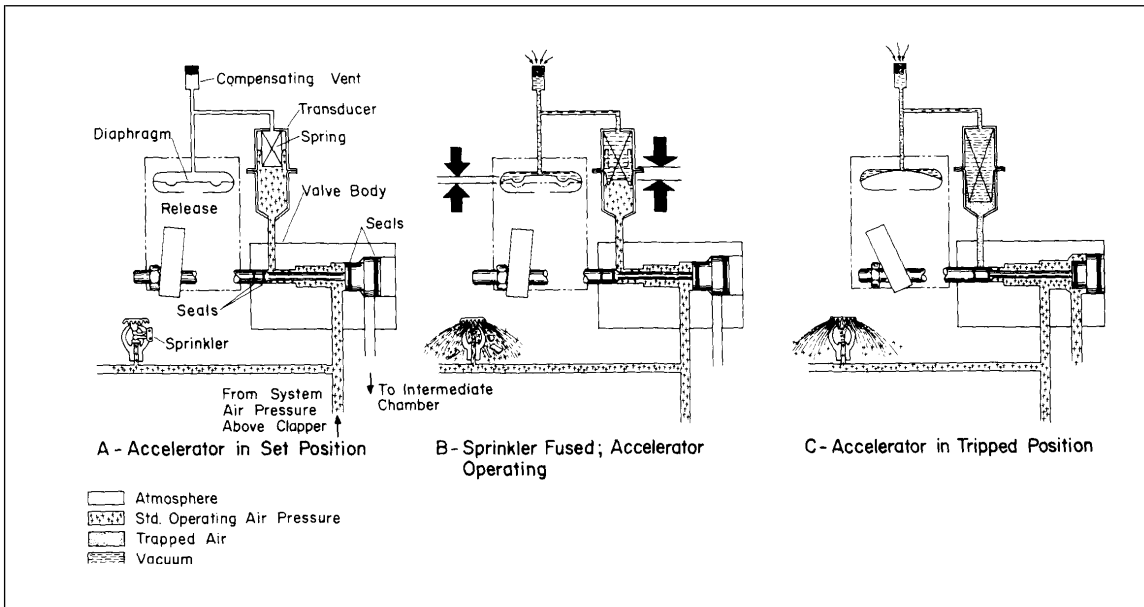

Fig. 103. "Automatic" Model 185 accelerator in operation.

INSPECTION

1. Check that air supply valve A (Fig. 104) is wide open.

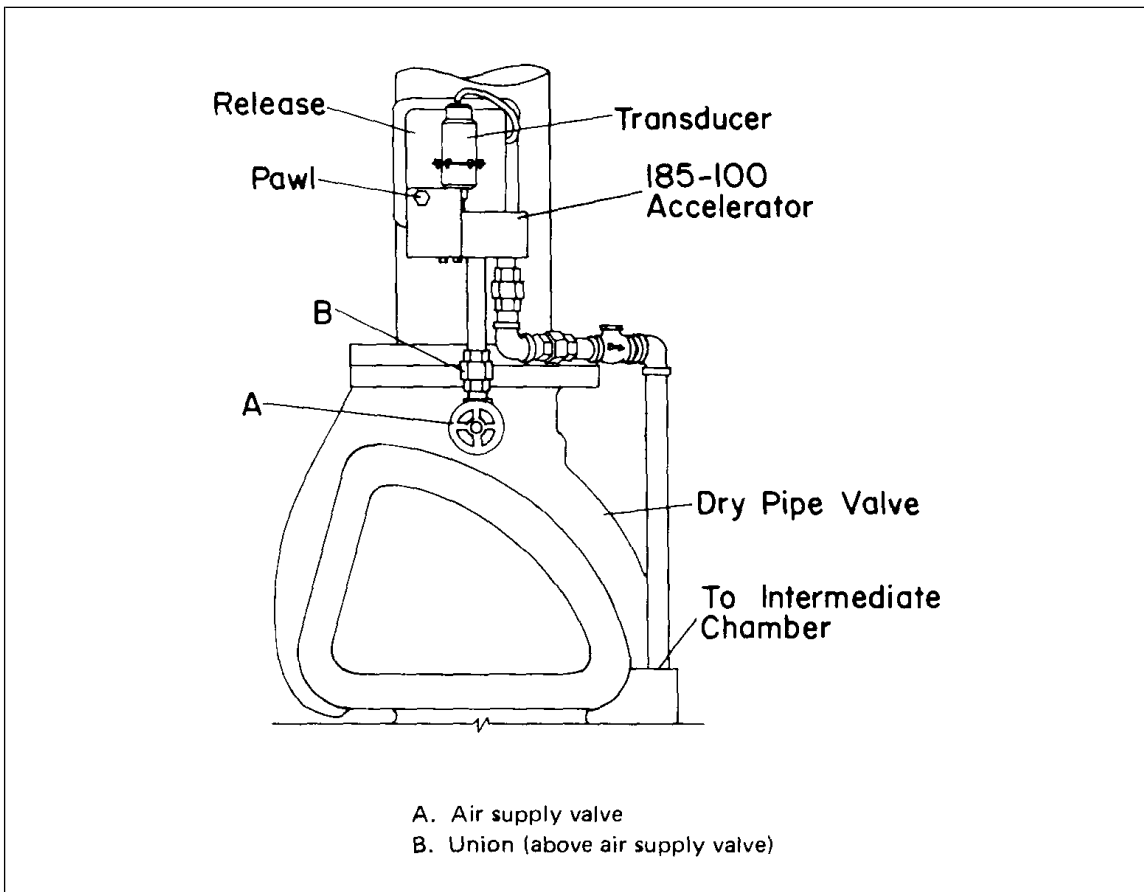

Fig. 104. "Automatic" Model 185 accelerator trim.

2. Check that pawl 8 (Fig. 102) is in the set position.

TESTING

1. Close air supply valve A (Fig. 104).
2. Close the main control valve supplying water to the dry-pipe valve.
3. Open the main drain valve of the dry valve.
4. Loosen union B (Fig. 104) so that air can escape. The accelerator should operate. Tighten union B when finished.
5. Close the main drain valve.
6. Follow steps 2 to 5 as outlined in the procedure for setting the accelerator.

SETTING

1. Close air supply valve A (Fig. 104) and set the dry valve, using the appropriate data sheet or manufacturer's instructions. Do not open the main control valve until later.
2. Rotate pawl 8 (Fig. 102) clockwise and open air supply valve A. The accelerator is set when the pawl will no longer return to its counter-clockwise tripped position. (Approximately 8 min should elapse before pawl 8 will remain in correct position.)
3. Make sure air supply valve A is open wide.
4. Open wide the main control valve.
5. Test the water supply by opening the main drain valve.

3.3 Automatic (ASCOA) Model A Exhauster

Automatic Exhauster

MODEL A, 1921 TO 1927

Automatic Sprinkler Company of America, Youngstown, Ohio

DESCRIPTION

Automatic Model A Exhauster is designed for use with the Automatic Model A dry-pipe valve, but can be used with practically all types of dry valves by use of an adapter. The exhauster (Fig. 105) consists of upper chamber 1, lower chamber 2, rubber diaphragm 3, restriction assembly 6, 7, 8, 9 and 10, and outlet valve assembly 12 and 13. In set conditions air pressure from above the dry valve enters lower chamber 1 of the exhauster. This air pressure passes through restriction orifice 8 and creates equal pressure in the upper and lower chambers. Release disc 13 is held closed by spring 12.

When system air pressure is released by the opening of a sprinkler, lower chamber 2 exhausts its air pressure and upper chamber 1 cannot, due to restriction orifice 8, exhaust its air pressure as fast. This causes excess pressure in upper chamber 1 which forces rubber diaphragm 3, diaphragm plate 5, and push rod 11 down. Release disc 13 opens, allowing air to enter the intermediate chamber of the dry valve.

INSPECTION

1. Check that air valve B (Fig. 106) is wide open.
2. Check that pressure gauge C indicates the same pressure as that in the sprinkler system. If the pressures differ, increase sprinkler pressure a few pounds and note if pressure gauge C increases a similar amount. (This will take about 10 min.) If the pressures still differ, restriction orifice 8 and screens 10 are probably plugged. Close air valve B and remove plug 6. Unscrew orifice housing 7 and carefully clean screens 10 and restriction orifice 8. Replace orifice housing 7 and plug 6 making sure all joints are tight. Open air valve B. Check pressure gauge C. It should slowly (in about 10 minutes) reach the same pressure as that in the sprinkler system. If the orifice is still obstructed, the accelerator should be replaced with an approved device.
3. Open test valve E on the dry-pipe valve and slightly open test cock D on the exhauster. If any water appears, draw it off; then close these valves to prevent an accumulation of water from obstructing the restriction orifice, making the exhauster inoperative or causing it to trip prematurely.

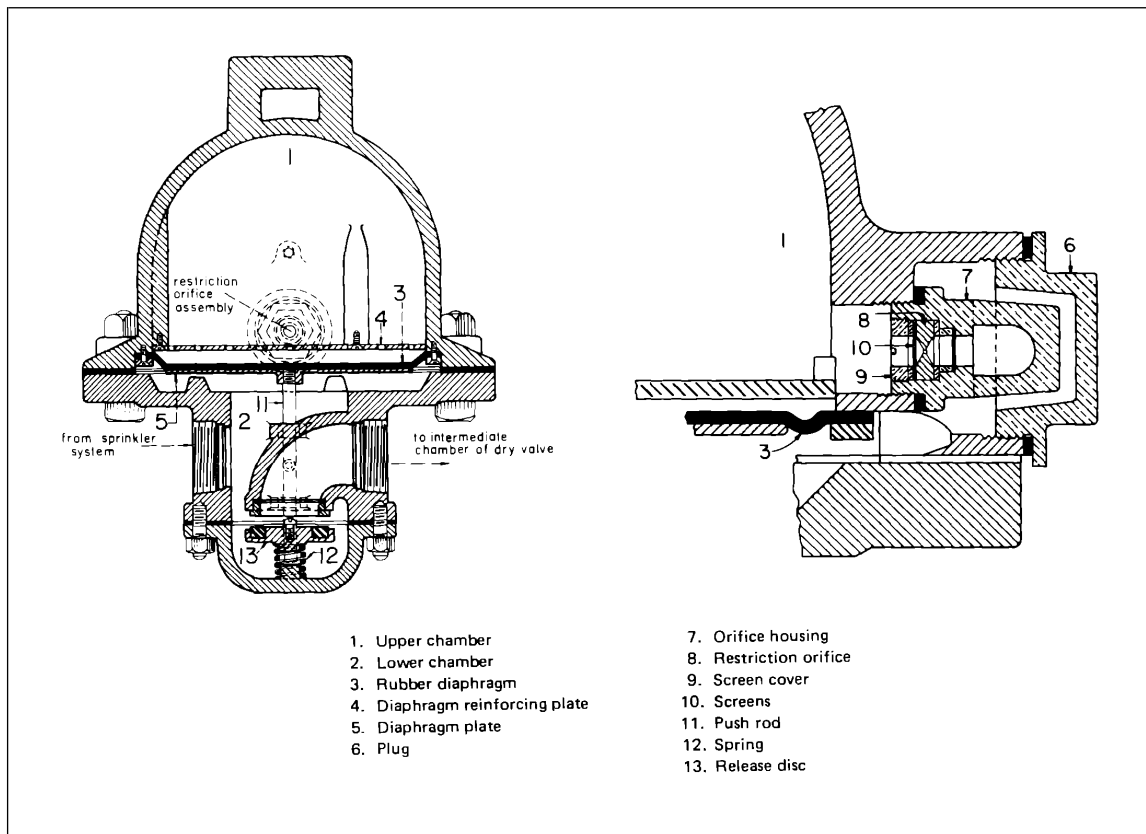

Fig. 105. "Automatic" exhauster Model A. A, internal view; B, close-up of restriction assembly.

TESTING

The exhauster may be tested or operated without tripping the dry-pipe valve as follows:

1. Close air valve B.
2. Close the main control valve.
3. Open main drain valve A. Close when water ceases to flow.
4. Open test cock D to drop air pressure in the body rapidly and trip the exhauster. Close test cock D when finished.
5. Reset the accelerator as outlined in Steps 6 to 8 under **SETTING**.

SETTING

1. Close air valve B and set the dry valve in the usual manner.
2. Remove plug 6 and orifice housing 7 to drain the dome of any water which may have accumulated.
3. Wash thoroughly orifice housing 7 and screens 10.
4. Replace orifice housing 7, screwing it tightly against its seat. It is essential that this joint be absolutely tight, because a leak at this point would retard the action of the exhauster.
5. Replace plug 6, making sure that the joint is tight.
6. Open air valve B; note if any air is escaping from release disc 13 by listening at drip valve F of the dry valve. If you can hear air escaping, close air valve B, remove the cover on the lower chamber of the exhauster and clean the valve assembly.

If air is not escaping, observe pressure gauge C. Pressure should be slowly rising. About 10 minutes is needed for the pressure in upper chamber 1 to equalize with that in the dry system.

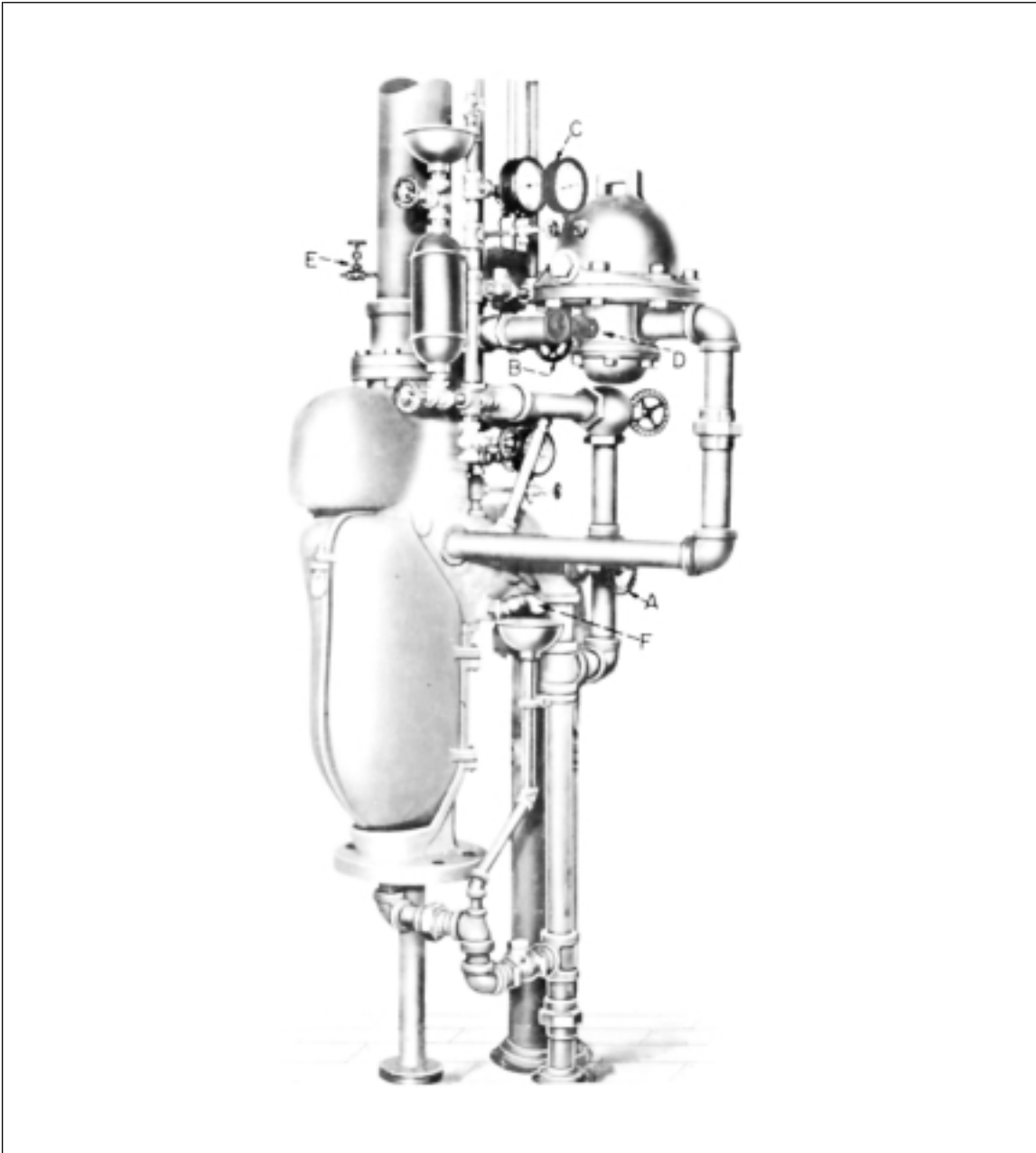

Fig. 106. "Automatic" exhauster, Model A trim.

7. **Open wide the main control valve.**
8. Check water supply by opening main drain valve A.

CONNECTING TO OTHER DRY-PIPE VALVES

The Automatic Model A exhauster can be attached to any differential or mechanical dry-pipe valve, as shown in Fig. 107. The purpose of this exhauster adapter is to close the exhauster discharge after the dry-pipe valve has tripped, thus preventing waste of water. The adapter is an automatic diaphragm valve and does not require setting.

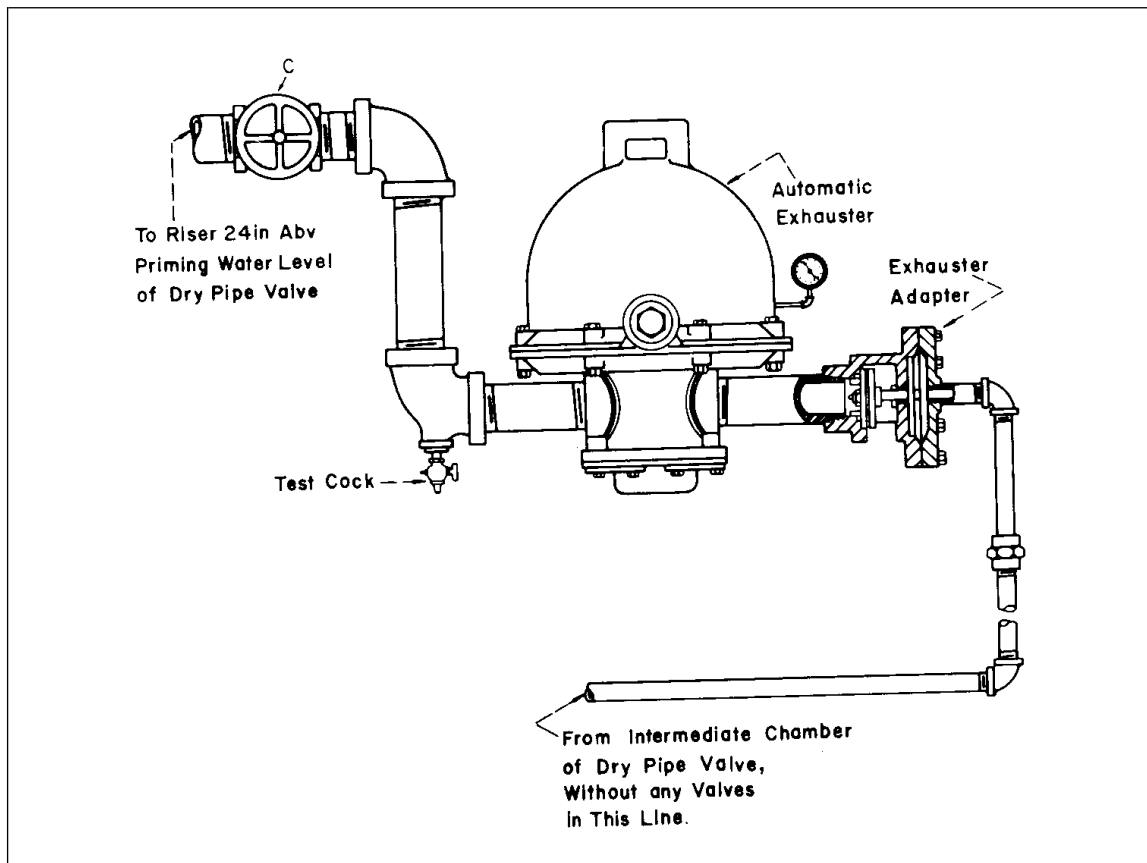

Fig. 107. Exhauster adapter with "Automatic" Model A exhauster.

3.4 Automatic (ASCOA) Model B Exhauster

"Automatic" Exhauster
MODEL B, 1927 - 1970

"Automatic" Sprinkler Corp. of America, Cleveland, Ohio

DESCRIPTION

The "Automatic" Model B exhauster (Fig. 108, A and B) is designed for use with the "Automatic" Model B dry-pipe valve, but may be used with practically all makes of differential or mechanical dry valves. In set position air pressure from the sprinkler system enters lower chamber 1, passes through passageway 4 to middle chamber 2, and finally through restriction orifice 5 to upper chamber 3. The pressure is equalized in these chambers, while spring 8 holds exhaust valve 9 closed.

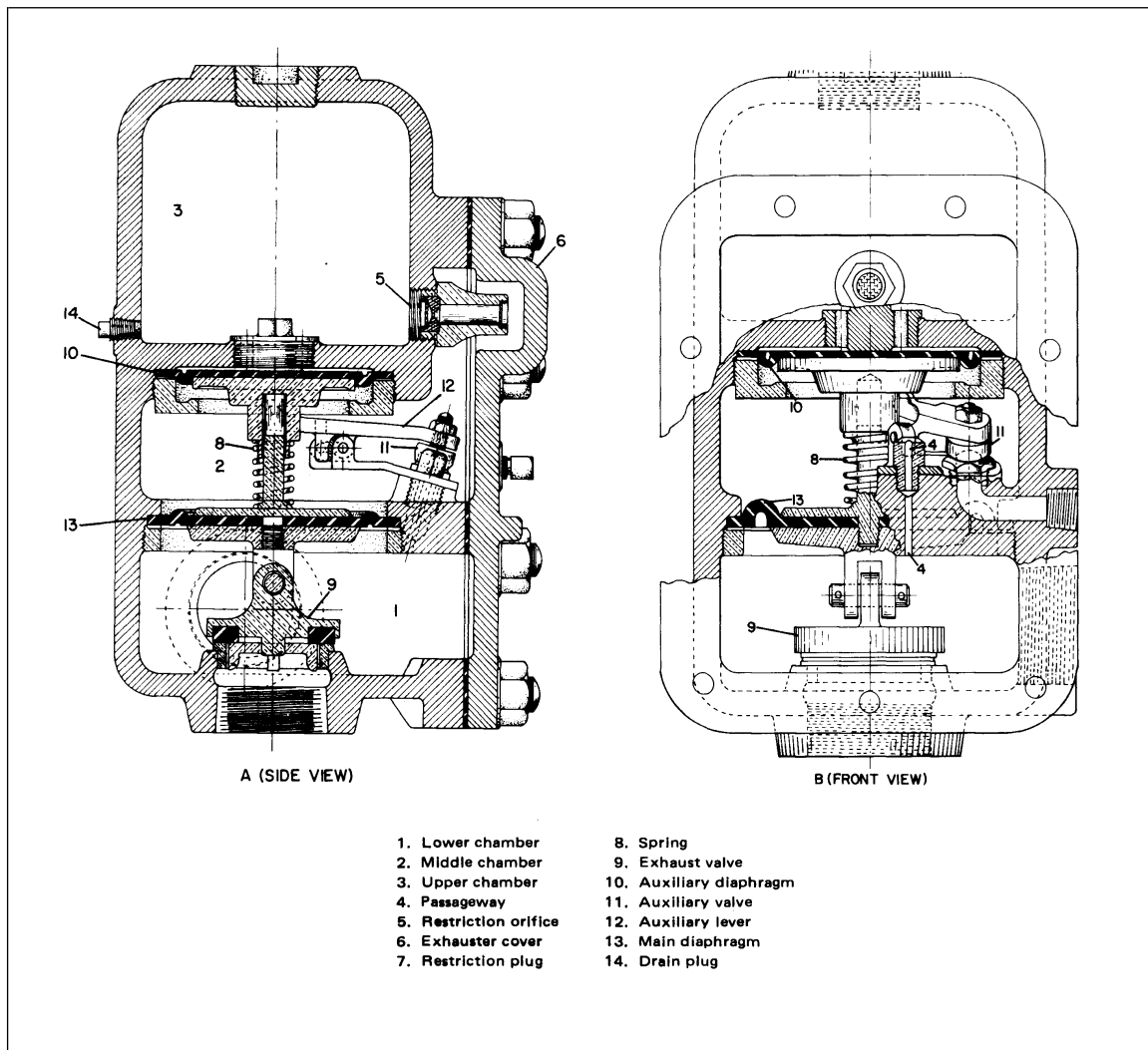

Fig. 108. Automatic Model B exhauster.

When system pressure is reduced, air pressure in the lower and middle chambers is also reduced. Pressure in upper chamber 3 cannot relieve its pressure due to restriction orifice 5. The excess pressure forces auxiliary diaphragm 10 down, opening auxiliary valve 11. Pressure in middle chamber 2 is exhausted through auxiliary valve 11, and due to the size of passageway 4, lower chamber 1 has an excess pressure. This pressure forces main diaphragm 13 up, opening exhaust valve 9. Sprinkler system air pressure now passes through the exhauster to the outlet drain.

After the dry valve trips, water from the intermediate chamber of the dry valve enters middle chamber 2 through auxiliary valve 11. Water also enters lower chamber 1. Pressures between these two chambers are equalized and spring 8 holds exhaust valve 9 closed, thus preventing waste of water.

INSPECTION

1. Check that air supply valve C (Fig. 109) and valve E are wide open.
2. Check that pressure gauge D indicates the same pressure as that in the sprinkler system. If the pressures differ, increase sprinkler pressure a few pounds and note if pressure gauge D increases a similar amount. (This will take about 5 minutes.) If the pressures still differ, restriction orifice 5 is probably plugged. Close air supply valve C and remove exhauster cover 6. Remove restriction plug 7 and carefully clean restriction orifice 5 and the screens on both sides of the orifice. Replace restriction plug 7 and exhauster cover 6 making sure all joints are tight. Open air supply valve C. Check pressure gauge D. It should slowly (in about

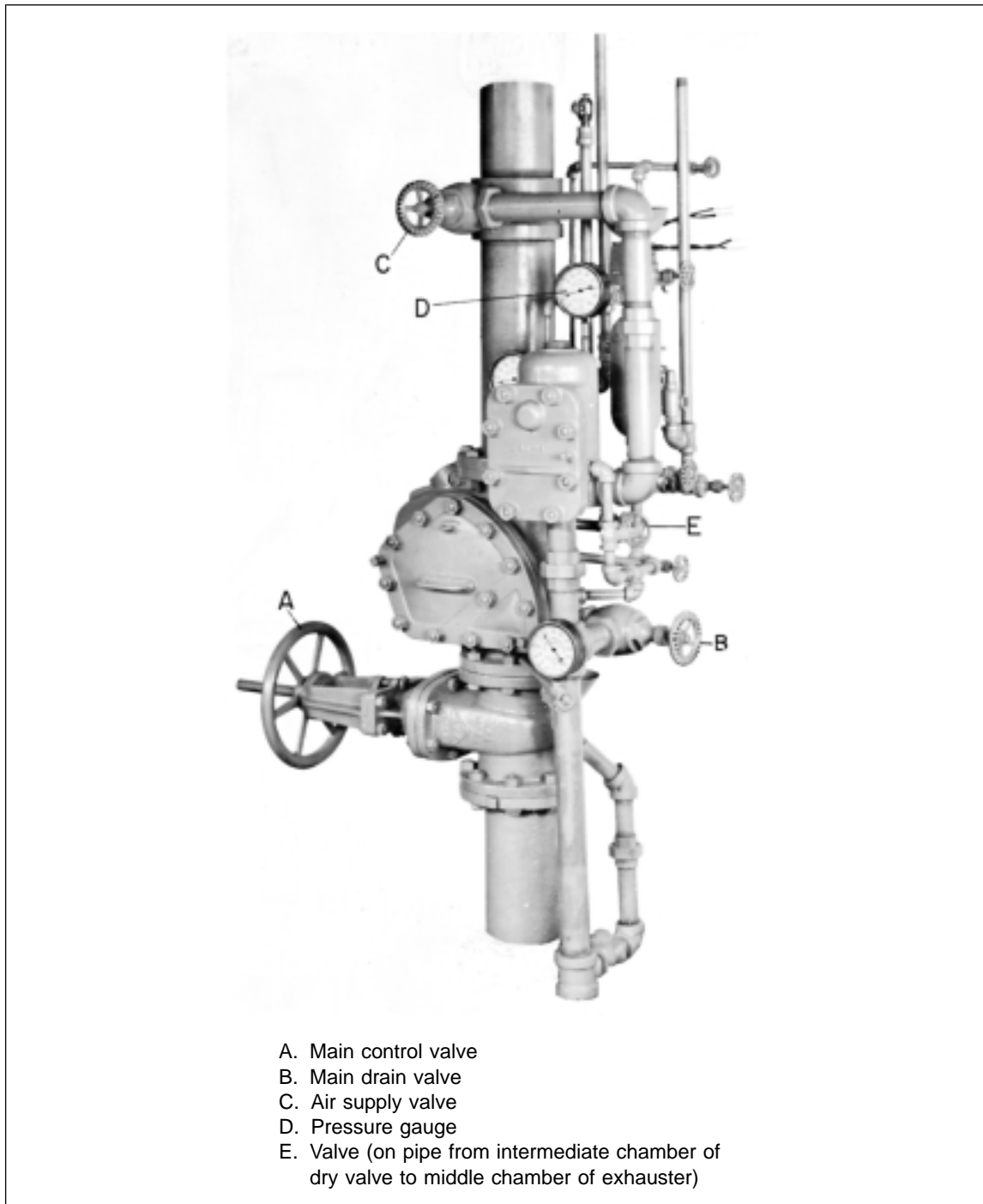

Fig. 109. Automatic exhauster trim.

10 minutes) reach the same pressure as that in the sprinkler system. If the orifice is still plugged, close air supply valve C and send restriction plug 7 with the screens to the manufacturer for repair. The dry valve will still operate in this condition.

3. Check the level of priming water in the dry-pipe valve. Priming water should never reach the level of air supply valve C.

4. Check that air supply **valve C is wide open.**

TESTING (Without tripping dry valve)

1. Close air supply valve C.
2. Close main control valve A.
3. Open main drain valve B.
4. Remove plug in the air supply line to the exhauster. The exhauster should trip. After the test, relieve pressure in the upper chamber by loosening pressure gauge D. Tighten pressure gauge D.
5. Close main drain valve B.
6. Follow steps 6 to 8 under **SETTING**.

SETTING

1. Close air supply valve C and set the dry valve, using the appropriate data sheet or manufacturer's instructions. Do not open main control valve A until later.
2. Remove exhauster cover 6.
3. Remove restriction plug 7 and allow any water to drain from upper chamber 3. Carefully clean restriction orifice 5 and its screens. Replace restriction plug 7 making sure joint is tight.
4. Lift auxiliary valve 11 and check for dirt or an obstruction; then place on its seat. Check exhaust valve 9 to make sure it is firmly on its seat.
5. Replace exhauster cover 6.
6. Open air supply valve C and allow the pressure to reach the level of air pressure in the sprinkler system. Note if any air is leaking past exhaust valve 9. Open valve E.
7. **Open wide main control valve A.**
8. Test the water supply by opening main drain valve B.

Caution: When the dry valve is left wet, care should be taken that air supply valve C and valve E are closed tightly. Also remove the plug in the air supply line to the exhauster so that any water leaking past air supply valve C will drain. The alarms for the dry valve will not operate when the valve is left wet.

3.5 Central Lewis Model A Exhauster

Central Exhauster

LEWIS MODEL A1930 TO DATE

Central Automatic Sprinkler Co., Philadelphia, PA.

DESCRIPTION

The Model A exhauster (Fig. 110) may be used with practically all types of dry-pipe valves. In set condition, air pressure enters lower chamber 5 and travels through passageway 6 to auxiliary chamber 2 and upper chamber 1. The pressure in these chambers is equalized while springs 7 and 8 hold their respective valves closed.

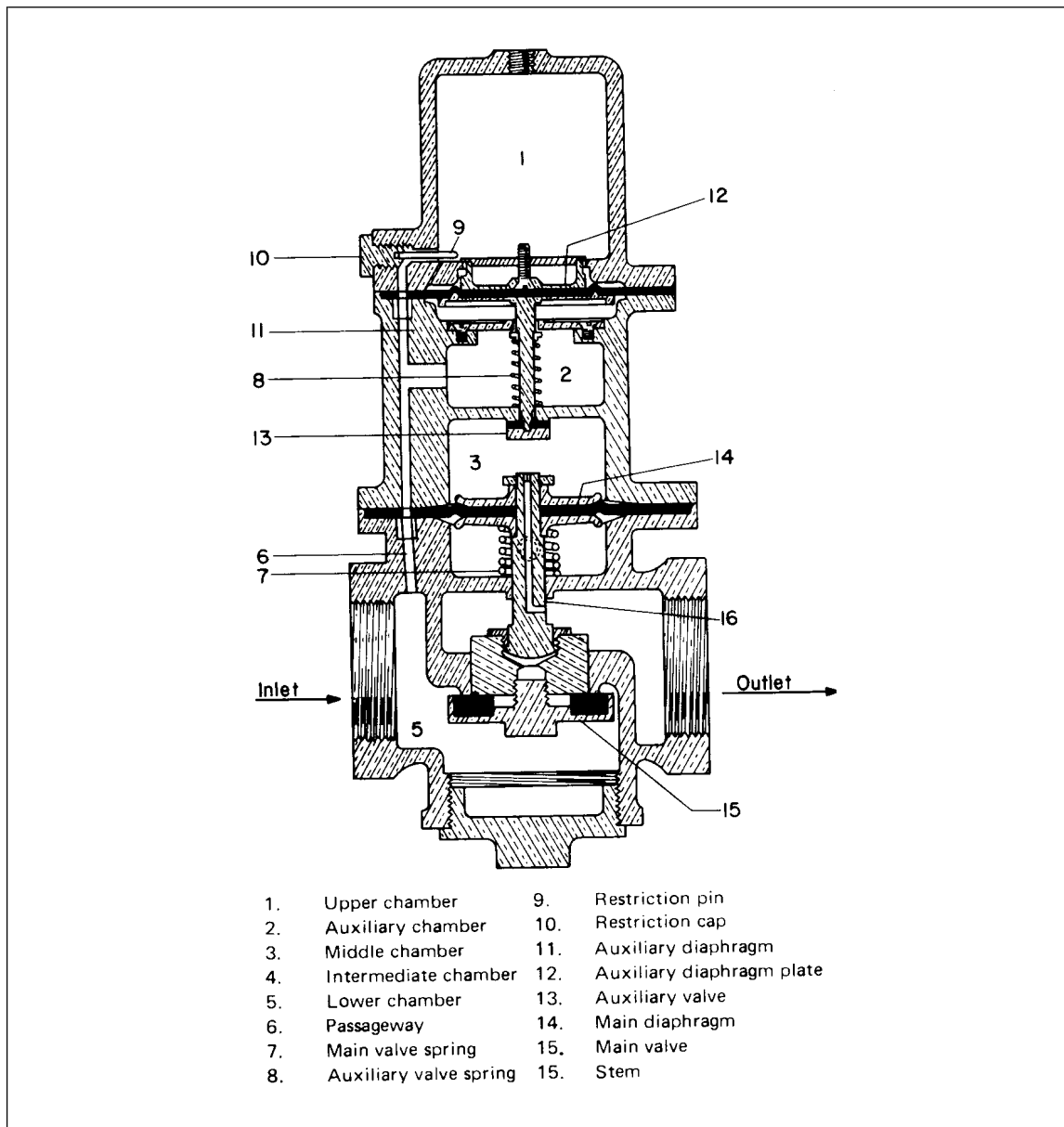

Fig. 110. Lewis Model A exhauster, internal view.

When sprinkler system pressure drops suddenly, air pressure in auxiliary chamber 2 also drops. Upper chamber 1 cannot exhaust its pressure due to restriction pin 9. This pressure forces auxiliary diaphragm 11 and auxiliary diaphragm plate 12 down. Auxiliary valve 13 opens, admitting pressure to middle chamber 3 which forces down main diaphragm 14 and stem 16, opening main valve 15. Sprinkler system air pressure now passes through the exhauster to the outlet drain.

After the dry valve trips, water from the intermediate chamber enters intermediate chamber 4 of the exhauster. The pressure of the water, aided main valve spring 7, closes main valve 15 and prevents any water from being wasted through the outlet drain.

INSPECTING OF EXHAUSTER

1. Check that air supply valve C is open.

2. Read pressure gauge D. It should indicate the same pressure as that in the sprinkler system. If the pressures differ, increase sprinkler pressure a few pounds and note if pressure gauge D increases a similar amount. (This will take about 10 min.) If the pressures still differ, restriction pin 9 is probably plugged. Close air supply valve C and remove restriction cap 10 with restriction pin 9 connected to it. Carefully clean restriction pin 9 and its holder. Replace restriction pin 9 making sure the joint is tight. Open air supply valve C. If restriction pin 9 is still obstructed, the exhauster should be returned to the manufacturer for repair. If this is done, make sure air supply valve C is closed tightly. Although the exhauster will be out of service, the dry-pipe valve will remain operative.

3. Check level of priming water in the dry-pipe valve, as water should not be allowed to reach the level of air supply valve C. Open test cock E slightly and draw off any water which might have accumulated. Close when finished.

4. Make sure air supply valve C is open after inspecting the exhauster.

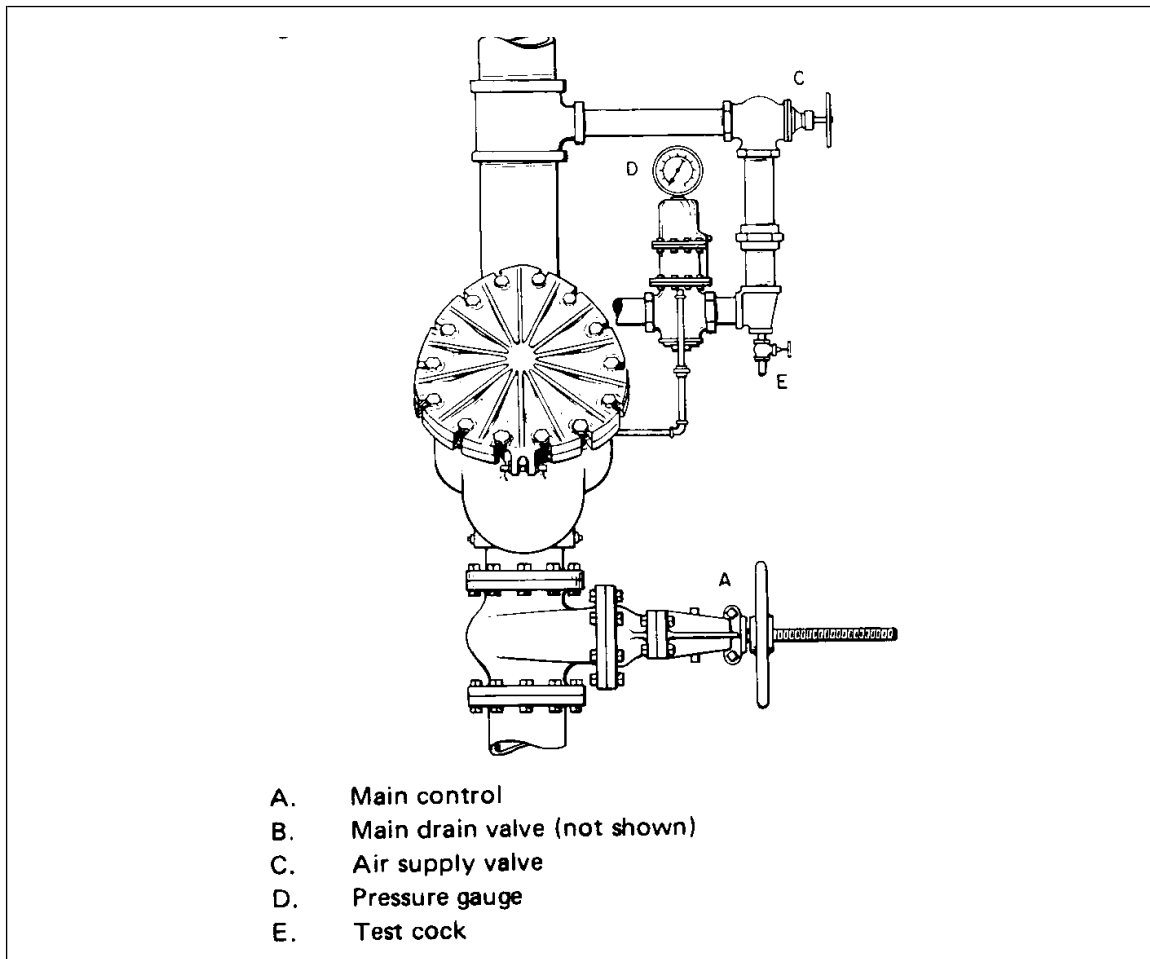

Fig. 111. Lewis Model A exhauster trim.

TESTING

(Without tripping dry-pipe valve)

1. Close air supply valve C.
2. Close main control valve A.
3. Open main drain valve B (not shown in Fig. 111).

4. Open test cock E, which will lower the pressure in the exhauster and cause it to operate. Close tight when finished.
5. Close main drain valve B.
6. Follow steps 4 to 7 outlined under **Setting**.

SETTING

1. Close main control valve A and set the dry-pipe valve using the appropriate data sheet or manufacturer's instructions. Do not open main control valve A until later.
2. Open test cock E and drain any water which may have accumulated. Close tightly when water ceases to flow.
3. Remove restriction pin 9 and carefully clean it. Replace restriction pin 9 making sure joint is tight. It is essential that this joint be tight because any air leakage would retard the action of the exhauster.
4. Open air supply valve C and check if main valve 15 is properly seated by noticing if any air escapes through the outlet of the exhauster.
5. Observe pressure gauge D. It should slowly rise to the same pressure as in the sprinkler system.
6. **Open main control valve A wide.**
7. Test the water supply by opening main drain valve B.

3.6 Central Model AD Accelerator

Central Dry-Pipe Accelerator Model AD

1947-TO-DATE

Central Automatic Sprinkler Co., Inc., Lansdale, Pa.

Designed for use with Central Model AD Dry-Pipe Valve

DESCRIPTION

The inlet is connected to the sprinkler system with a 1/4-inch valved connection containing a strainer and clean-out plug.

The valve chamber (11) and pressure chamber (14) are separated by an auxiliary valve diaphragm (8). The outlet chamber (16) is connected to the valve chamber (11) by an opening normally sealed closed by a spring loaded auxiliary valve (15).

System air enters the valve chamber through a 1/4-inch connection, and flows through an orifice restricted by a pin (4) into the pressure chamber where it slowly equalizes with the pressure in the valve chamber. A drop in system pressure due to fusing of a sprinkler head or opening of the inspector's test connection, will be reflected immediately in the valve chamber (11) and slowly in the pressure chamber (14) creating a differential pressure which moves the diaphragm down, opens valve (15), allowing system pressure to enter the outlet chamber (16) and then pass to the dry-pipe valve Sylphon housing. The low velocity check valve in the Sylphon housing of the dry-pipe valve automatically closes and the air pressure neutralizes the pressure inside the release sleeve to trip the valve. The low velocity check valve must be operated manually to relieve pressure before resetting the dry valve.

DIRECTIONS FOR INSPECTION

Note if the pressure as indicated by the gage on the accelerator is the same as that in the dry system. (If the pressures are not the same, increase that in the system a few pounds and note if pressure indicated by the accelerator gage slowly increases a similar amount. If not, it indicates that the restricted passage is plugged. See instructions in resetting directions for clearing a plugged passage.)

Make sure, after inspecting the accelerator, that the 1/4-inch valve in the accelerator supply line is wide open.

DIRECTIONS FOR TESTING ACCELERATOR

This accelerator can only be tested by tripping the dry-pipe valve.

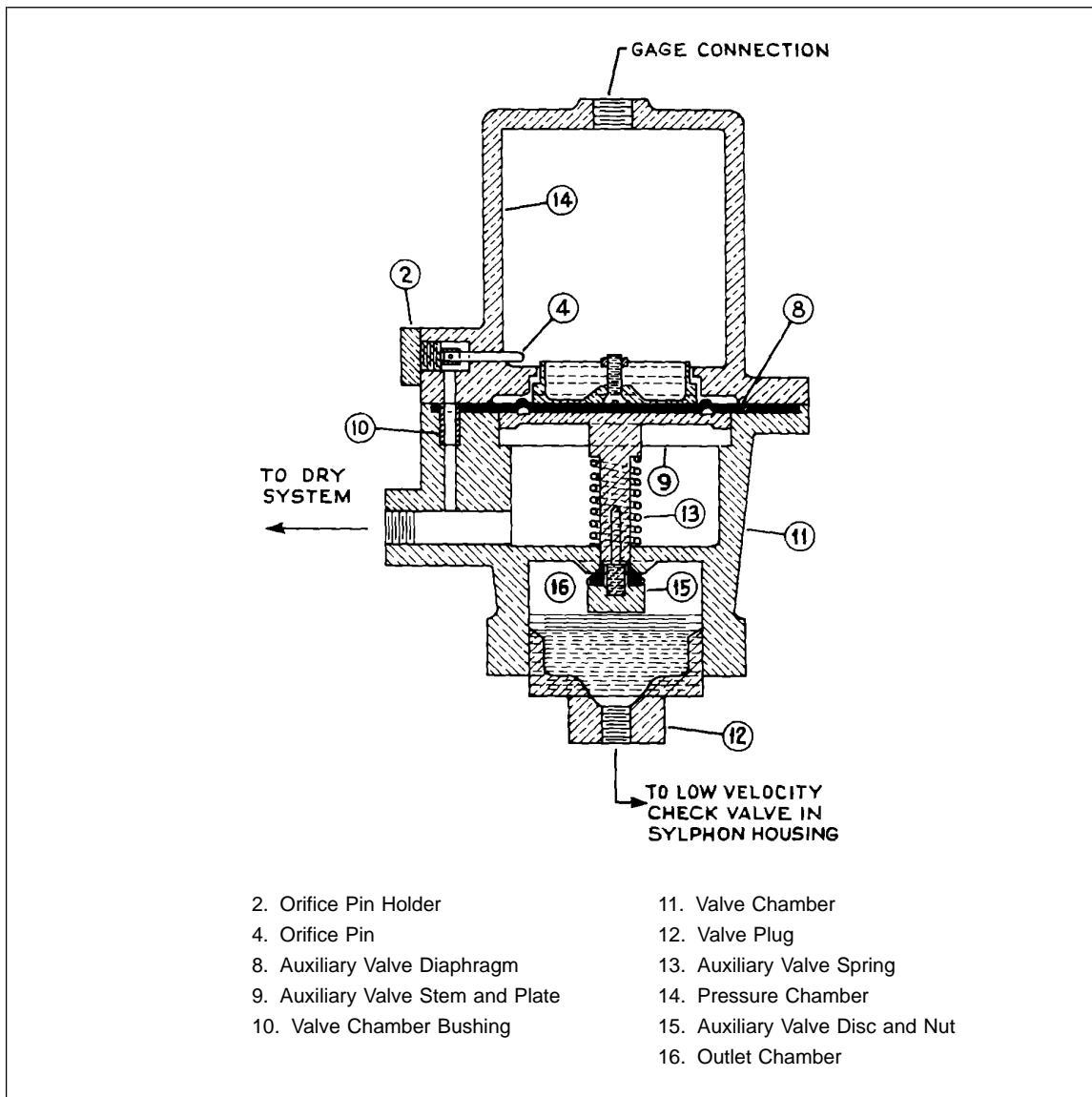

Fig. 112. Central Dry-Pipe Accelerator Model AD

DIRECTIONS FOR SETTING ACCELERATOR

Close main gate valve and set the dry-pipe valve as directed, leaving the 2-inch drain open.

Open the 1/4-inch accelerator supply valve, and accelerator will reset automatically taking several minutes for the pressure to equalize.

Close 2-inch drain, open main control gate valve under the dry-pipe valve, and make drain test.

Make sure low velocity check valve in the release housing of the dry-pipe valve operates freely.

Resetting Failure or Air Leakage

If the accelerator fails to reset or there are indications of air leakage at the low velocity check valve, do the following:

Close the 1/4-inch valve in the accelerator supply line and remove the accelerator from the line.

Remove orifice pin holder (2) and orifice pin (4); thoroughly clean and replace.

Remove plug (12); thoroughly clean auxiliary valve disc (15) and its seat. Replace plug (12).

Remove and clean strainer in 1/4-inch supply line. Then reassemble strainer.

Put the accelerator back into the line. Open the 1/4-inch valve in the accelerator supply line.

Return the accelerator to the manufacturer for repairs if it still cannot be reset satisfactorily. If it is removed, make sure that the 1/4-inch valve is tightly closed and the outlet in the adaptor at the bottom of the release housing on the dry-pipe valve is tightly plugged.

3.7 FPC Models A and B Accelerators

F.P.C. Accelerator

MODEL A 1924 To 1930 MODEL B 1930 To 1973

Fire Protection Co., Chicago, Ill.

DESCRIPTION (Fig. 113)

The F.P.C. accelerators Models A and B are similar and are designed for use with F.P.C. dry valves, but may be used with practically all types of differential valves. The Models A and B differ only in body design. In 1955, the Model B accelerator underwent body design changes. Otherwise, the accelerators are the same.

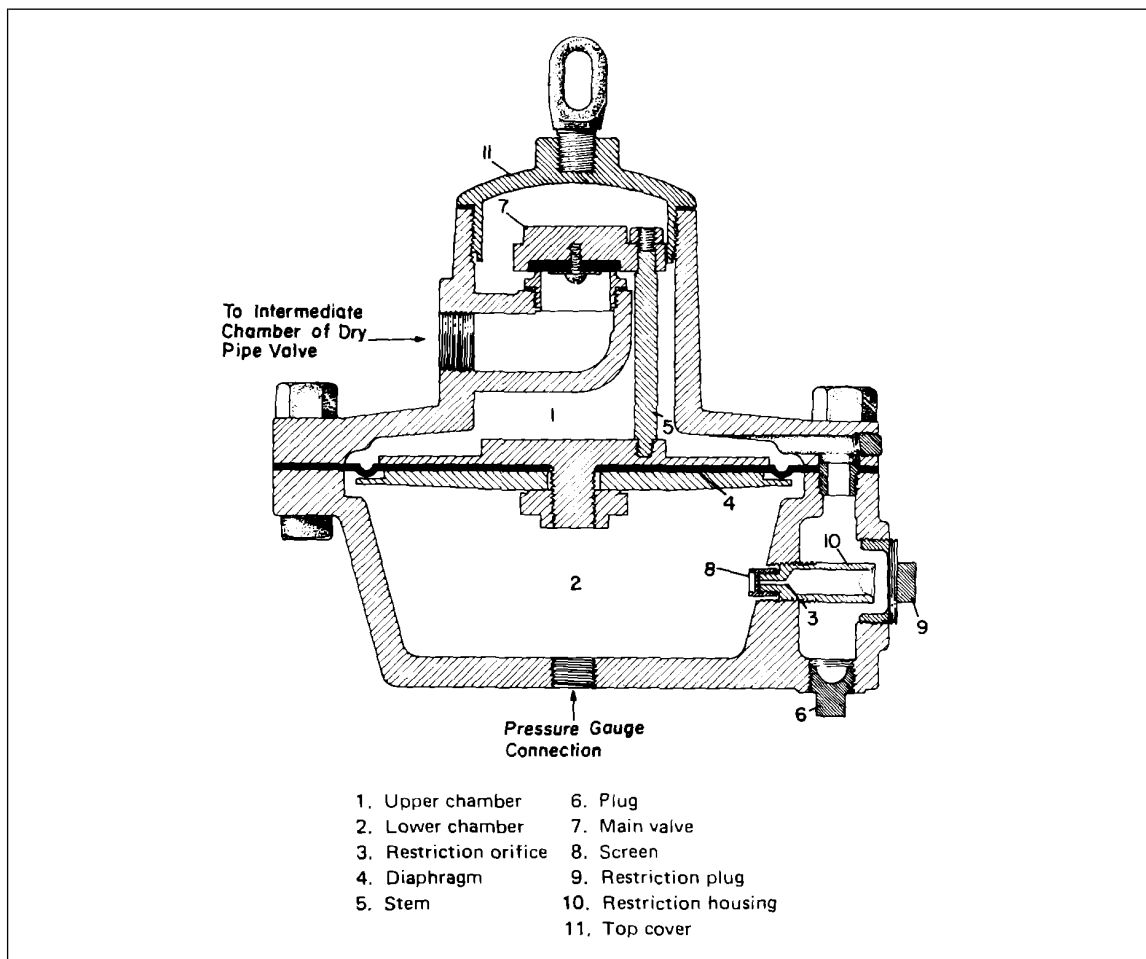

Fig. 113. F.P.C. Accelerator Model B, internal view (made after 1955).

Air pressure from the sprinkler system enters upper chamber 1 and passes to lower chamber 2 via restriction orifice 3. When sprinkler system pressure drops, pressure in upper chamber 1 also drops. Lower chamber 2 cannot relieve its pressure due to restriction orifice 3. This excess pressure forces diaphragm 4 and the

stems 5 up, forcing open main valve 7. Air pressure from the system passes through the accelerator to the intermediate chamber of the dry valve destroying its differential and causing the valve to operate.

INSPECTION

Refer to Fig. 113 and 114.

1. Check that air supply valve B is wide open.
2. Check that pressure gauge C indicates the same pressure as that in sprinkler system. If the pressures differ, increase sprinkler pressure a few pounds and note if pressure gauge C increases a similar amount. (This will take about 5 minutes.) If the pressure does not increase, restriction orifice 3 or screens 8 are probably plugged. Close air supply valve B and remove restriction plug 9. Remove restriction housing 10 and carefully clean restriction orifice 3 and screens 8. Replace restriction housing 10 and restriction plug 9, making sure all joints are tight. Open air supply valve B and note if pressure gauge C indicates the proper pressure. (This will take about 5 minutes.) If the orifice is still found obstructed, close air supply valve B and remove restriction housing 10 with screens 8 and send them to the manufacturer for repair. The accelerator will be out of service, but the dry valve will operate.
3. Check the level of priming water in the dry pipe valve. Priming water should never reach the level of air supply valve D.
4. Check that automatic drip valve D on the dry-pipe valve is open.
5. Check that air supply valve B is wide open.

TESTING

(Without Tripping Dry-Pipe Valve)

Refer to Fig. 113 and 114.

1. Close the main control valve.
2. Open main drain valve A.
3. Close air supply valve B.
4. Loosen plug 6. The accelerator should operate. Tighten plug 6 when finished. Loosen pressure gauge C connection to allow excess pressure to escape from lower chamber 2.
5. Close main drain valve A.
6. Follow steps 4 to 7 under **SETTING**.

SETTING

Refer to Fig. 113 and 114.

1. Close air supply valve B and set the dry-pipe valve, using the appropriate data sheet or manufacturer's instructions. Do not open the main control valve until later.
2. Drain the accelerator by removing pressure gauge C and plug 6. Replace tightly when finished.
3. Remove restriction plug 9 and restriction housing 10. Carefully clean restriction housing 10 which contains restriction orifice 3 and screens 8. Replace restriction housing 10 and restriction plug 9 making sure all joints are tight.
4. Open air supply valve B. Make sure main valve 7 is seated properly by listening for escaping air at the drip valve. (Make sure drip valve is open.) If air is leaking, close air supply valve B and remove top cover 11 of the accelerator to check the seating of main valve 7. Replace cover and repeat above procedure.
5. Observe if the pressure reading on gauge C is rising. It will take approximately 6 minutes to equal the reading of air pressure in the sprinkler system.
6. **Open wide the main control valve.**
7. Test the water supply by opening main drain valve A.

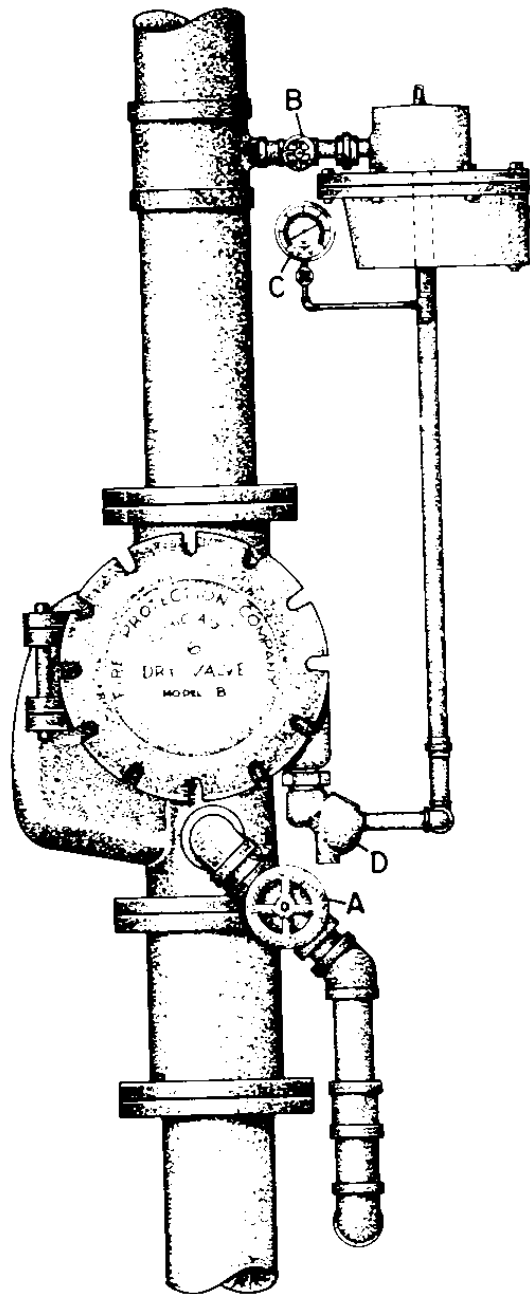

- A. Main Drain Valve
- B. Air Supply Valve
- C. Pressure Gauge
- D. Drip Valve

Fig. 114. F.P.C. Accelerator Model B trim.

3.8 Globe Model A Exhauster-Adapter

Globe Exhauster-Adapter MODEL A, 1927 TO 1929

Norris Industries, Fire And Safety Equipment Div., * Newark, N.J.

DESCRIPTION

The Model A exhauster-adapter (Fig.115) causes the Globe accelerator to act as an exhauster. The exhauster-adapter may be used with mechanical dry valves and those differential dry-valves having mechanical drip valves. The inlet end of the adapter is connected to sprinkler system air pressure as shown in Fig. 2. Between air supply valve A (Fig. 116) and the adapter, 1½-in. (13-mm) line containing a restriction orifice leads to the accelerator and the diaphragm side of the adapter. Air pressure from the sprinkler system passes through the orifice to the accelerator and adapter. Air pressure acting on diaphragm 1 holds valve 3 closed.

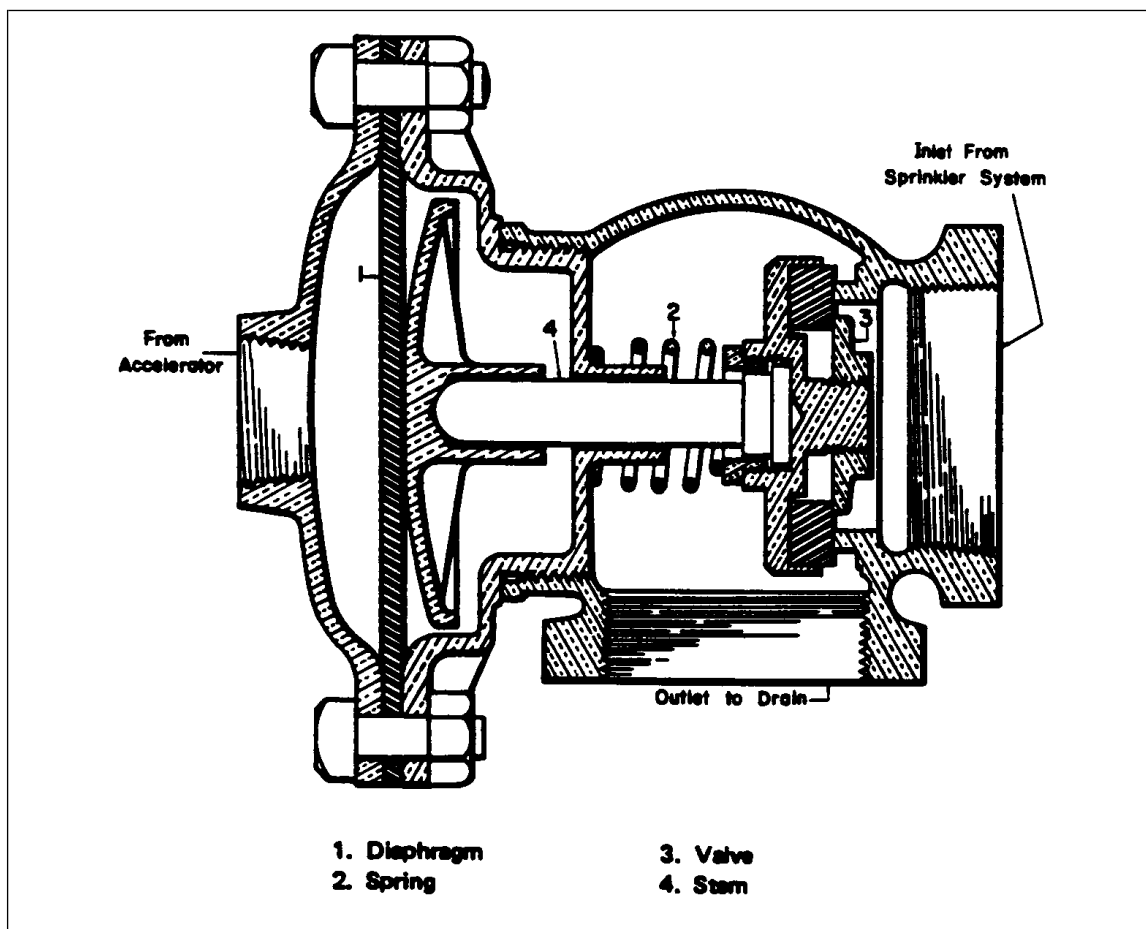

Fig. 115. Globe Model A exhauster-adapter, internal view.

When system pressure is reduced sufficiently, the accelerator will trip discharging air through the dry-pipe valve to atmosphere. This lowers the pressure at the adapter's diaphragm 1, allowing the exhauster-adapter to open.

Air pressure from the sprinkler system is exhausted to drain through the exhauster-adapter. When the dry-pipe valve operates, water enters the accelerator and adapter port preventing further waste of water.

INSPECTION

1. See directions for inspecting the accelerator. The condition of the exhauster-adapter cannot be readily discerned by inspection.

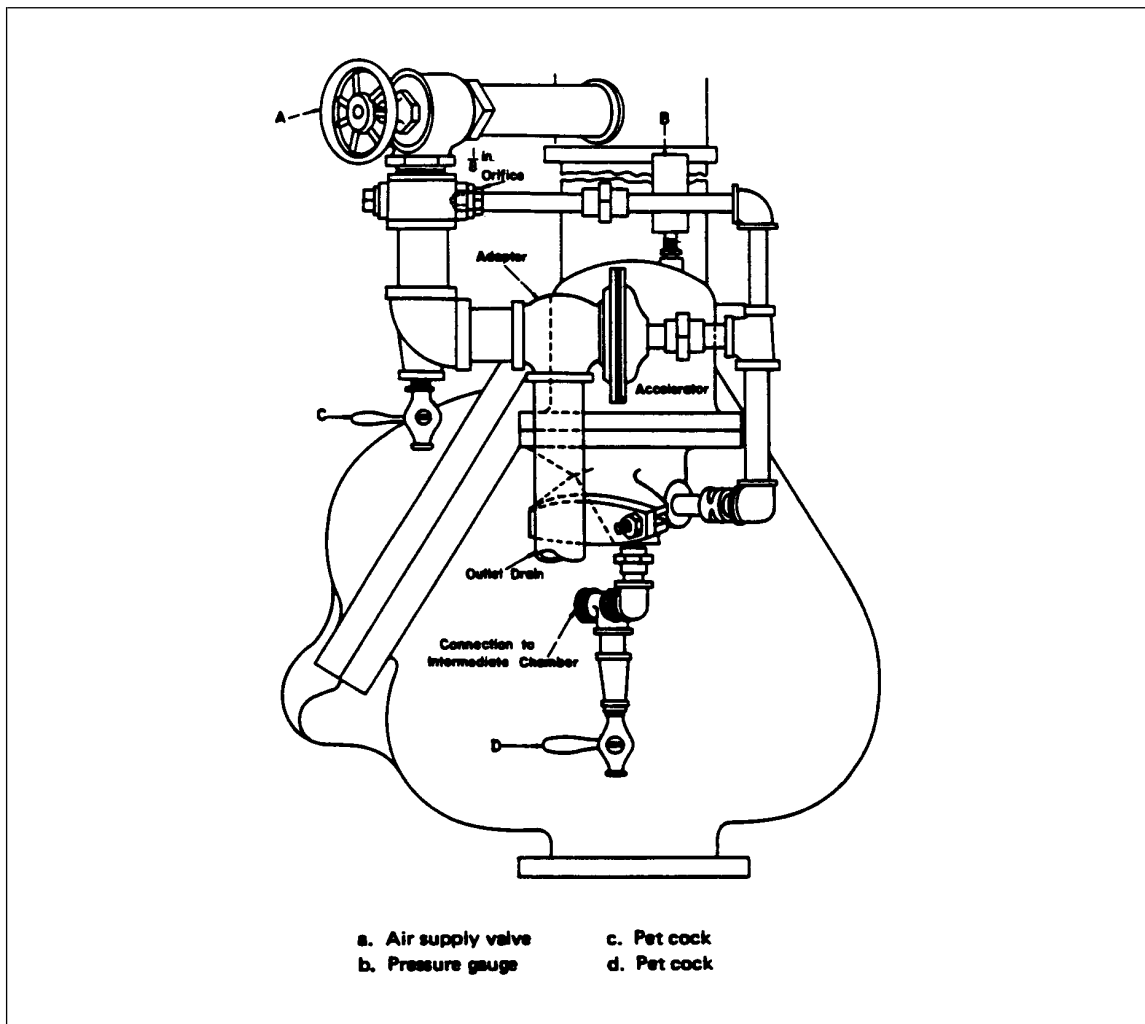

Fig. 116. Globe Model A exhauster-adapter trim.

*Formerly Fyr Fyter Co., Newark, N.J., and Globe Automatic Sprinkler Co., Philadelphia, Pa.

TESTING (Without Tripping Dry-Pipe Valve)

1. Close air supply valve A.
2. Close the main control valve supplying water to the system.
3. Open the main drain valve.
4. Open pet cock D. The accelerator and exhauster-adapter should operate. Close pet cock D tightly when finished.
5. Close the main drain valve.
6. Follow the procedure as outlined under SETTING to reset the exhauster-adapter.

SETTING

1. Close air supply valve A and set the dry-pipe valve and accelerator using the appropriate data sheet or manufacturer's instructions. Make sure pet cocks C and D are closed. The exhauster-adapter will reset with the accelerator.
2. Test the water supply by opening the main drain valve.

3.9 Globe Model B Exhauster

Globe Exhauster MODEL B 1929 TO 1972

Norris Industries, Fire Safety and Equipment Div.,* Newark, N.J.

DESCRIPTION

Globe Model B Exhauster (Fig. 117) is designed for use with the Model B dry-pipe valve, but may be used with practically all types of dry valves. Air pressure from the sprinkler system enters lower chamber 1 and travels through passage 4 to middle chamber 2 and upper chamber 3. In set position, air pressure in the three chambers is equal. Relief valve spring 7 holds auxiliary valve 9 closed, and exhaust valve spring 8 holds main valve (formerly known as air check valve) 10 closed.

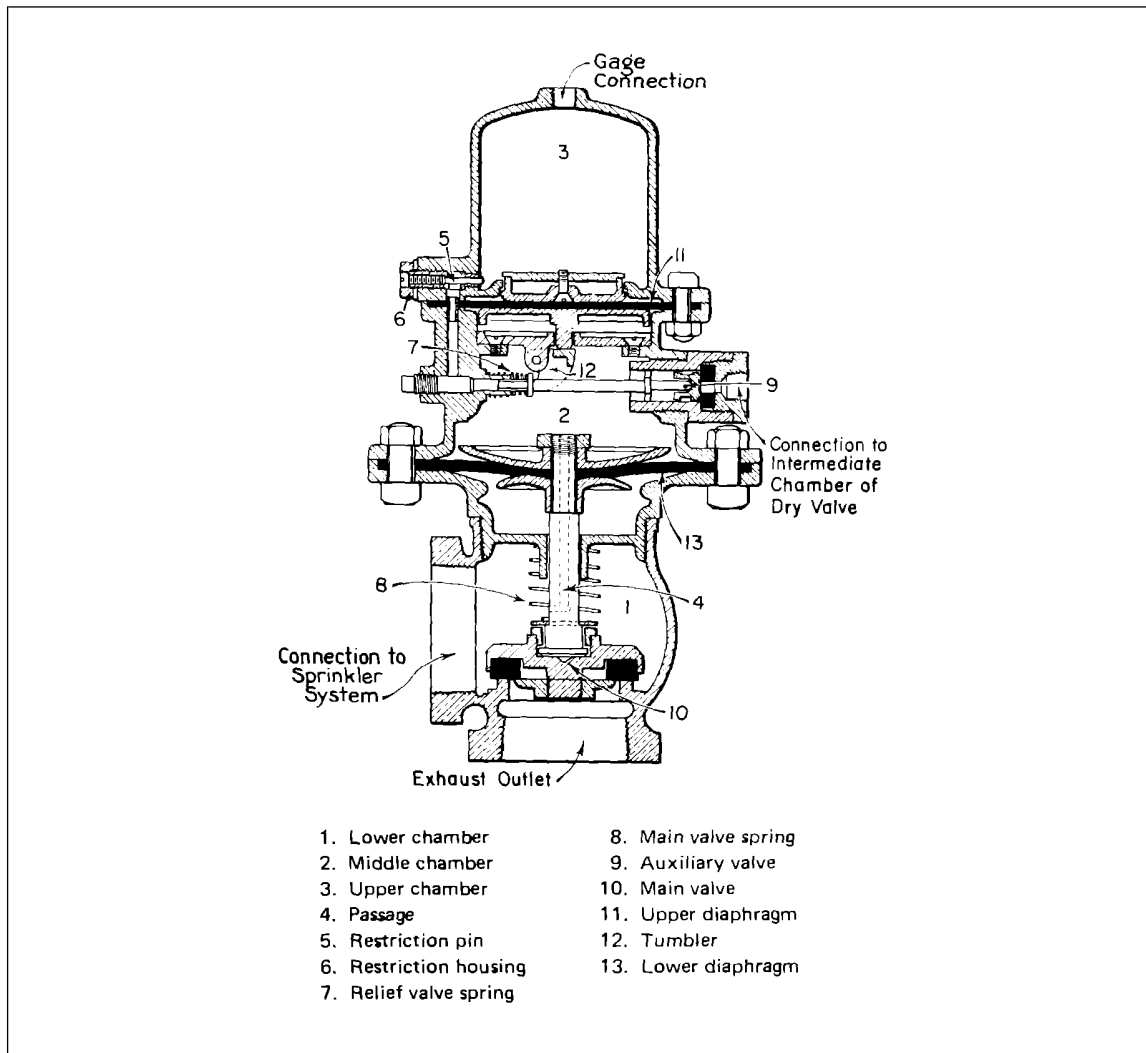

Fig. 117. Globe Model B exhauster, internal view.

When system air pressure is reduced sufficiently, pressure in lower chamber 1 and middle chamber 2 is also reduced. Upper chamber 3 cannot relieve its pressure as quickly due to restriction pin 5. The excess pressure forces upper diaphragm 11 down, making tumbler 12 force auxiliary valve 9 open. Middle chamber 2 can now exhaust its air pressure faster than lower chamber 1. The excess pressure in lower chamber 1 forces lower diaphragm 13 upward, opening main valve 10. Sprinkler system air pressure now passes through the exhauster to the outlet drain.

After the dry-pipe valve trips, water from the intermediate chamber of the dry valve enters middle chamber 2 of the exhauster. The pressure of the water, assisted by main valve spring 8, closes main valve 10 preventing waste of water through the outlet drain.

INSPECTION

1. Check that air supply valve B (Fig. 118) is wide open.

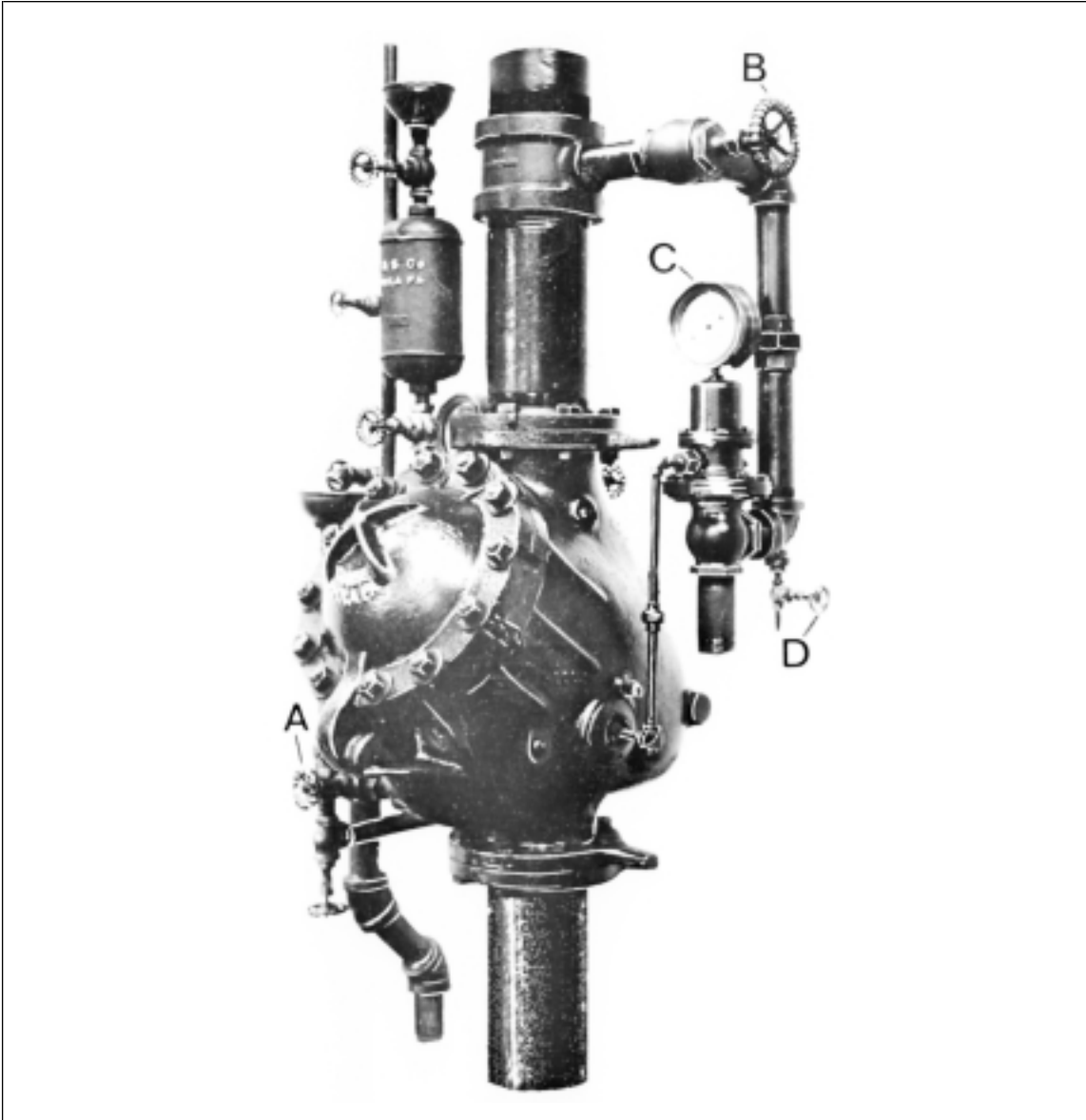

Fig. 118. Globe Model B exhauster trim.

2. Check that pressure gauge C indicates the same pressure as that in the sprinkler system. If the pressures differ increase sprinkler pressure a few pounds and check that pressure gauge C has increased a similar amount. (This will take about 10 minutes.) If the pressures still differ, restriction pin 5 is probably plugged. Close air supply valve B and remove restriction pin housing 6. Thoroughly clean restriction pin 5 and its bushing. Replace restriction pin housing 6, making sure the joint is tight. Open air supply valve B. Check pressure gauge C; it should slowly reach the same pressure as that in the sprinkler system. (This will take about 25 minutes.)

If the orifice is still plugged, close air supply valve B and send restriction pin housing 14 to the manufacturer for repair. The dry-pipe valve will still operate with the accelerator out of service.

3. Check the level of priming water in the dry valve. Priming water should never reach the level of air supply valve B. Slightly open test valve D and drain any accumulated water. Tightly close test valve D when finished.
4. Check that air supply valve B is wide open.

TESTING (without tripping dry valve)

1. Close the main control valve supplying water to the system.
2. Open main drain valve A.
3. Close air supply valve B.
4. Open test valve D and the exhauster should operate. Close test valve D when finished.
5. Close main drain valve A.
6. Follow steps 4 to 7 under **SETTING**.

SETTING

1. Close air supply valve B and set the dry valve using the appropriate data sheet or manufacturer's instruction. Do not open the main control valve until later.
2. Open test valve D and allow any accumulated water to drain. Close test valve D tightly when finished.
3. Remove restriction pin housing 6 (Fig. 117) and carefully clean restriction pin 5 and its bushing. Replace tightly when finished.
4. Open air supply valve B and note if air escapes past main valve 10. If air escapes, close air supply valve B and remove the discharge pipe from the exhauster. The main valve can now be opened manually and the seat cleaned with a cloth swab bent at right angles to the seat. Replace the discharge pipe and open air supply valve B.
5. Check that pressure reading on gauge C slowly rises to the same pressure as that in the sprinkler system. (This will take about 25 minutes.)
6. Open wide the main control valve.
7. Test the water supply by opening main drain valve A.

3.10 Globe Model B Accelerator

Globe Accelerator MODEL B, 1923 TO 1924

Norris Industries, Fire & Safety Equipment Div.^{*}, Newark, New Jersey

DESCRIPTION

Globe Model B accelerator (Fig. 119) is designed for use with differential or semimechanical dry-pipe valves. Air pressure from the sprinkler system enters lower chamber 1 and passes to upper chamber 2 via restriction orifice 3. In set condition, spring 8 holds diaphragm 9 up, allowing weight 6 to keep main valve 7 closed.

^{*}Formerly Fyr Fyter Co., Newark, N.J. and Globe Automatic Sprinkler Co., Philadelphia, Pa.

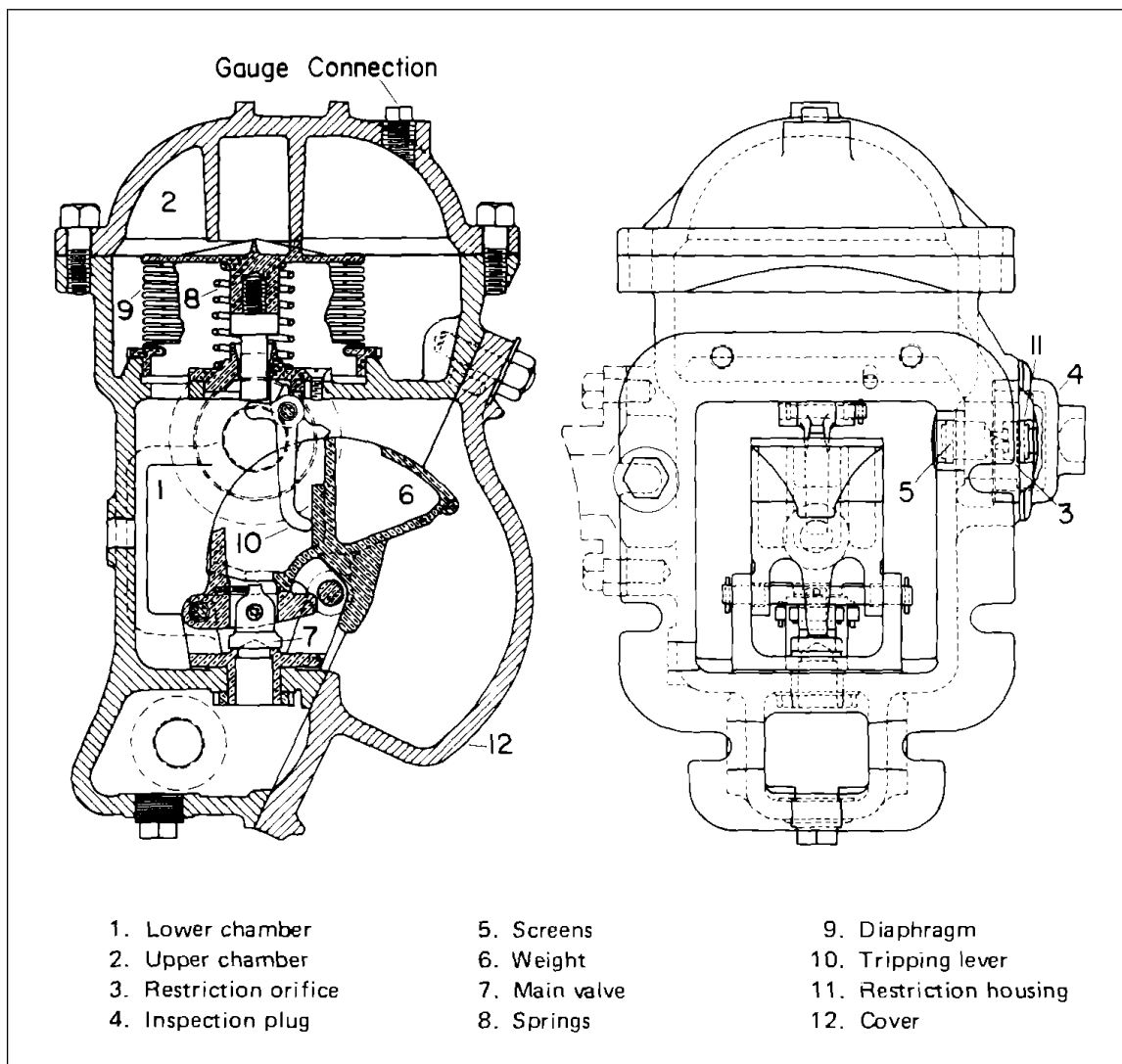

Fig. 119. Globe Model B accelerator, internal views.

When system air pressure is reduced sufficiently, lower chamber 1 also reduces its pressure. Upper chamber 2 cannot relieve its pressure as quickly, due to restriction orifice 3. The excess pressure forces diaphragm 9 down moving tripping lever 10 which pushes weight 6. Weight 6 drops, opening main valve 7. Air from the sprinkler system passes through the accelerator to the intermediate chamber of the dry valve destroying the differential and causing it to operate.

INSPECTION

1. Check that air supply valve C (Fig. 120) is wide open.
2. Check that pressure gauge C indicates the same pressure as that in the sprinkler system. If the pressures differ, increase sprinkler pressure a few pounds and note if the pressure on gauge C increases a similar amount. (This will take about 10 minutes.) If the pressure on gauge C does not increase, restriction orifice 3 and screens 5 are probably plugged. Close air supply valve B and remove inspection plug 4. Remove restriction housing 11 and carefully clean restriction orifice 3 and screens 5, replacing restriction housing 11 tightly when finished. Replace inspection plug 4 and open air supply valve B. Check that pressure gauge C indicates the same pressure as that in the sprinkler system. (This will take about 15 minutes.) If restriction orifice 3 is still plugged, the accelerator should be replaced with a FM Approved accelerator.

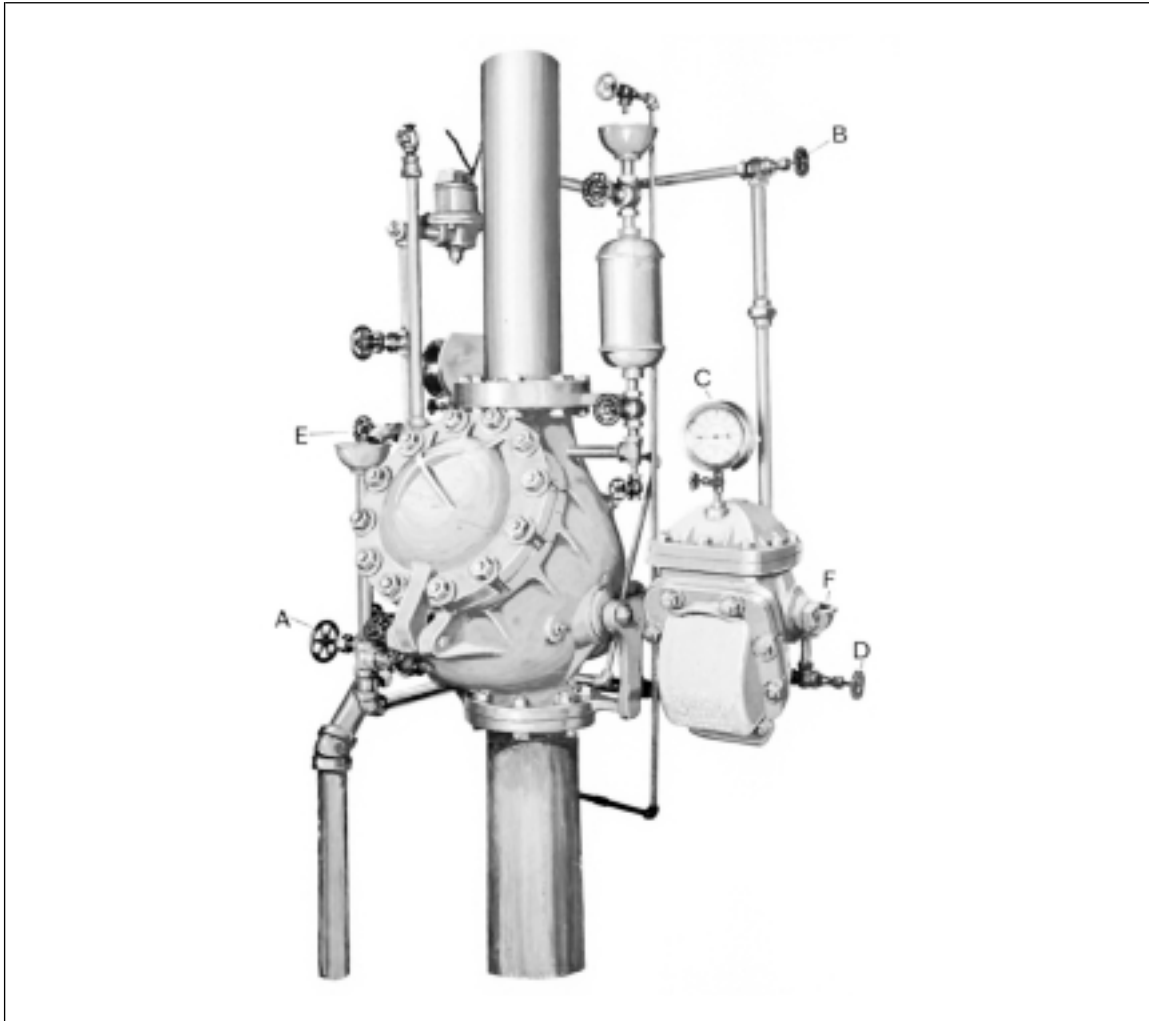

Fig. 120. Globe Model B accelerator trim.

3. Check the level of priming water in the dry-pipe valve by opening test valve E. Priming water should never reach the level of air supply valve C. Open accelerator test valve D **slightly** until escaping air indicates the priming water level for main valve 7 is at the proper level.

4. Check that the ball drip on the dry valve is open and free to move.

5. Check that air supply valve B is open.

TESTING (Without Tripping Valve)

1. Close the main control valve supplying water to the system.

2. Open main drain valve A.

3. Close air supply valve B.

4. Open accelerator test valve D and the accelerator should operate. Close tightly when finished.

5. Close main drain valve A.

6. Follow steps 6 to 10 under **SETTING** for resetting the accelerator.

SETTING

1. Close air supply valve B and set the dry-pipe valve following procedures in the appropriate data sheet or manufacturer's instructions. Do not open the main control valve until later.

2. Remove cover 12 allowing weight 6 to drop and water to drain from the accelerator. Check the accelerator for any dirt and scale; clean if any exists.
3. Remove inspection plug 4 and restriction housing 11. Carefully clean restriction orifice 3 and screens 5. Replace the assembly when finished, tightening all joints.
4. Clean main valve 7 and its seats; then lift weight 6 to the vertical position (Fig. 119).
5. Replace cover 12.
6. Open test valve D and pour water into priming cup F until water remains. Close test valve D when finished.
7. Open air supply valve B and check the ball drip on the dry valve for any escaping air. If air is escaping, close air supply valve B and thoroughly clean main valve 7.
8. Check that the reading on pressure gauge C slowly rises to indicate the same pressure as that in the sprinkler system. (This will take about 15 minutes.)
9. **Open wide the main control valve.**
10. Test the water supply by opening main drain valve A.

3.11 Globe Model B Electroac Valve

Dry-Pipe Electroac Valve – “Globe” Model B

GLOBE MODEL B-ELECTROAC VALVE (Quick-Opening Device)

The Globe Model B Electroac Valve is designed to accelerate the tripping of the Globe Model D dry pipe valves only. It consists essentially of a specially designed mercury switch connected to the sprinkler piping through ¼ in. copper tubing, and operating a solenoid-operated valve E installed in the air bypass valve assembly 6 (Figs. 121 and 122). Current for the solenoid is from an outside source through a transformer. Whenever the drop in system air pressure exceeds a predetermined rate, the mercury switch closes the circuit to solenoid E which opens and causes the dry pipe valve to trip (Fig. 121). A small pressure tank is installed in the air line to prevent water entering the mercury switch when the dry pipe valve trips. The transformer, mercury switch, and pressure tank are all contained in a steel box (Electroac Control Station L) mounted on the sprinkler riser (See Fig. 122).

MERCURY SWITCH

The mercury switch (Fig. 123), which is the main element of the quick-opening unit, consists of three chambers, namely: switch chamber (15), overflow chamber (17), and air storage chamber (19), formed within cylindrical molded resin base (1), inner casing (3), and outer casing (2) which are interconnected by unequally sized orifices (14), (16), (18), and (20). The air storage chamber is formed by a space between the inner and outer casings. The switch chamber is a 1/16 in. deep by 1/8 in. wide groove in the vertical cylinder part of the base (1) and the overflow chamber is a segment of a circular shaped opening in the vertical cylinder part of the base (1). The bottom of the overflow chamber is higher than the bottoms of the other two chambers.

Two stainless steel contact rings (9) connected to the switch chamber by pins (13) surround the inner casing. Two stainless steel contact plates (8) make contact between the contact rings and the contact plate screws (7), connecting terminal wires leading to the solenoid valve (E). The orifices connecting the bottoms of the three chambers are sealed with mercury up to the center of the lower contact ring.

OPERATION

When the device is in the set position, system air pressure equalizes in the switch and overflow chambers but is slightly less in the air storage chamber due to the difference in mercury head. When system air pressure drops in excess of a predetermined rate, the pressure drops in the switch and overflow chambers at equal rates, leaving a higher pressure in the air storage chamber because of the smaller orifice. This difference in pressure forces the mercury seal from the storage chamber into the overflow and switch chambers; but because orifice (20) connecting the storage and switch chambers is larger than orifice (18) connecting the storage and overflow chambers, mercury rises at a higher rate in the switch chamber submerging the pins (13). When the pins are submerged, the electrical circuit to the solenoid (E) is completed - which opens Electroac valve (F) and by-passes system air pressure behind the release bellows at the dry pipe valve neutralizing pressure in the release sleeve, thereby tripping the dry pipe valve. (See Data Sheet 26.32). When system pressure is reduced slowly, as from a piping leak, the rate of pressure reduction in the chambers

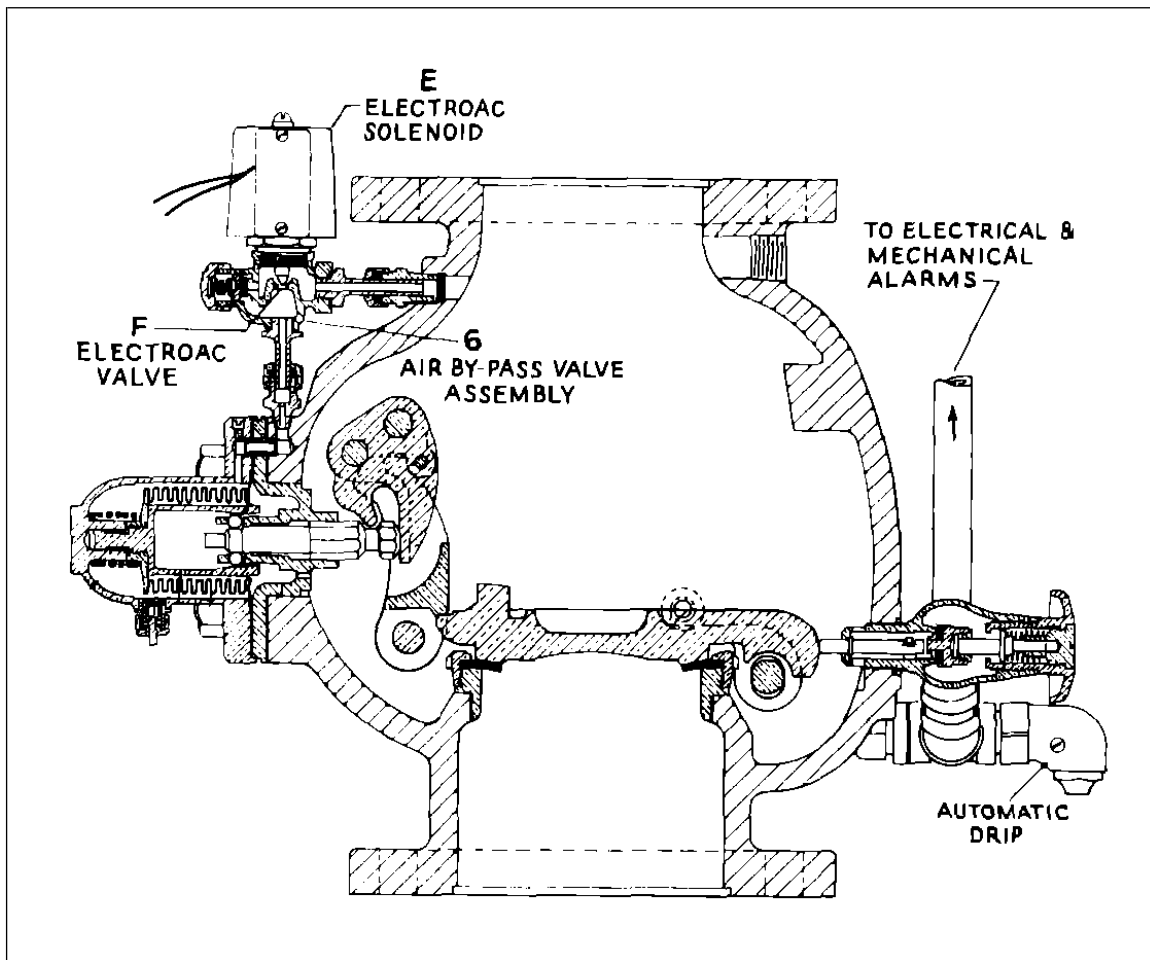

Fig. 121. Globe Electroac Quick-Opening Device showing Solenoid E and Air By-Pass Valve Assembly (6) with Globe Model D Dry Pipe Valve.

will be correspondingly slow and because of unequal sized orifices, the greater proportion of mercury will enter the overflow chamber, leaving insufficient mercury to submerge the pins in the switch chamber, thereby preventing premature tripping of the dry pipe valve.

The quick-opening device resets automatically.

Water in the pressure tank will drain out automatically through the system drain connections when the latter are opened.

TESTING

The quick-opening device can be tested only by trip testing the dry pipe valve.

Should it be desirable to trip test the dry pipe valve without operating the quick opening device, disconnect a lead wire at the solenoid valve (E).

PRECAUTIONS

When making water column tests at dry pipe valves equipped with quick-opening devices, care should be exercised to reduce air system pressure at a lesser rate than the predetermined rate of the quick-opening device to prevent accidental tripping of the dry pipe valve.

Should the solenoid valve require maintenance service, it can be removed separately from the air by-pass valve which should not be removed unless absolutely necessary since without it, the bellows in the mechanical release might be damaged by high unbalanced water pressure should the valve trip.

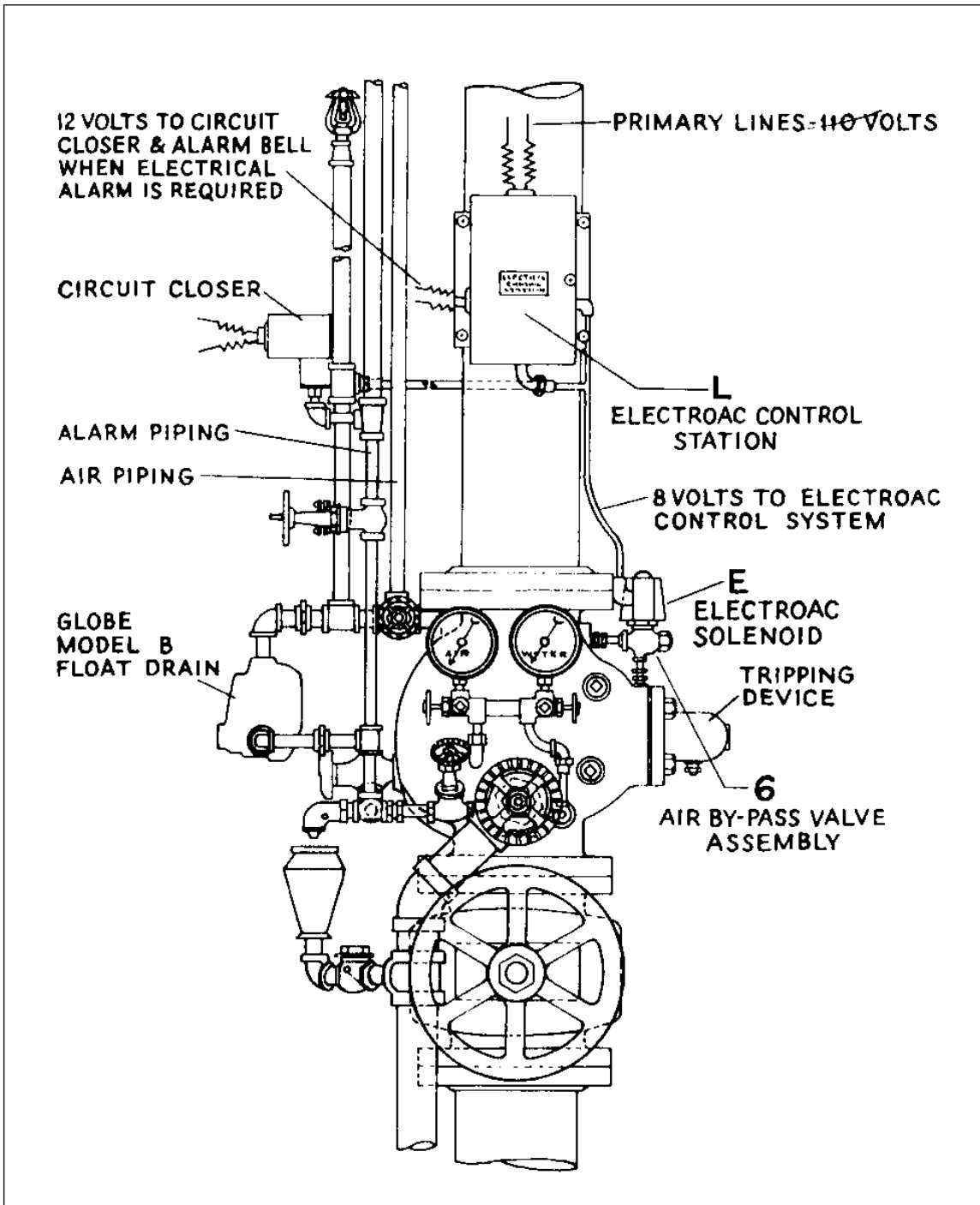

Fig. 122. Model B Electroac Valve attached to Globe D Dry Pipe Valve.

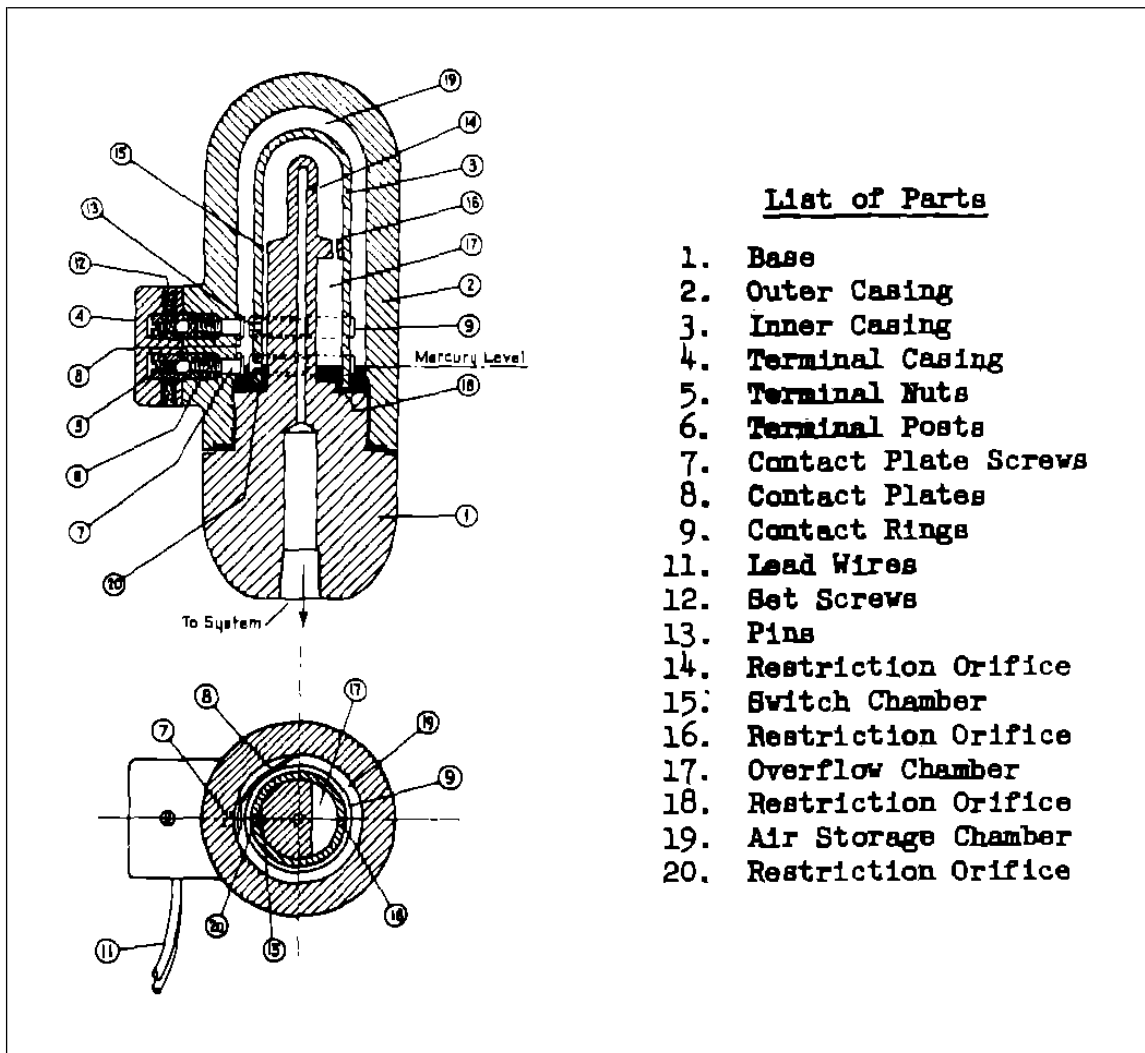

Fig. 123. Mercury Switch.

3.12 Globe Model C Quick-Opening Device

Globe Dry-Pipe Quick Opening Device - Model C (Formerly called Accelerator Model E and Exhauster Model C) 1934 TO DATE

Globe Automatic Sprinkler Co., Inc., Philadelphia, Pa.

Used with Model C, Model AD and Model F dry-pipe valves. Can also be used with Model D dry-pipe valve in place of "Electroac" quick-opening device).

DESCRIPTION

This device consists of a bronze body in two parts containing an upper chamber (1), and a lower chamber (2), which are connected by the hollow central stem of pressure plate (3). A restricted orifice pin (13) loosely fitted into the hollow central stem, provides a restriction. A diaphragm (11), clamped between pressure plate (3) and diaphragm plate (4), is held in position at the rim by clamping ring (10). The lower end of the hollow central stem of pressure plate (3) rests over a hole in the center of disc container (15), which holds valve disc (14). A hollow centered retaining screw (16) holds the restricted orifice pin (13) in place in the hole in the center of disc container (15). Spring (19) holds valve disc (14) on its seat. Cap (20) holds the spring (19) in

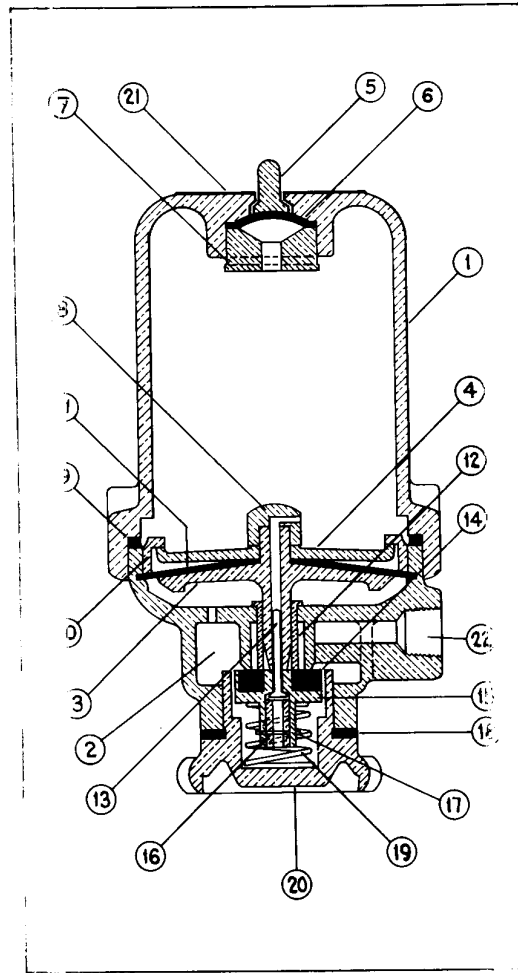

- | | |
|--------------------|----------------------------|
| 1. Upper Chamber | 12. Valve Seat |
| 2. Lower Chamber | 13. Restricted Orifice Pin |
| 3. Pressure Plate | 14. Valve Disc |
| 4. Diaphragm Plate | 15. Disc Container |
| 5. Plunger | 16. Retaining Screw |
| 6. Diaphragm | 17. Spring Retainer Disc |
| 7. Retaining Ring | 18. Gasket |
| 8. Nut | 19. Spring |
| 9. Gasket | 20. Cap |
| 10. Clamping Ring | 21. Nameplate |
| 11. Diaphragm | 22. Discharge Port |

Fig. 124. Globe Dry-Pipe Quick Opening Device - Model C

place and provides a means for draining and removal of parts for cleaning. Plunger (5) protrudes above the name plate (21) when air pressure enters the upper chamber indicating equalized pressures. This takes the place of a gage usually provided for this purpose.

OPERATION

When the dry-pipe valve is set, the system pressure is communicated to lower chamber (2) up through restricted orifice in the hollow central stem of pressure plate (3) to upper chamber (1) where it equalizes slowly. When loss of system air pressure exceeds a predetermined rate, the pressures in the two chambers become unbalanced. Because of the restricted orifice, the upper chamber retains the higher pressure which forces diaphragm assembly (4), (3), and (11) to deflect downward thus opening valve disc (14), allowing system air pressure to discharge through port (22).

With Model C, Model D and Model AD dry-pipe valves, the system air is discharged to the inside of the tripping device housing (See section 2.8 equalizing the pressure on both sides of the slyphon bellows causing the release mechanism to allow the dry-pipe valve to trip.

With the Model F dry-pipe valve (See section 2.8), the system air pressure is discharged to the intermediate chamber, destroying the differential and causing the valve to trip before the pressure in the system has fallen to the normal trip-point of the dry-pipe valve.

DIRECTIONS FOR INSPECTING

1. Make sure the valve on the supply pipe from the sprinkler system to the quick-opening device is normally kept wide open.
2. Observe that plunger (5) at top of device protrudes above nameplate (21).

DIRECTIONS FOR RESETTNG

1. Close the valve on the supply line from system to the quick-opening device.
2. Remove cap (20), valve disc container (15), and restricted orifice pin (13) for examination. Allow water to drain off.
3. Clean all parts if necessary, and replace.
4. Replace and hand tighten cap (20).
5. Open control valve on supply line from system to the quick-opening device. Air pressure in both chambers should equalize in approximately 6-3/4 minutes at 15 psi.

DIRECTIONS FOR TESTING

The quick-opening device should be tested by trip testing the dry-pipe valve. Follow instructions for trip testing dry-pipe valves as outlined under section 2.8.

GLOBE DRY-PIPE ACCELERATOR - MODEL C 1924-1926

Globe Automatic Sprinkler Co., Inc., Philadelphia, Pa.

When attached to Model B dry-pipe valve, connections are similar in all details to those used with Globe Accelerator Model D.

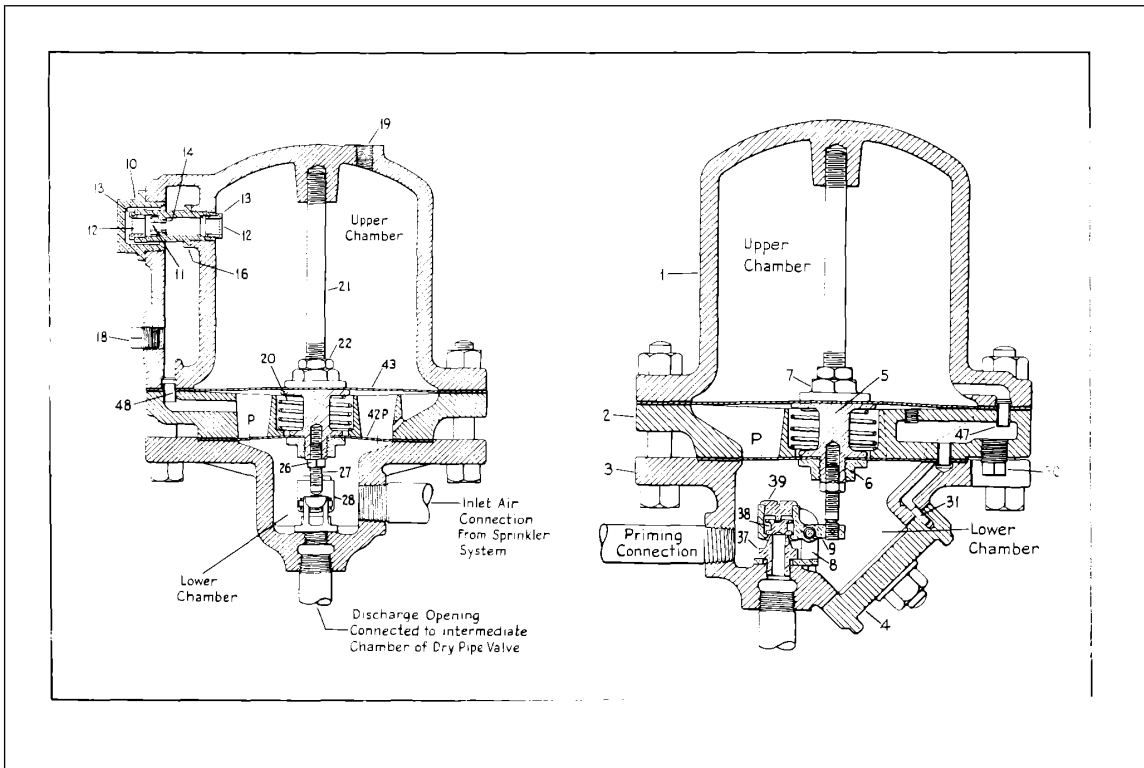

Fig. 125. Globe dry-pipe accelerator - Model C

- | | | |
|------------------------------|----------------------------------|----------------------------------|
| 1. Upper chamber | 11. Platinum eye or orifice | 27. Adjusting screw |
| 2. Spacer | 12. Monel strainer screens | 28. Pin |
| 3. Lower chamber | 13. Screen plugs | 31. Front cover pin |
| 4. Front cover | 14. Restricted orifice bushing | 37. Plunger seat |
| 5. Diaphragm spacer | 16. Restricted orifice container | 38. Plunger |
| 6. Spacer nut | 19. 1/4-in. gage connection | 39. Valve lever plug |
| 7. Diaphragm stop nut | 20. Diaphragm spring | 42. Lower diaphragm |
| 8. Valve lever bracket | 21. Diaphragm stop rod | 43. Upper diaphragm |
| 9. Valve lever | 22. Check nut | 47. Bronze bushed drain passages |
| 10. Strainer inspection plug | 26. Check nut | |

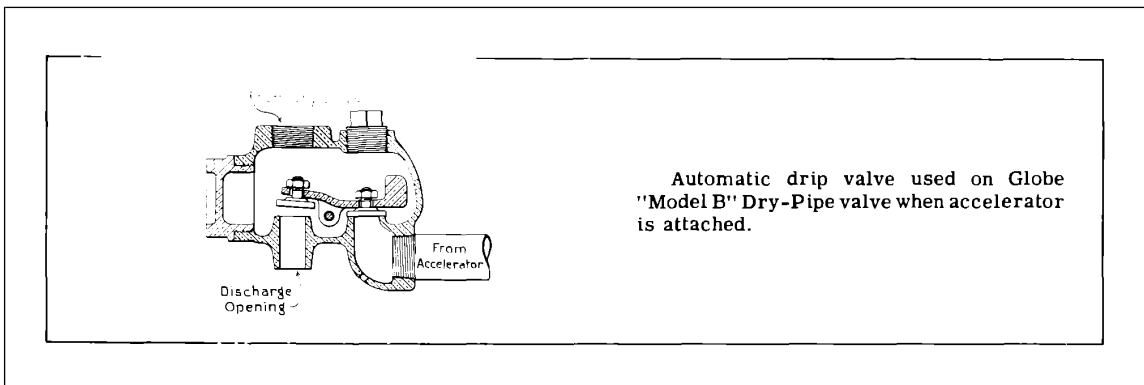

Fig. 126. Automatic drip valve

3.13 Globe Model D Accelerator

Globe Accelerator MODEL D, 1926 TO 1927

Norris Industries, Fire & Safety Equipment Div., Newark, N.J.

*Formerly Globe Automatic Sprinkler Co., Philadelphia, Pa.

DESCRIPTION

The Globe Model D accelerator (Fig. 127-A and B) can be used with practically all types of differential dry-pipe valves. Air pressure from the sprinkler system enters lower chamber 1 and upper chamber 2 via restriction orifice 3. Pressure in the two chambers is equalized and plunger 7 holds plunger valve 12 closed.

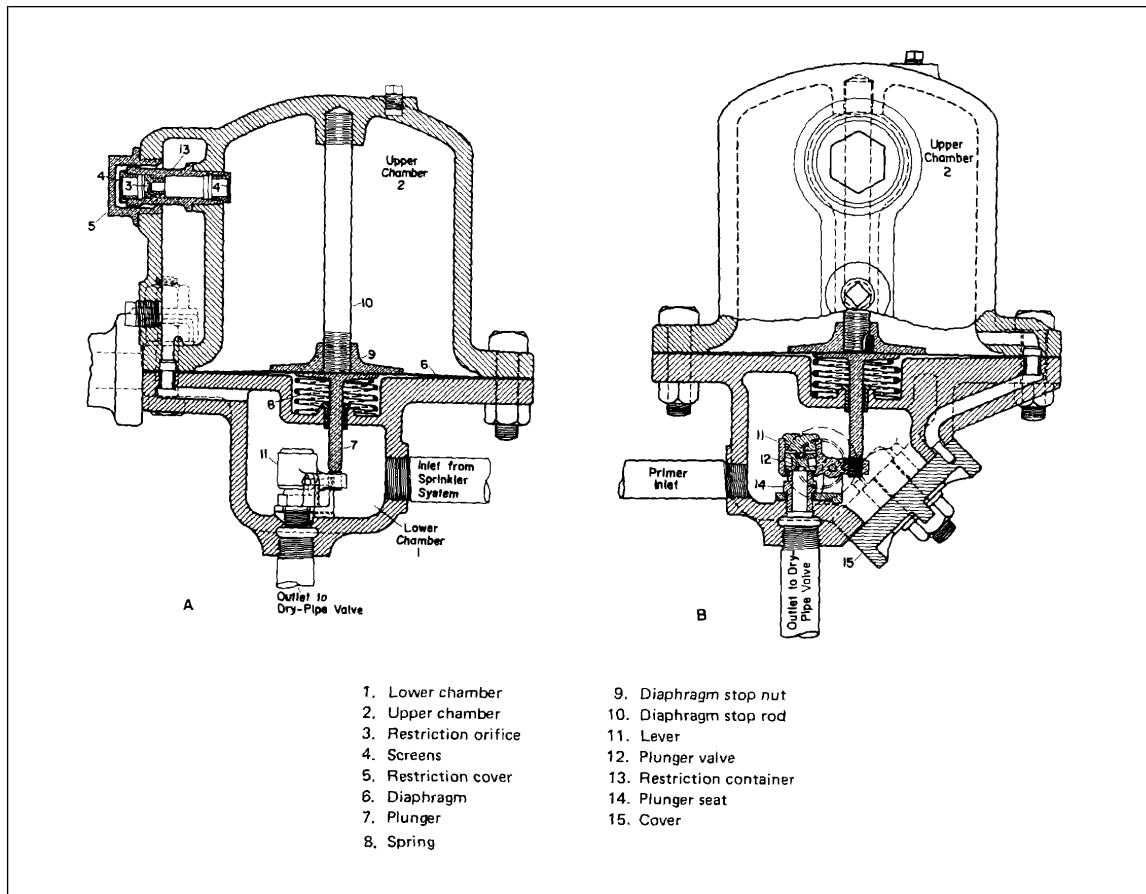

Fig. 127. Globe accelerator Model D. A, side view; B, front view.

When sprinkler system pressure is decreased rapidly, pressure in lower chamber 1 is also decreased. Upper chamber 2 cannot relieve its pressure as quickly, due to restriction orifice 3. The excess pressure forces diaphragm 6 and plunger 7 downward, opening plunger valve 12. Air from the sprinkler system passes through the accelerator to the intermediate chamber of the dry-pipe valve, destroying its differential and causing the dry valve to operate.

INSPECTION

1. Check air supply valve C (Fig. 128). It should be wide open.
2. Check that pressure gauge D indicates the same pressure as that in the sprinkler system. If the pressures differ, increase the sprinkler pressure a few pounds and note if pressure gauge D increases a similar amount. (This will take about 10 min.). If it does not increase, restriction orifice 3 or screens 4 are plugged and require cleaning. Close air supply valve C and remove restriction cover 5 and restriction container 13. Remove

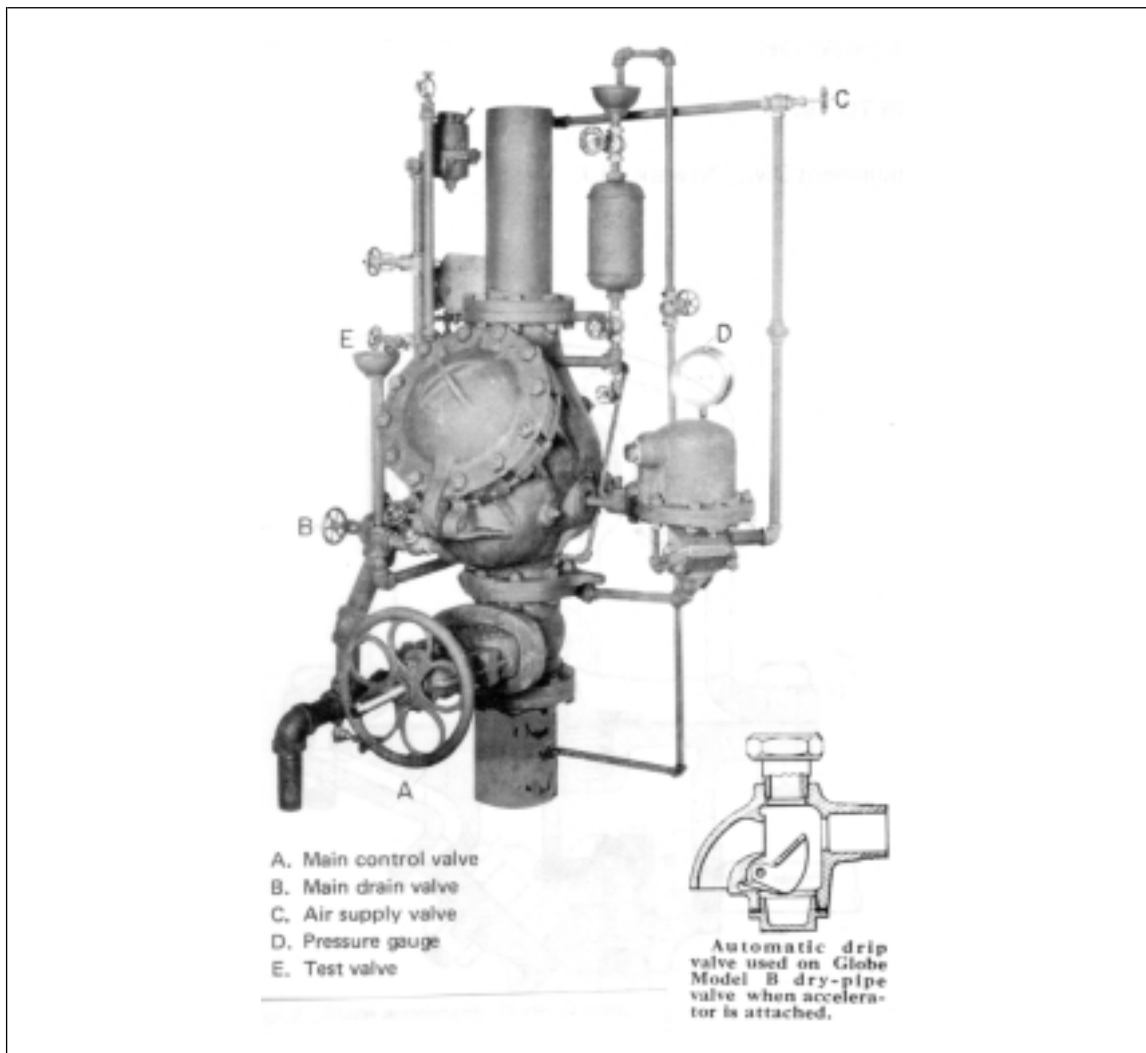

Fig. 128. Globe accelerator Model D trim.

screens 4 and carefully clean them and restriction orifice 3. Replace screens 4 and restriction container 13, making sure the joint is tight. Replace restriction cover 5 and open air supply valve C. Check pressure gauge D. If restriction orifice 3 is still plugged, restriction container 13, including screens 4, should be sent to the manufacturer for repairs. The dry-pipe valve will operate with the accelerator out of service.

3. Open test valve E slightly; if any water appears, draw it off to prevent any accumulation in the dry valve from reaching the level of air supply valve C. Close tightly when finished.

4. Check that plunger seat 14 is primed with water to prevent air leakage to the intermediate chamber of the dry valve. Open priming valve B (Fig. 129), and pour water into the accelerator priming cup until the cup remains full. Close priming valve B.

5. Check special automatic drip valve (Fig. 128) on the dry valve to make sure it is open and free to move. To determine if it is open, insert a pencil or other small object into the discharge opening of the drip valve. If the drip valve is left seated when the system is under air pressure, water could possibly leak pass the water seats of the dry valve and remain in the intermediate chamber. Eventually the differential would be destroyed and the valve would trip.

6. Make sure air supply valve C is open wide.

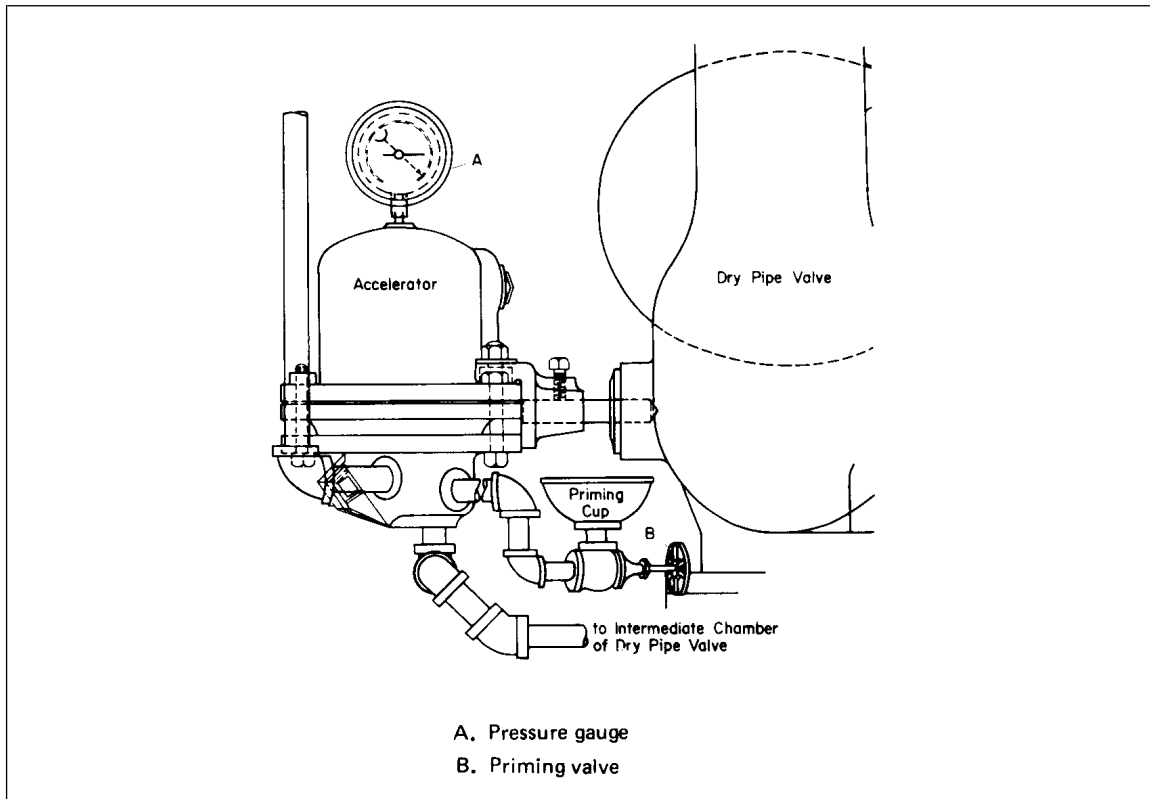

Fig. 129. Close-up of accelerator, priming cup, and priming valve.

TESTING (Without Tripping Dry Valve)

1. Close air supply valve C.
2. Close main control valve A.
3. Open main drain valve B.
4. Open priming valve B (Fig. 129), which will drop the pressure in the accelerator and cause it to operate. Close priming valve B.
5. Close main drain valve B (Fig. 128).
6. Follow steps 6 to 10 outlined under **Setting**.

SETTING

1. Close air supply valve C and set the dry-pipe valve, using the appropriate data sheet or manufacturer's instructions. Do not open main control valve A yet.
2. Remove cover 15 allowing water to drain.
3. Clean lower chamber 1 of all sediment and scale, paying particular attention to plunger valve 12 and plunger seat 14.

CAUTION: The accelerator should never be set without cleaning the plunger and its seat because sediment or foreign material at these points will cause leakage when they are subjected to air pressure.

4. Remove restriction cover 5 and restriction container 13. Carefully wash screens 4 and restriction orifice 3. Replace restriction container 13 and restriction cover 5. Make sure restriction container 13 is replaced with a tight joint because any leakage would retard operation of the accelerator.
5. Replace cover 15.

6. Open priming valve B (Fig. 129) and pour water into the accelerator priming cup until the priming cup remains full. Close priming valve B.
 7. Open air supply valve C (Fig. 128) and note if any air is leaking from the drip valve. If no air is leaking, plunger valve 12 is properly seated.
 8. Check that pressure gauge A (Fig. 129) slowly rises to indicate the same pressure reading as that in the sprinkler system.
- 9. Open wide main control valve A.**
10. Test the water supply by opening main drain valve B.

3.14 Grimes Model AB Accelerator

Grimes Dry-Pipe Accelerator MODEL AB 1957 TO DATE

Raisler Corp., New York, N.Y. 10017

DESCRIPTION

The Grimes Model AB accelerator (Fig. 130) is quite similar in design to the Model A accelerator which it replaces. Major design changes are: filter felts; adjustable extension lever arm; chamber sizes are smaller; valve seats are replaceable; pressure chamber 1 and body 2 are now bolted together; and an opening is provided to facilitate cleaning and servicing.

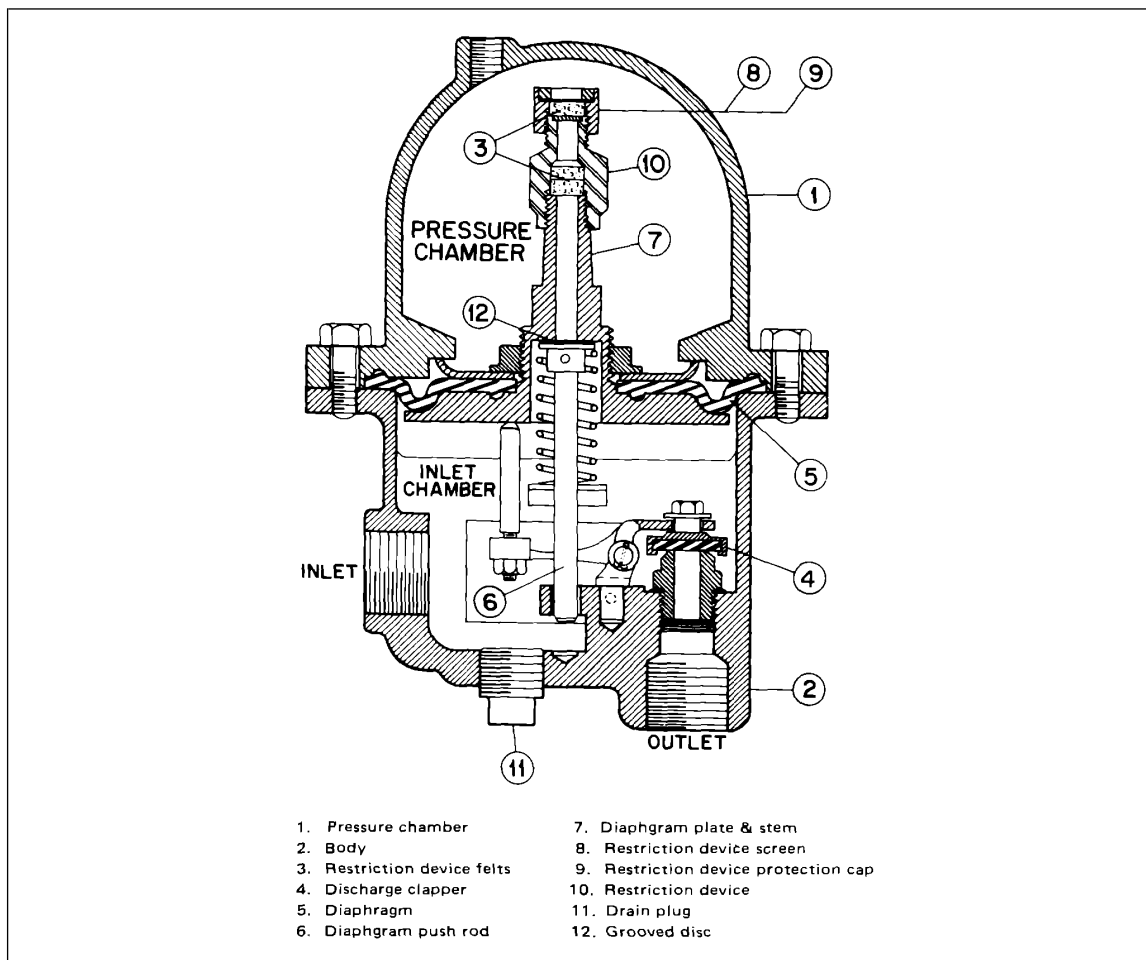

Fig. 130. Grimes Model AB dry-pipe accelerator.

Basically, the accelerator consists of a two-piece bronze housing bolted together. The housing is divided into pressure and inlet chambers by diaphragm 5. The discharge valve mechanism, centrally located, extends into both chambers separating the inlet and pressure chamber by its diaphragm 5, and closing the outlet port by its valve seat and discharge clapper 4. The restriction device 10 provides an air equalization passage between the pressure and inlet chambers.

OPERATION

System air pressure enters the inlet chamber of the accelerator through a pipe connection. It passes from the inlet chamber to the pressure chamber through the restriction device 10 and eventually establishes full system pressure in the pressure chamber. This passage of air is allowed by a grooved disc 12. Subsequent slight variations in the pressure between the two chambers of the accelerator are equalized by flow of air in one direction or the other through the restriction device 10.

Opening of an automatic sprinkler produces a drop in pressure on the system piping. This is accompanied by similar drop in the inlet chamber of the accelerator. A difference of pressure between the inlet and pressure chambers is established. The higher pressure in the pressure chamber acts on the diaphragm 18 and moves the diaphragm and parts attached to it in a downward direction causing the discharge clapper 4 to open.

The system air under pressure then passes through the connecting pipe to the intermediate chamber of the dry-pipe valve, closing the mechanical drip valve, and establishing system pressure in the intermediate chamber. This equalizes the pressure on both sides of the air clapper of the dry-pipe valve, with resulting tripping of the valve.

SETTING

1. Close accelerator inlet valve.
2. Remove drain plug 11. Allow all water to drain out.
3. Replace drain plug 11.
4. Set dry-pipe valve and restore air pressure to sprinkler system.
5. Open accelerator inlet valve. Pressure in the two chambers will now equalize (taking several minutes) with the pressure in the sprinkler system. The accelerator is now in operation.

TESTING

The accelerator may be tested without tripping the dry-pipe valve by closing the accelerator inlet valve and loosening the drain plug 11. This allows pressure in the inlet chamber to drop, causing the accelerator to trip in the same manner as it does when the system pressure is lowered by the opening of sprinklers.

MAINTENANCE OF RESTRICTION DEVICE

The major cause of trouble or operation failure with accelerators is the presence of foreign matter that has come from the piping system. Dirt, corrosion deposits, chips, and pipe joint compound can clog the screen and filter felts. If this happens, close the accelerator inlet valve and remove drain plug 11 to release any pressure. Then unbolt and remove pressure chamber 1, unscrew restriction device protection cap 9 and restriction device 10, and remove all three restriction device felts 3. Carefully clean restriction device screen 8 and restriction device 10 by washing in an appropriate safety solvent.

When reassembling, be sure the restriction device 10 tightened to the diaphragm plate and stem 7. Use new restriction device felts 3 as these cannot be salvaged. It is important that there be no leaks around the drain plug 11 between the two chambers, gage openings, and gasket. After cleaning, the accelerator should be tripped to insure that it is working properly.

3.15 Grinnell Models A1, A2, A3, A4, A5, A6 Accelerators

Grinnell Dry-Pipe Accelerator

Model A1 - 1919 to 1922

Model A2 - 1922 to 1931

Model A3 - 1931 to 1932

Model A4 - 1932 to 1937

Model A5 - 1937 to 1960

Model A6 - 1960 to Date

Grinnell Corp., Providence, R.I.

The Grinnell accelerator, Models A1, A2, A3, A4, A5 and A6 are designed for use with the Grinnell No. 12 and Models C, D, E and E-2 dry-pipe valves, but may be used with Models A and B by the use of an auxiliary adapter and with other makes of dry valves by means of a special attachment.

DESCRIPTION

Refer to Figures 131 and 132.

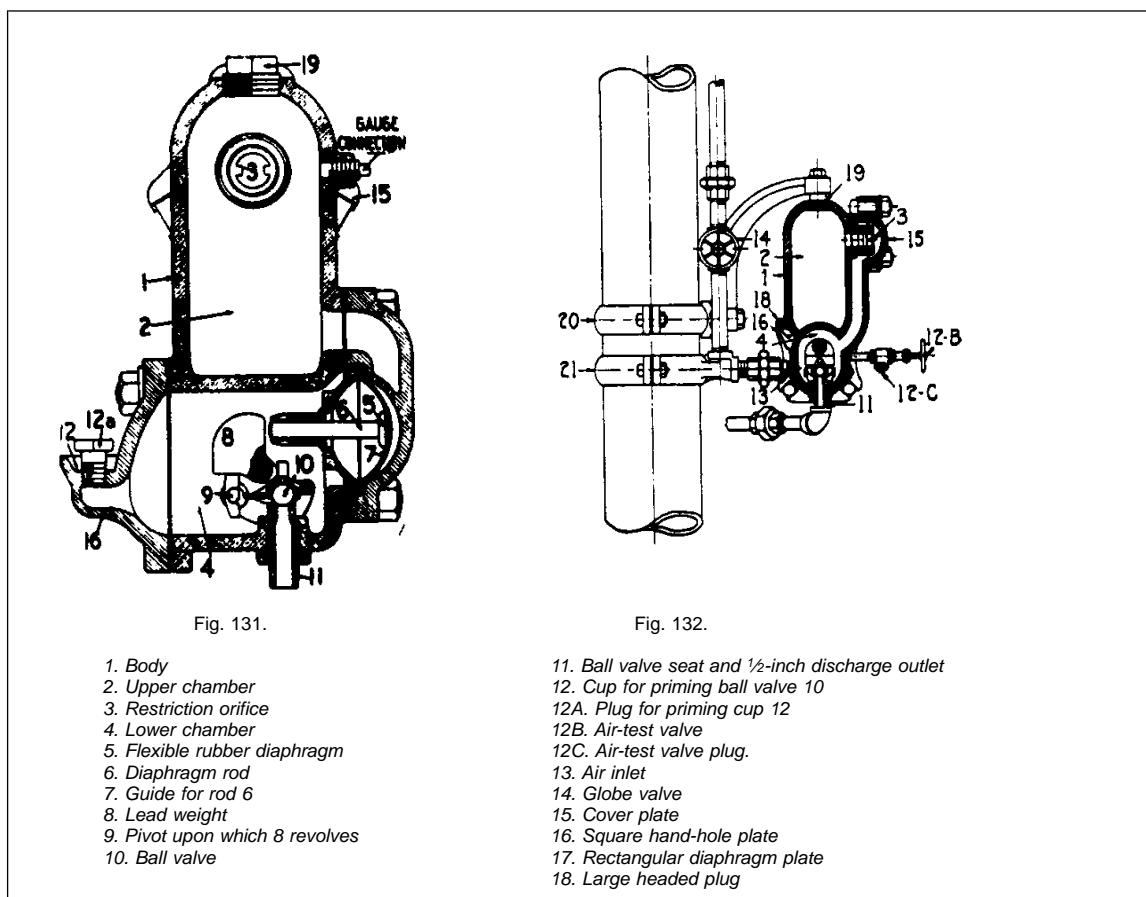

Fig. 131.

Fig. 132.

1. Body
2. Upper chamber
3. Restriction orifice
4. Lower chamber
5. Flexible rubber diaphragm
6. Diaphragm rod
7. Guide for rod 6
8. Lead weight
9. Pivot upon which 8 revolves
10. Ball valve

11. Ball valve seat and 1/2-inch discharge outlet
12. Cup for priming ball valve 10
- 12A. Plug for priming cup 12
- 12B. Air-test valve
- 12C. Air-test valve plug.
13. Air inlet
14. Globe valve
15. Cover plate
16. Square hand-hole plate
17. Rectangular diaphragm plate
18. Large headed plug

Fig. 131. Cross section of accelerator.

Fig. 132. Cross section of accelerator showing connection to air side of dry-pipe valve.

Lower chamber 4 is connected to the air side of the dry-pipe valve through globe valve 14 by means of a 3/4-inch pipe. Upper chamber 2 is connected to 4 by a passage containing an orifice between two screens of Monel metal cloth 3. A flexible rubber diaphragm 5 is also located between chambers 2 and 4. Under normal conditions, pressures in these chambers and in the sprinkler system are the same, equalizing by means of the pipe connection and the orifice. In case the pressure in 4 is reduced rapidly due to a sprinkler opening, there will be an excess in chamber 2 caused by the restrictive effect of the orifice. This will force diaphragm

5 against rod 6, overbalancing lead weight 8. This in rotating opens ball valve 10, allowing air in chamber 4 to pass through 11 and into intermediate chamber of dry-pipe valve. The flow of air closes automatic drip valve 27 (Fig. 133), and the pressure builds up under the air clapper, destroying the differential and causing the dry-pipe valve to trip.

For dry systems of large capacity, an auxiliary chamber is piped to chamber 2 to increase the pressure chamber capacity.

INSPECTING ACCELERATOR

1. See if valve 14 (Fig. 133) is wide open.

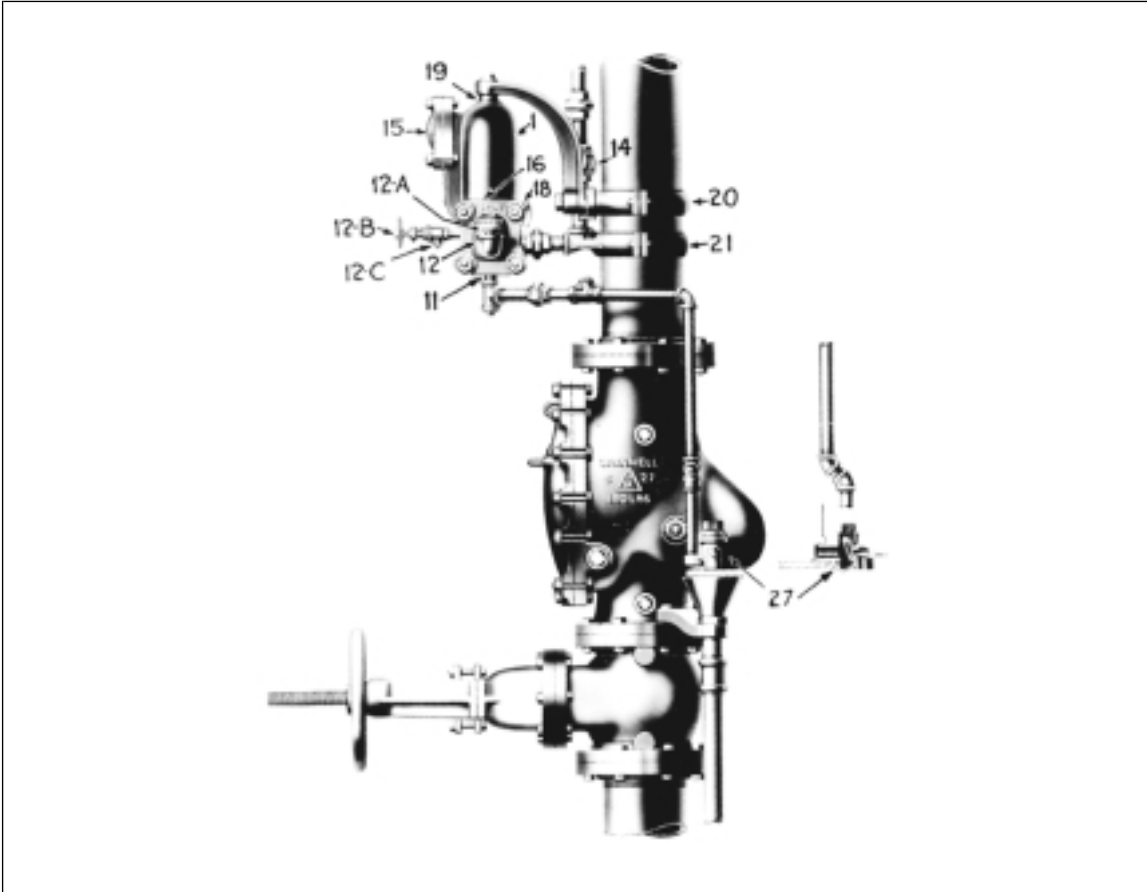

Fig. 133. Accelerator installed to Models C and D dry-pipe valves.

2. Note if pressure in chamber 2 (Fig. 131) as indicated by the gage on the left side of the accelerator is the same as that in the dry system.

If pressures are different, that in the system should be increased a few pounds and a reading taken in about three minutes to determine if the pressure in upper chamber 2 has increased a similar amount. If it has not it indicates that the orifice 3 is obstructed. Close valve 14, open cover 15, remove orifice 3 and wash screens, also entire interior of accelerator. Replace orifice assembly and cover and open valve 14. If the orifice is still found to be obstructed, the orifice assembly should be returned to the manufacturer for repairs. In this case valve 14 is left closed, the accelerator will be out of service, but the dry-pipe valve will remain operative.

3. See that the priming water in the dry-pipe valve is not above its proper level. Remove plug 12 C, open valve 12 B *slightly* and if water appears draw it off, then close 12 B and replace plug. This is important in order to prevent an accumulation of water which might rise high enough to reach orifice 3, making the accelerator inoperative or causing it to trip prematurely.

4. Make sure by pushing on plunger 28 (Fig. 134) that the clapper of drip valve 27 (Fig. 133) is off its seat and free to move. If clapper is closed when system is under air pressure, water which might leak by the seats of the dry-pipe valve will remain in the intermediate chamber where it may eventually build up pressure and trip the dry-pipe valve.

TESTING ACCELERATOR

The accelerator may be tested or operated, if desired, without tripping the dry-pipe valve in the following manner:

1. Close the main gate valve below dry-pipe valve and open the 2-inch test drain to relieve pressure on the water seat of the dry-pipe valve.
2. Close valve 14 (Fig. 132).

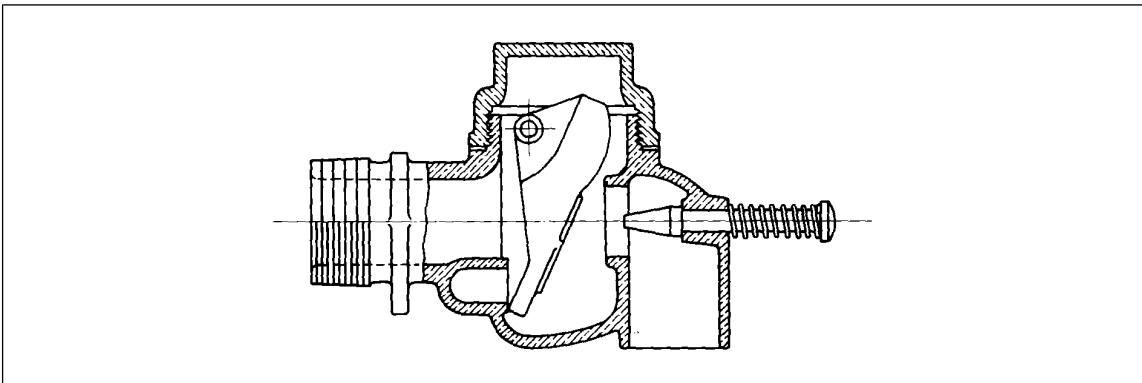

Fig. 134. Automatic drip valve.

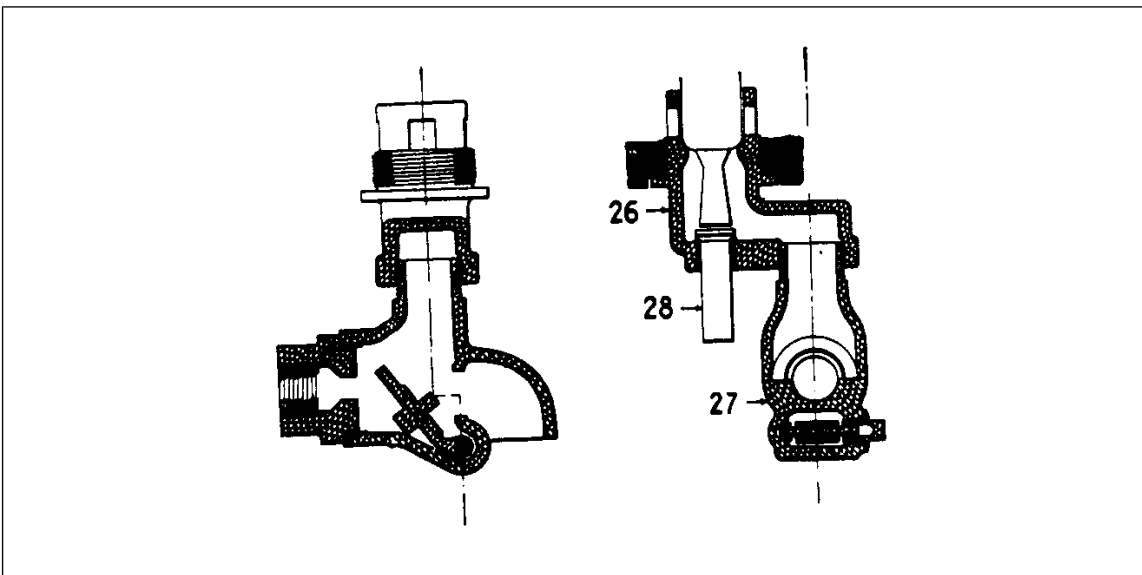

Fig. 135. Special drip valve used when accelerator is attached to Models C and D dry-pipe valves.

3. Remove plug 12 C and open air-test valve 12 B. This will drop the air pressure in the lower chamber 4 rapidly and trip the accelerator. The remaining pressure will pass through the discharge outlet 11, closing drip valve 27, and pass into the intermediate chamber of the dry-pipe valve.
4. After this test the accelerator should be set as directed in the next section.
5. Observe if gage on accelerator is slowly rising. It will take three minutes for the pressure in upper chamber 2 to become the same as that in the dry system.

6. Make sure that the main gate valve, drip valve 27, and valve 14 are left open.

SETTING ACCELERATOR

1. Close valve 14 on the pipe from the sprinkler system to accelerator and set the dry-pipe valve in the usual way.
2. Remove hand-hole plate 16, open valve 14 slightly to drain the $\frac{3}{4}$ -inch pipe connection, then close 14.
3. Remove plug 18 to drain chamber 2, and replace plug 18, after draining.
4. Carefully clean ball valve 10 (Fig. 131) and seat 11, lift weight 8 into position (slightly beyond the vertical), and replace hand-hole plate 16.

Caution: Never apply grease, tallow, or any other substance to ball valve 10 or seat 11. The accelerator should never be set without cleaning valve 10 and seat 11, as sediment or foreign material at these points will cause leakage when subjected to air pressure.

5. Remove priming plug 12 A and air-test plug 12 C. Open air-test valve 12 B and slowly pour water into the priming cup 12 (Fig. 131), until it runs out at valve 12 B, then close valve 12 B and replace plugs 12 A and 12 C.

6. Open valve 14. See that ball valve 10 is tight by noting if there is any leakage of water or air at the drip-valve 27. If leakage is noted close valve 14. Clean valve 10 and its seat 11. Reset and prime.

3.16 Reliable Automatic Model A Accelerator

Reliable Automatic Model A Accelerator 1939 TO 1974

Reliable Automatic Sprinkler Co., Mount Vernon, N. Y.

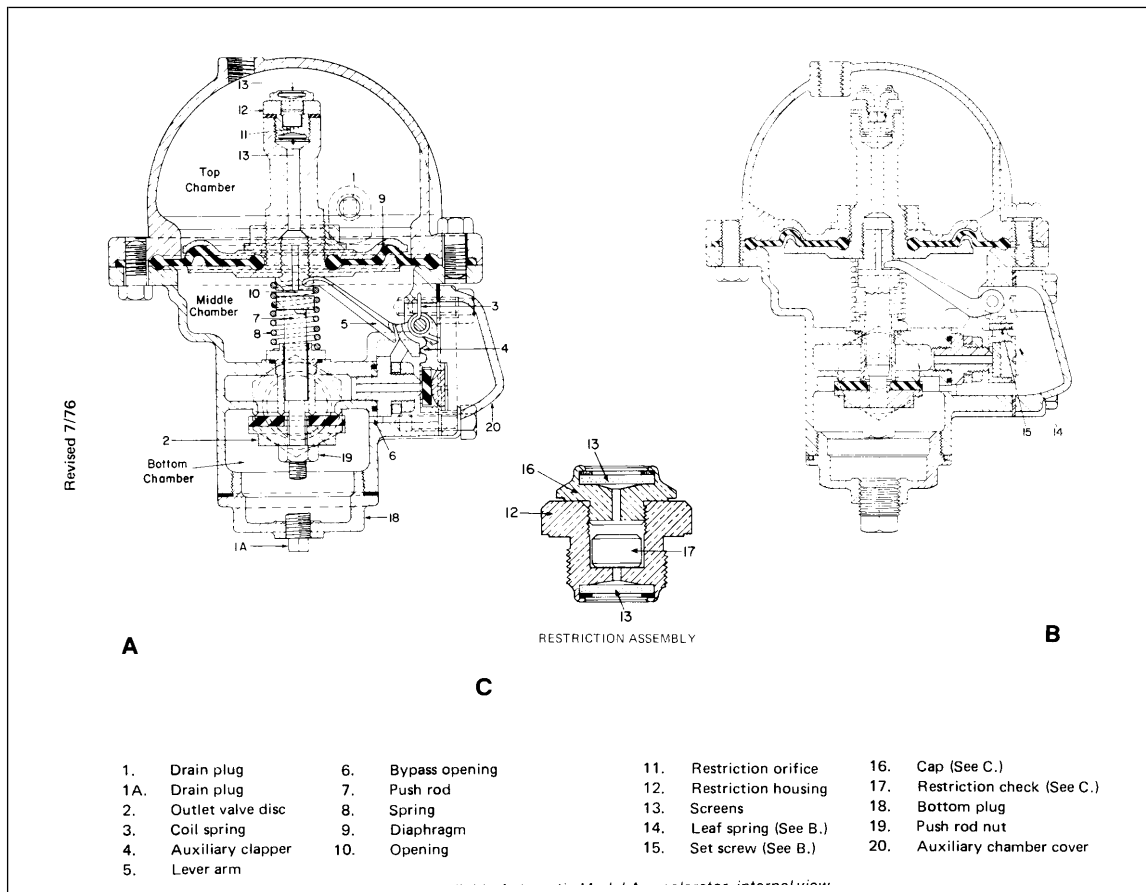

Fig. 136. Reliable Automatic Model A accelerator, internal view.

DESCRIPTION

Reliable Model A accelerator can be used with practically all types of dry valves. There are two versions of the Model A accelerator. They differ in that one (Fig. 136-B) has set screw 15 which is factory set and leaf spring 14 which replaces coil spring 3 (Fig. 136-A). The accelerator in Fig. 136-A was produced from 1939 to 1969 while that in Fig. 136-B was produced from 1969 to 1974.

Essentially this accelerator has three chambers. Air pressure from the sprinkler system enters the bottom and middle chambers. Air pressure will also enter the top chamber through opening 10 and restriction assembly 11, 12 and 13. In set condition, pressure in these three chambers is equal. Push rod 7 runs almost the length of the accelerator housing. Mounted on it are outlet valve disc 2, diaphragm 9, spring 8, and restriction orifice assembly 11, 12, and 13. To prevent restriction orifice 11 from getting clogged, screens 13 are mounted on the inlet and outlet side of restriction housing 12.

When system pressure drops rapidly, pressure in the bottom and middle chambers also drops. Pressure in the top chamber will not drop as quickly due to restriction orifice 11. This excess pressure forces diaphragm 9 downward.

Lever arm 5 then opens auxiliary clapper 4 and exhausts the middle chamber pressure under diaphragm 9. Pressure in the top chamber increases, diaphragm 9 moves down quickly, and push rod 7 releases outlet valve disc 2 from its seat. Air from the sprinkler system then flows through the accelerator to the intermediate chamber of the dry valve, destroying its differential and causing it to trip.

INSPECTION

1. Check that air supply valve C is wide open.
2. Check that pressure gauge D indicates the same pressure as that in the sprinkler system. If the pressures differ, increase sprinkler pressure a few pounds and note if pressure on gauge D increases a similar amount. (This will take about 10 minutes.) If the pressures do not equalize, restriction orifice 11 or screens 13 are plugged.

Clean the restriction orifice as outlined in this data sheet. If the restriction assembly is still obstructed after cleaning, send it to the manufacturer for repair. Although the accelerator will be out of service, the dry-pipe valve will operate.

3. Check drip cup of dry valve for air leak from the accelerator. If no air leak is present, auxiliary clapper 4 and outlet valve disc 2 are properly seated. If air is heard, these two clappers must be cleaned as outlined in this data sheet.

TESTING

(Without operating dry valve)

1. Close air supply valve C.
2. Close main control valve A.
3. Open main drain valve B.
4. Loosen drain plug 1A. Accelerator will now operate.
5. Tighten securely drain plug 1A.
6. Follow steps 3 to 8 under **SETTING**.

SETTING

1. Close air supply valve C and set the dry-pipe valve, using the appropriate data sheet or manufacturer's instructions. Do not open main control valve A until later.
2. Remove drain plugs 1 and 1A. Allow water to drain. Replace securely when finished.
3. Slightly open air supply valve C to permit system air pressure to pass to the accelerator. (Excessive opening of this valve could cause dry valve to trip.)
4. Check that air pressure in the accelerator quickly equalizes with sprinkler air pressure.

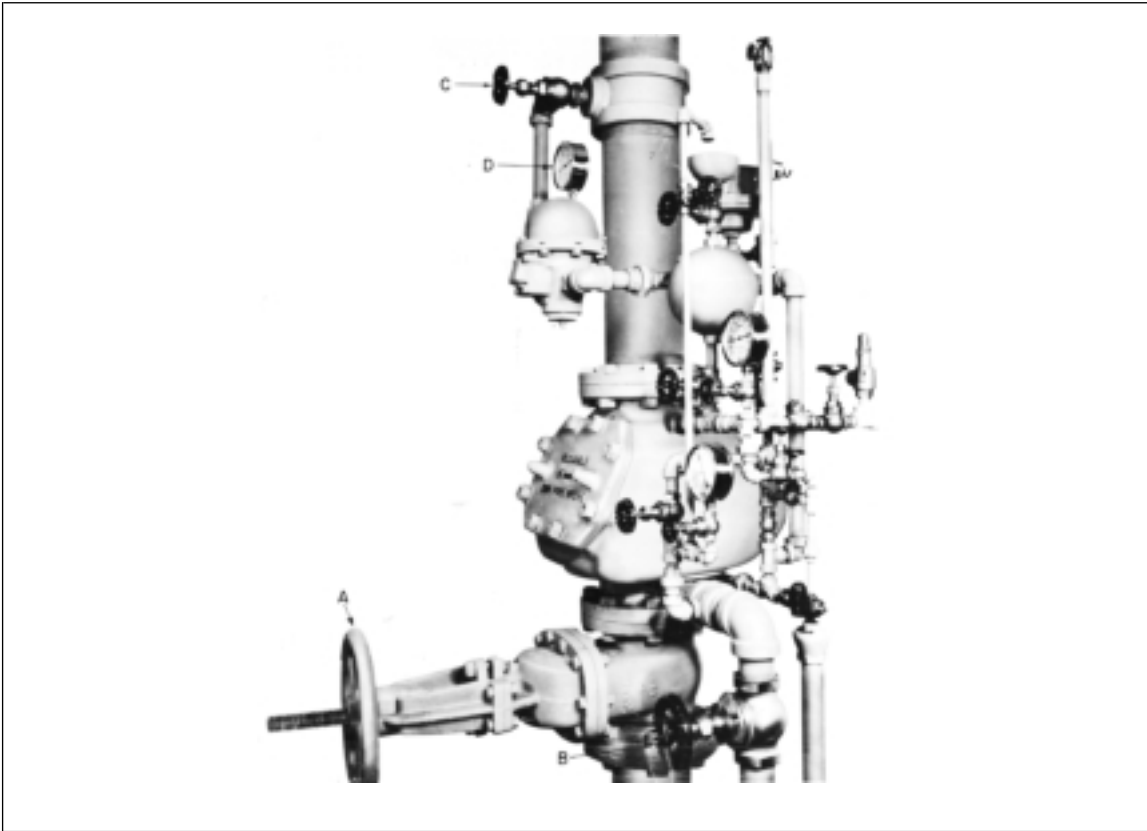

Fig. 137. Reliable Automatic Model A accelerator trim.

5. Observe drip cup of dry-pipe valve. If no air leak occurs, auxiliary clapper 4 and outlet valve clapper 2 are properly seated.
6. Open wide air supply valve C.
7. **Open wide main control valve A.**
8. Test water supply by opening main drain valve B.

CLEANING RESTRICTION

1. Close air supply valve C and remove top chamber cover.
2. Remove restriction housing 12 by applying wrench to housing 12.
3. Unfasten cap 16 from restriction housing 12. Remove restriction check 17 by turning restriction housing 12 upside-down.
4. Wash restriction orifice 11, cap 16, and restriction housing 12 in clear water or oil-free solvent.
5. Reassemble restriction assembly, replace restriction in accelerator, and tighten securely.
6. Replace top chamber cover, being sure the cover is uniformly tightened.
7. Open air supply valve A.

CLEANING OUTLET VALVE DISC

1. Close air supply valve C and remove bottom plug 18.
2. Remove push rod nut 19 and slide outlet valve disc 2 off push rod 7.
3. Clean outlet valve disc 2. If the rubber facing appears scorched, replace it with a new one.
4. Reassemble these parts in the accelerator. Be sure bottom plug 18 is tightened securely.

5. Open air supply valve C.

CLEANING AUXILIARY CLAPPER

1. Close air supply valve C.
2. Remove auxiliary chamber cover 20.
3. Lift auxiliary clapper 4 and carefully clean the clapper and its seat. Replace the facing if it shows excessive wear.
4. Place auxiliary clapper 4 on its seat and replace auxiliary chamber cover 20. Be sure the cover is uniformly tightened.
5. Open air supply valve C.

3.17 Reliable Model B Accelerator

Reliable Model B Accelerator With Built-in Antiflooding Device 1972 To Date

Reliable Automatic Sprinkler Co., Inc., Mt. Vernon, N.Y.

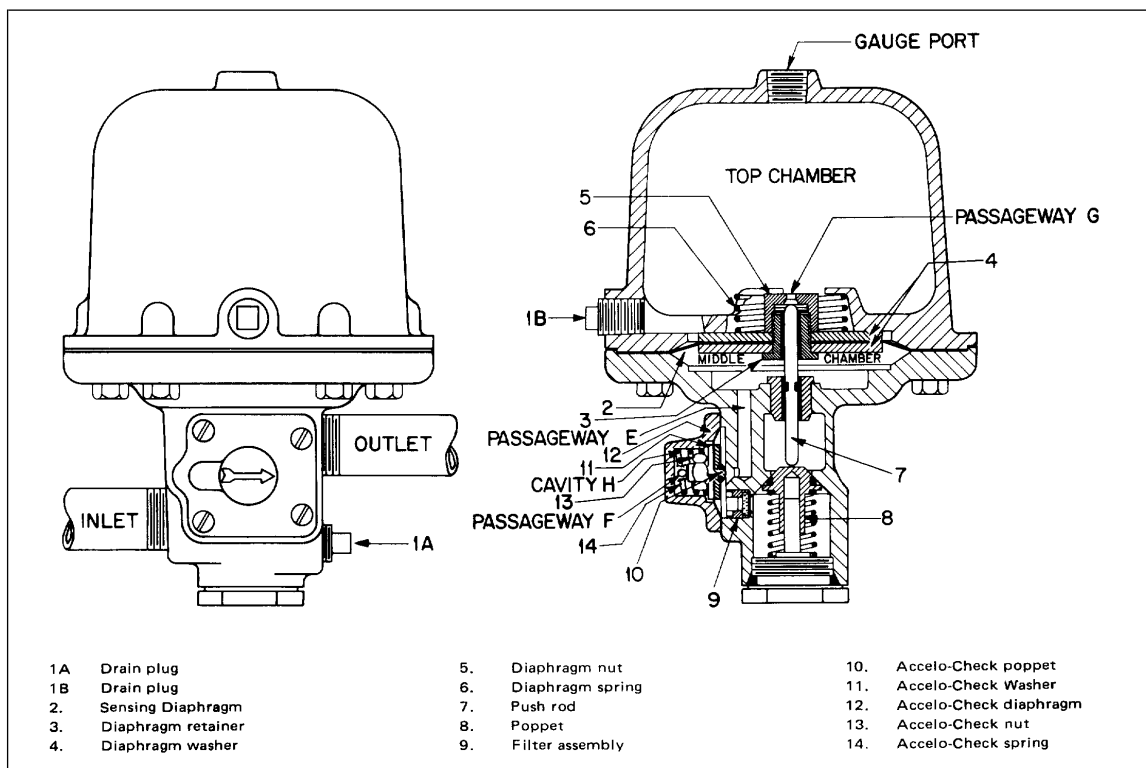

Fig. 138. Reliable Model B Accelerator.

DESCRIPTION

The Reliable Model B accelerator (Fig. 138) consists of a top chamber and a middle chamber divided by a diaphragm assembly 2, 3, 4, 5 and 6. Attached to the accelerator is an Accelo-check diaphragm assembly 10, 11, 12, 13 and 14 which will prevent water and any foreign debris from entering the accelerator when the dry valve is tripped.

OPERATION

When the control valve to the accelerator is opened, air enters the inlet pipe and passes through the filter assembly 9. This pressure buildup opens the Accelo-check diaphragm assembly 10, 11, 12, 13 and 14

allowing air to travel through passageway E to the middle chamber. This air lifts the diaphragm assembly 2, 3, 4, 5 and 6 filling the top chamber through passageway G. Air quickly fills the top chamber and the diaphragm assembly 2, 3, 4, 5 and 6 moves down to rest on the push rod 7 thus closing passageway G except for minor leakage which compensates for system air pressure fluctuations.

When system air pressure drops, the top chamber is left with a greater pressure than the middle chamber. This pressure acts through push rod 7 to open poppet 8 allowing air from the inlet to flow through to the outlet side and on to the intermediate chamber of the dry valve. The pressure buildup in the outlet passage also forces air up through passageway F to cavity H forcing the Accelo-check diaphragm assembly 10, 11, 12, 13 and 14 closed. This shuts passageway E preventing any water or contaminating material from entering the restriction area.

RESETTING OF ACCELERATOR

1. Close valve controlling air supply to the accelerator.
2. Close valve controlling water supply to the dry valve.
3. Reset dry valve (procedure outlined in appropriate data sheet) but **do not reopen valve controlling water supply** at this time.
4. Remove the drain plugs 1A and 1B to vent air and water from the accelerator. Replace plugs securely (air tight).
5. Slightly open valve controlling air supply, permitting system air pressure to pass to the accelerator. The air pressure gauge on the top chamber will increase to match system air pressure.
6. Depress ball drip valve. If no air leak is noted, accelerator is properly reset.
7. Fully open valve controlling air supply.
8. **Open valve controlling water supply to dry-pipe valve.**

TESTING ACCELERATOR (Without Tripping Dry Valve)

1. Close valve controlling air supply to accelerator.
2. Loosen the drain plug 1A on the accelerator to lower the pressure at the inlet. The accelerator should operate.
3. Reset the accelerator by following the previous steps given under **RESETTING** starting at step 5.

INSPECTION OF ACCELERATOR

1. Make sure valve controlling air supply is fully open.
2. Observe air pressure gauges of accelerator and dry-pipe valve. Pressures should be equal.
3. Depress ball drip valve and observe if any leakage occurs. If no air or water leaks are visible, the accelerator is properly set. If an air or water leak is observed, setting of both the dry valve and accelerator should be checked.

3.18 Rockwood Model C Exhauster

Rockwood Model C Exhauster 1931 TO DATE

Firematic Sprinkler Device Inc., Worcester, Massachusetts (Formerly Bliss-Rockwood Sprinkler Company)

DESCRIPTION

The Rockwood Model C exhauster can be used with practically all types of dry valves. In set condition, pressure from the sprinkler system enters lower chamber 16 and auxiliary chamber 2 via passageway 15. Air pressure then enters upper chamber 1 through restriction orifice 4. Pressure is now equalized in the exhauster and auxiliary valve 8 remains closed.

When a sudden drop in pressure occurs in the sprinkler system, pressure in auxiliary chamber 2 is decreased. Upper chamber 1 cannot relieve its pressure as rapidly as chamber 2 due to restriction orifice 4. The excess pressure forces auxiliary diaphragm 6 and lever 7 downward, opening auxiliary valve 8 and allowing pressure

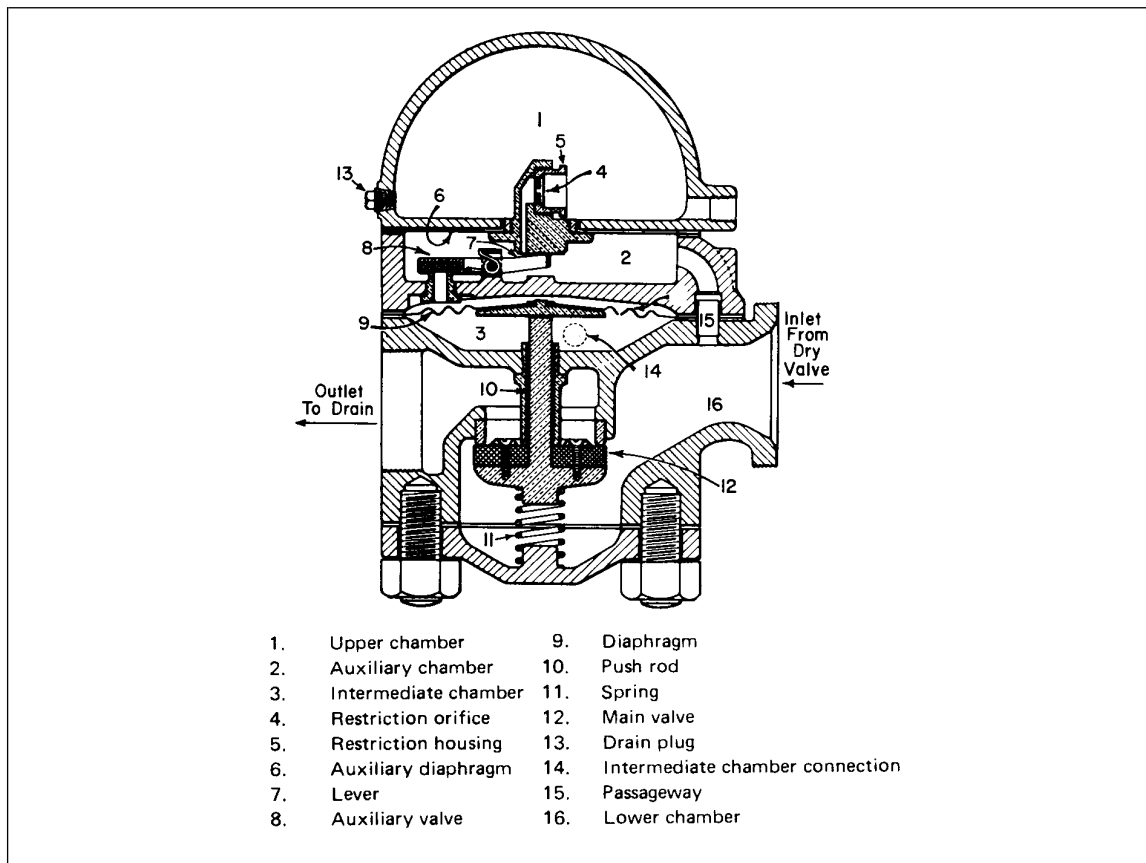

Fig. 139. Rockwood exhauster Model C, internal view.

to enter intermediate chamber 3 of the exhauster. This pressure forces main diaphragm 9 down, causing push rod 10 to open main valve 12. Air is now exhausted from the sprinkler system through the 2-in. outlet drain.

After the dry-pipe valve trips, water from the intermediate chamber of the dry-pipe valve enters intermediate chamber 3 of the exhauster. The water pressure, aided by spring 11 in the exhauster, closes main valve 12 and prevents waste of water through the exhauster.

While water remains in the sprinkler system, the exhauster contains water, and restricted orifice 4 slowly admits water to upper chamber 1. When the sprinkler system is drained and before setting the exhauster, water must be drained out of the inlet pipe and auxiliary chamber 2. Upper chamber 1 is drained by removing drain plug 13.

INSPECTION

1. Check that air supply valve C is open.
2. Check that pressure gauge D indicates the same pressure as that in the sprinkler system. If the pressures differ, increase sprinkler pressure a few pounds and note if the pressure on gauge D increases a similar amount. (This will take about 5 minutes.) If the pressure does not increase, restriction orifice 4 is probably plugged. Close air supply valve C. Remove restriction orifice 4 and carefully wash the orifice and metal screens. Replace the orifice assembly making the joint tight. If the restriction orifice is still obstructed, send it to the manufacturer for repairs. Make sure that air supply valve C is closed tightly. Although the exhauster will be out of service, the dry-pipe valve will still operate.
3. Check priming level of the dry valve. Priming water should not be allowed to reach the level of air supply valve C.
4. Make sure after inspecting the exhauster that air supply valve C is wide open.

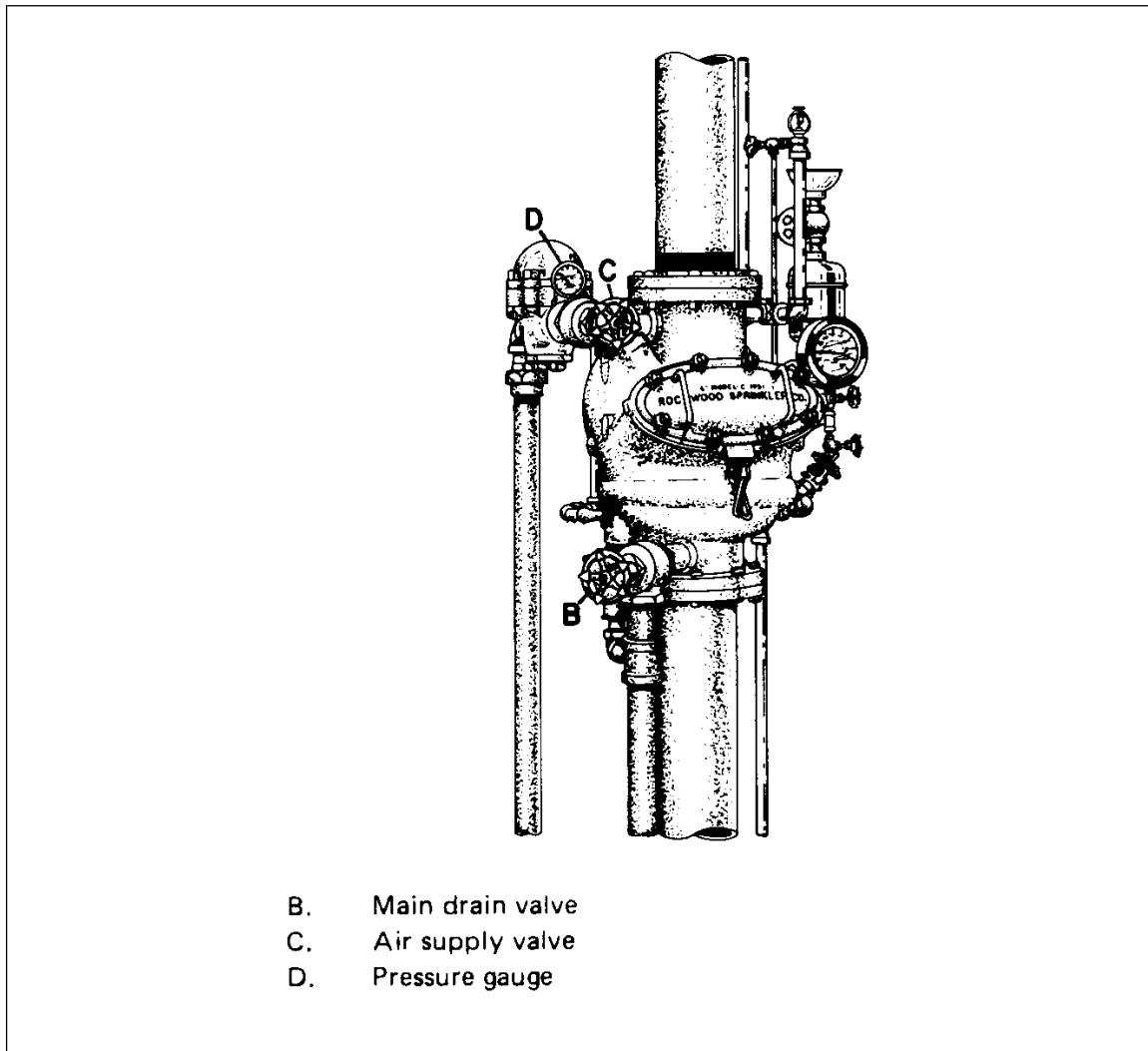

Fig. 140. Rockwood exhauster Model C trim.

TESTING

(Without operating dry pipe valve)

1. Close air supply valve C.
2. Close the main control valve supplying water to the system.
3. Open main drain valve B.
4. Loosen the bolts holding the bottom plate of the exhauster, lowering the pressure in the inlet chamber and causing the exhauster to trip. Then tighten the bolts making sure that the joint will not leak air from the system.
5. Close main drain valve B.
6. Follow steps 3 to 6 under **SETTING**.

SETTING

1. Close air supply valve C and set the dry-pipe valve using the appropriate data sheet or manufacturer's instructions. Do not open the main control valve until later.

2. Remove drain plug 13 in upper chamber 1 of the exhauster and drain any water which may have accumulated. Replace when finished, tightening the joint because any leakage would retard the action of the exhauster.
3. Open air supply valve C and check that main valve 12 is properly seated by noticing if any air escapes through the outlet of the exhauster.
4. Observe if the pressure reading on gauge D is slowly rising. It will require from 3 to 5 minutes for pressure in the upper chamber to equal that in the dry system.
5. **Open wide the main control valve.**
6. Test the water supply by opening main drain valve B.

3.19 Rockwood Model A Exhauster

Rockwood Exhauster MODEL A, 1924 TO 1931

Firematic Sprinkler Devices Inc.^{*}, Worcester, Mass.

DESCRIPTION

Rockwood Model A exhauster (Fig. 141) is designed for use with the Rockwood Models A, B, and C dry-pipe valves, but can be used with practically all other types of dry valves. Air pressure from the sprinkler system enters upper chamber 1 and passes to lower chamber 2 via restriction orifice 3. Air pressure equalizes in the two chambers, and springs 6 and 8 hold their respective valves closed. When system air pressure is reduced, air pressure in upper chamber 1 is also reduced. Lower chamber 2 cannot relieve its pressure due to restriction orifice 3 which forces diaphragm 10 upward. Lever 11 lifts, opening main valve 7 and allowing air to flow from the sprinkler system to drain.

After the dry valve trips, water from the intermediate chamber raises auxiliary diaphragm 12 opening auxiliary valve 9. The excess pressure in lower chamber 2 is relieved through the drain pipe. Water entering upper chamber 1 forces diaphragm 10 down closing main valve 6 preventing any waste of water through the drain. Any water which enters lower chamber 2 will drain out through auxiliary valve 9.

^{*}Formerly Rockwood Sprinkler Co.

INSPECTION

1. Check that air supply valve B (Fig. 142) is wide open.
2. Check that pressure gauge C indicates the same pressure as that in the sprinkler system. If the pressures differ, increase sprinkler pressure a few pounds and note if the pressure on gauge C increases a similar amount. (This will take about 10 minutes.) If the pressure does not increase, restriction orifice 3 or screens 4 are plugged. Close air supply valve B and remove cover D and restriction housing 5. Carefully clean screens 4 and restriction orifice 3. Replace restriction orifice 3, screens 4, restriction housing 5, and cover D. Open air supply valve B. If the orifice is still obstructed, close air supply valve B, and send the disc containing restriction orifice 3 and screens 4 to the manufacturer for repair. The exhauster will be out of service, but the dry valve will operate.
3. Check level of priming water in dry valve. Water should never be allowed to reach the level of air supply valve B.

TESTING (Without Operating Dry Valve)

1. Close air supply valve B.
2. Close the main control valve.
3. Open main drain valve A.
4. Open plug 13 slightly, causing the exhauster to operate. Tighten plug 13 when finished.
5. Close main drain valve A.
6. Follow steps 4 to 7 under **SETTING** to reset the exhauster.

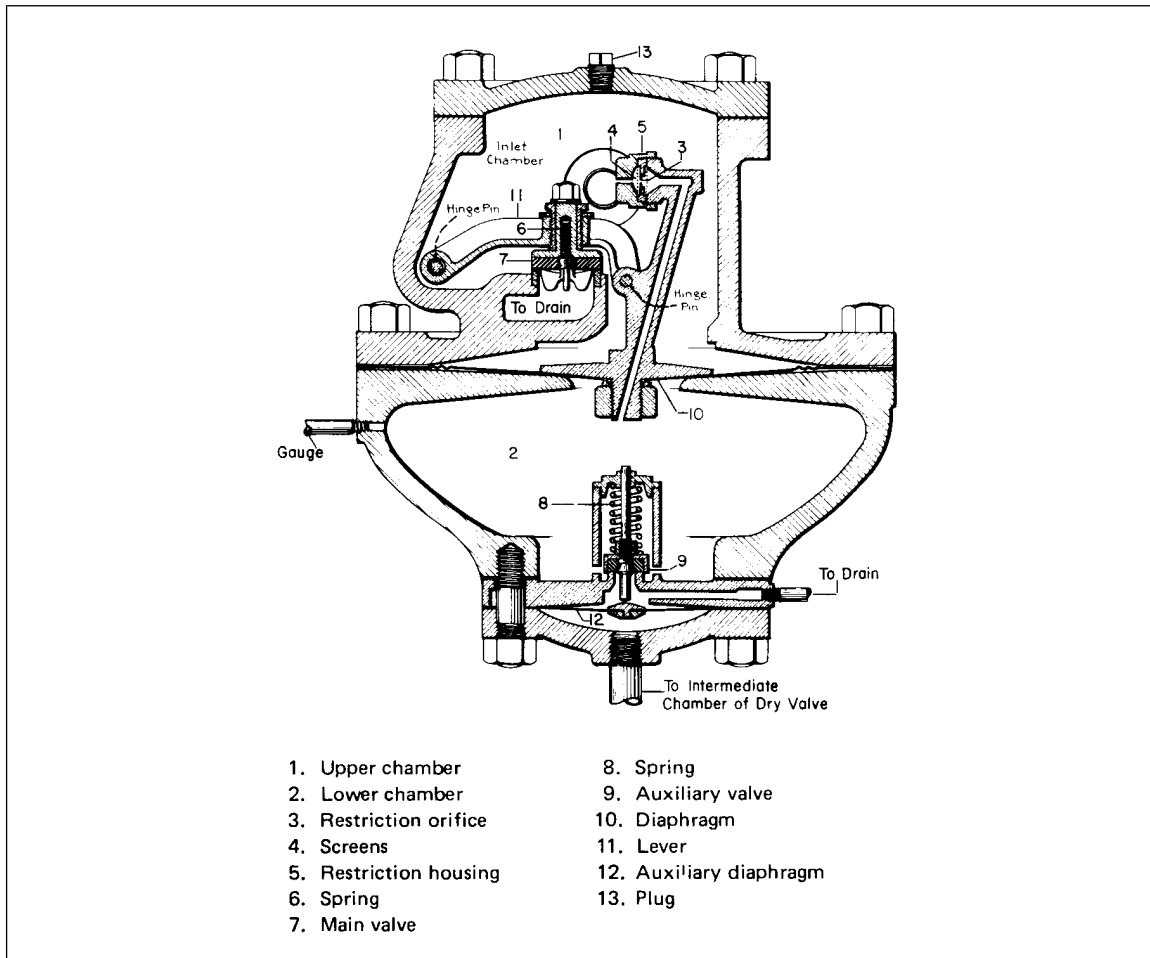

Fig. 141. Rockwood exhauster Model A, internal view.

SETTING

1. Close air supply valve B and set the dry-pipe valve using the appropriate data sheet or manufacturer's instructions. Do not open the main control valve until later.
2. Remove cover D and orifice housing 5. Carefully clean screens 4 and restriction orifice 3.
3. Replace screens 4, restriction housing 5, and cover D. It is essential to replace the restriction housing 5 tight on its seat, as any air leakage would retard exhauster operation.
4. Open air supply valve B and note that main valve 7 is seated properly by listening at the drain outlet. If air is escaping, remove cover D and thoroughly clean main valve 7. Repeat this step.
5. Check pressure gauge C. It will take about 12 minutes to show the same pressure as that in the sprinkler system.
6. **Open wide main control valve.**
7. Test the water supply by opening main drain valve A.



Fig. 142. Rockwood exhauster Model A trim.

3.20 Standard Model A Accelerator

Standard Model A Accelerator 1964

Standard Fire Protection Equipment Co., Charlotte, N. C.

DESCRIPTION

The Model A accelerator consists of a body divided into two chambers, a bottom or inlet chamber, which is connected by piping with the system riser above the dry pipe valve, and a pressure storage chamber at the top, which communicates through a restricted passageway with the inlet chamber. A diaphragm-operated valve mechanism controls the discharge port leading from the inlet chamber in the body, the port being pipe-connected with the intermediate chamber of the dry pipe valve.

OPERATION

System air pressure passes freely into the inlet chamber of the accelerator through the connecting piping, then slowly through a restricted passage into the pressure storage chamber, eventually establishing full system pressure in the pressure-storage chamber.

Operation of a sprinkler produces a drop of pressure in the system piping and this is accompanied by a similar drop in pressure in the inlet chamber of the accelerator. The pressure in the pressure-storage chamber, however, cannot quickly drop on account of the restriction in the communicating passage between the two chambers of the accelerator. A difference in pressure between the inlet and pressure-storage chamber is thus established. The high pressure remaining in the pressure-storage chamber acts on the rubber diaphragm

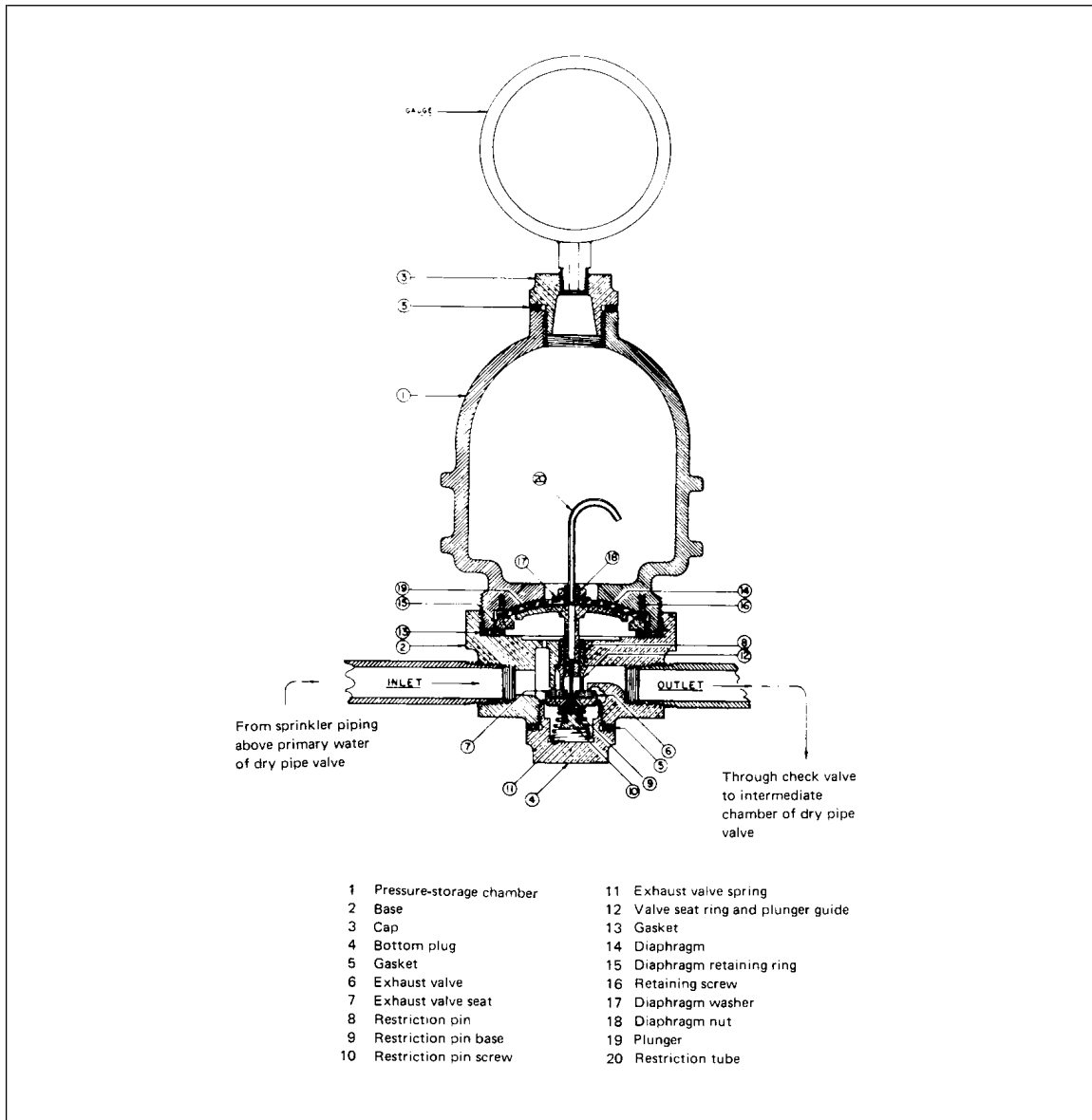

Fig. 143. Standard Model A Accelerator

forming a partition between the two chambers and moves diaphragm and bronze plates (against which the diaphragm contacts) and the discharge-port valve assembly (assembled with the plates) in a downward direction, thus opening the exhaust valve (6).

System air pressure then passes into the piping connecting with the intermediate chamber of the dry-pipe valve, fills the chamber, and thus equalizes the pressure on both sides of the air clapper of the dry-pipe valve. This results in tripping of the valve.

RESETTING

Following operation, the accelerator will normally reset itself after a short period of time. However, it is advisable to remove the bottom plug (4) thereby releasing any condensation that may have accumulated. After making certain that exhaust valve seat (7), restricting orifice pin (8), and valve seat ring (12) are thoroughly clean, replace the plug and the accelerator will automatically reset.

3.21 Star Models A, AA, B, BB Exhausters

Star Exhauster

MODEL A - 1930 - 1936

MODEL AA - 1936 - 1949

MODEL B - 1949 - 1956

MODEL BB - 1956 TO DATE

Star Sprinkler Corp., Philadelphia, PA.

DESCRIPTION

The Star exhauster is separated into an upper and a lower chamber by a rubber diaphragm held between flanges on the upper and lower valve stems. A longitudinal hole in the upper and lower valve stems connects with a transversely drilled hole near the bottom of the lower stem permitting airflow between the upper and lower chambers. A ball in a cradle (Models A and AA), a check valve with a small orifice (Model B) mounted on top of the upper valve stem, or a fixed restriction orifice (Model BB) in the side of the upper valve stem controls the rate of air flow between the two chambers. The upper chamber contains a separate auxiliary valve which is opened by a downward movement of a lug on the upper valve stem. At the bottom of the lower chamber is located the two-inch main valve assembly which is attached to a short valve stem mounted coaxially on the lower valve stem.

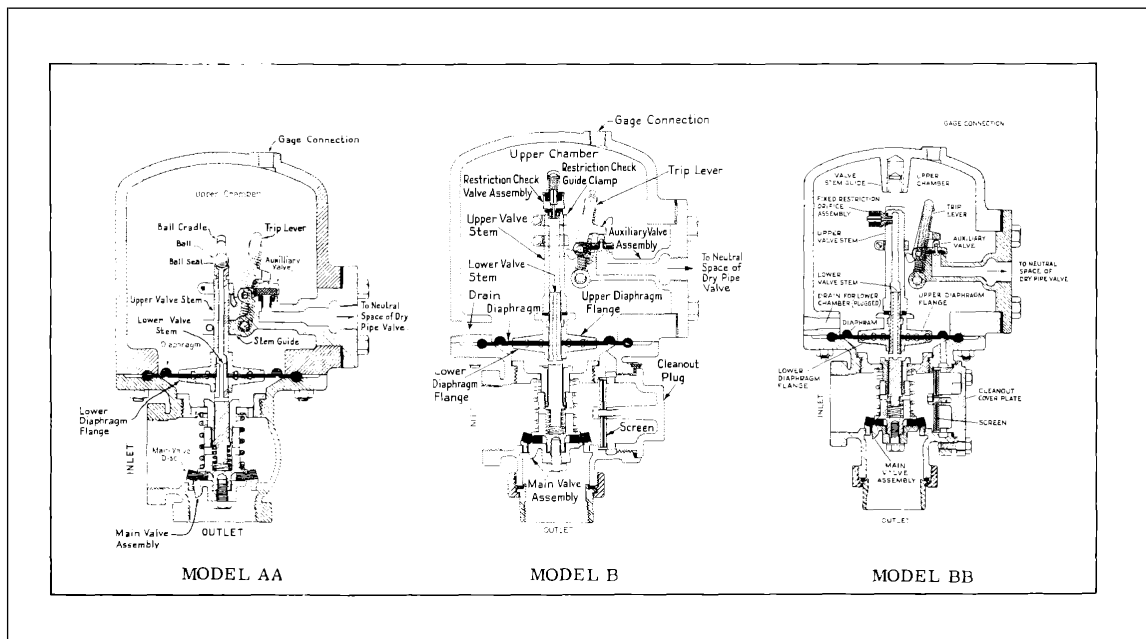

Fig. 144. Star Models A, AA, B, BB Exhausters

The inlet of the exhauster (lower chamber) is connected to the dry-pipe system through a 2-inch angle valve (A) (see page 2) and 2-inch pipe (B), which also serve as a support for the exhauster. A 3/4-inch pipe (C) connects the outlet of the auxiliary valve in the upper chamber of the exhauster to the neutral space of the dry-pipe valve. A plug (D) is furnished in the 2-inch elbow in the connection from the dry-pipe system. This plug can be removed for draining the 2-inch connection (B), leaving enough water to prime the exhauster.

Cast iron was substituted for brass in the body, and the shape of the top of the body of the exhauster was changed when Model A was superseded by Model AA. In the change to Model B and subsequently in Model BB, a lip was included in the upper diaphragm flange which would allow the use of a tool inserted through the cover plate hole to raise the main valve assembly for washing the main valve seat. The stem guide was also eliminated thus permitting the auxiliary valve assembly to be removed for inspection. In the current Model BB the upper valve stem has been lengthened so that its vertical movement can be guided within a bronze bushing in the top of the upper chamber casting. A cleanout plug, screwed into the body in Model B, and

bolted to the body in Model BB, was also provided to facilitate inspection of the main valve seat. This plug contains a stainless steel screen which protects the inlet to the ports in the lower valve stem from entry of obstructing material.

OPERATION

The pressure in the upper chamber equalizes with that of the dry-pipe system through the holes drilled in the upper and lower valve stems. The opening at the top of the upper valve stem is kept closed by a ball supported in a cradle (Models A and AA), a check valve with a small orifice (Model B), and a fixed restriction orifice in Model BB. Slow variations in pressure between the upper and lower chambers are equalized through these restrictions to the passage of air through the upper and lower valve stems. A rapid drop in pressure, such as when a sprinkler opens, results in a lowered pressure below the diaphragm. The diaphragm then moves downward enough for the lug on the upper valve stem to open the auxiliary valve and release the pressure in the upper chamber to the neutral space of the dry-pipe valve. A reversal of the differential in pressure now occurs because the upward airflow through the drilled-hole passage in the valve stem is restricted, and the diaphragm moves up lifting the main valve off its seat. The discharge to atmosphere through the 2-inch main valve rapidly reduces the air pressure in the dry-pipe system to the trip point of the dry-pipe valve.

After the dry-pipe valve trips, water from the neutral space of the dry-pipe valve enters the upper chamber through the auxiliary valve. The pressure of the water above the diaphragm, aided by the spring in the main valve assembly, closes the main valve and prevents waste of water.

MAINTENANCE

1. Make sure the valve A in the 2-inch connection from the dry system to the exhauster is wide open.
2. Note if the pressure as indicated by the gage F on the exhauster is the same as that in the dry-pipe system. If the pressures are not the same, increase that in the system a few pounds, and note if that indicated by the exhauster gage F increases a similar amount. If not, it indicates that the drilled-hole passage in the upper and lower stems is obstructed. The exhauster should then be removed so that this passage can be cleaned. If after cleaning the pressure still fails to equalize, the exhauster should be returned to the manufacturer for repairs. If this is done, make sure that the 2-inch valve A is closed tightly. In this case, the exhauster will be out of service, but the dry-pipe valve will remain operative.
3. Open the air-test petcock G on the dry-pipe valve slightly, and if any water appears, draw it off. Then tightly close petcock G.
4. Close valve A and remove the 1/4-inch plug D to drain the 2-inch connection and the lower chamber of the exhauster of any water which may have accumulated. Then tightly replace this plug. This is important to prevent an accumulation of water which might rise high enough to obstruct the restricted passage, making the exhauster inoperative or causing it to trip prematurely.
5. Open the 2-inch valve A wide.

TESTING

The exhauster may be tested or operated without tripping the dry-pipe valve as follows:

1. Close the 2-inch valve A.
2. Close the main gate valve below the dry-pipe valve.
3. Open 2-inch drain H of the dry-pipe valve to relieve the pressure on the water seat.
4. Unscrew the 1/4-inch plug D. This will release the air and lower the pressure in the lower chamber of the exhauster and cause the exhauster to trip.
5. Close the 2-inch drain valve H and tighten the 1/4-inch plug D.
6. Open the main gate valve and set the exhauster as described under Setting.

SETTING

1. Close main gate valve and set dry-pipe valve.
2. Drain the 2-inch connection B by shutting valve A and removing the 1/4-inch plug D; then replace the plug.

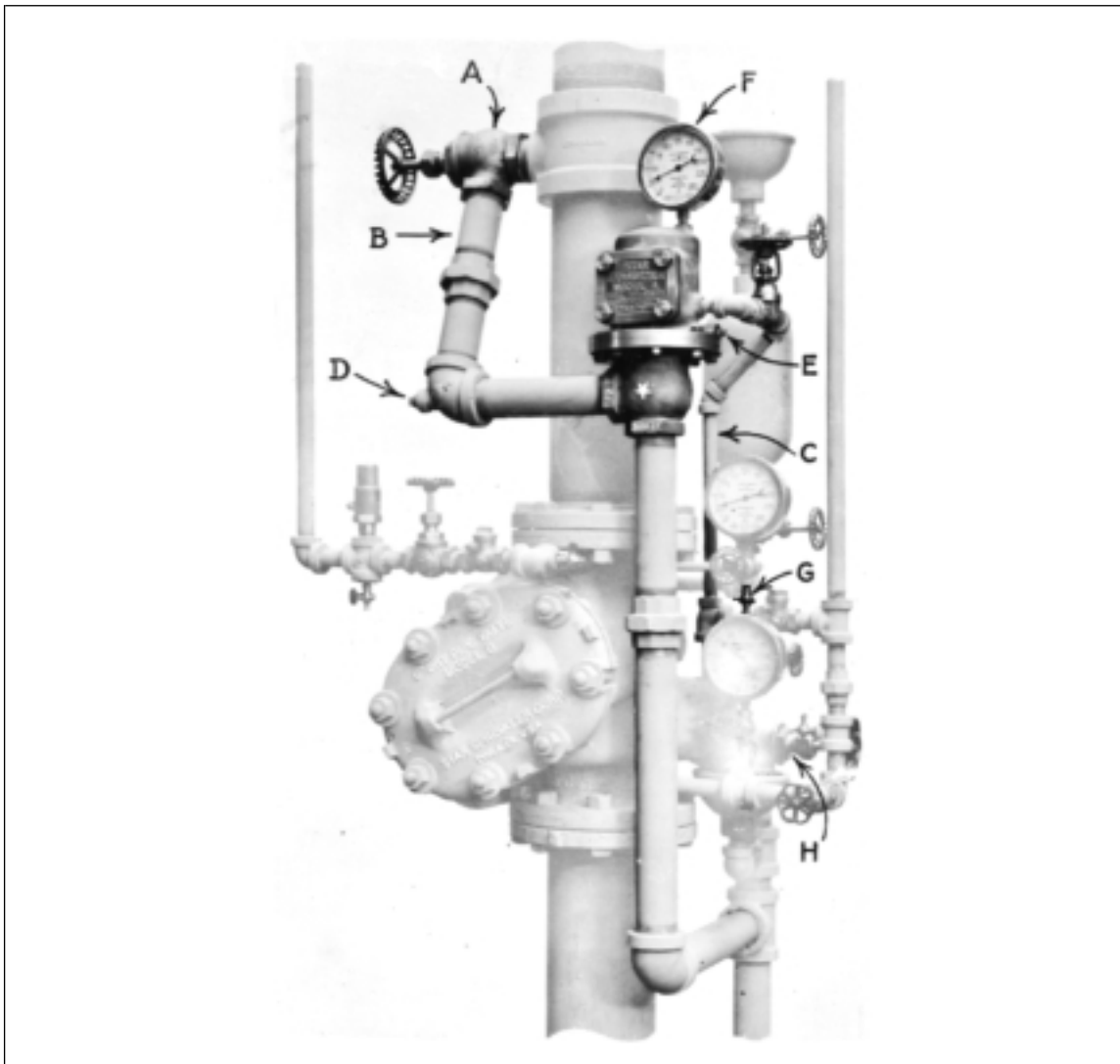

Fig. 145. Star exhausters

3. Drain the upper chamber by removing plug E; then replace the plug.
4. Remove the cover of the exhauster, and throw back the trip lever, forcing the auxiliary valve to its seat.
5. Replace cover of exhauster, being sure to make a tight joint. It is essential that this joint be absolutely tight as any leakage would retard action of the exhauster.
6. Open 2-inch valve A. See that exhauster is tight by noting if air is escaping. If any air escapes, close 2-inch valve A, and remove the discharge pipe from exhauster. The exhauster valve may be opened manually and the seat cleaned with a cloth swab bent at right angles to the seat. Replace the discharge pipe and open 2-inch valve A.
7. Note whether the gate F on the exhauster rises to the pressure in the system. If not, see 4 above or 2 under Maintenance.
8. Make sure that the main gate valve and the 2-inch valve A are wide open. Seal the main gate valve open.

3.22 Viking Tyden Model A Accelerator

Tyden Accelerator Model A 1924 TO 1927

Viking Corporation, Hastings, Mich.

DESCRIPTION

The Model A accelerator (Fig. 146) is designed for use with the Tyden Model A dry-pipe valve, but is adaptable for use with practically all types of differential dry-pipe valves. In set condition, air pressure enters system chamber 1 and passes to pressure chamber 2 via restriction orifice 3. Air pressure in the two chambers is equalized and spring 6 holds main valve 7 closed.

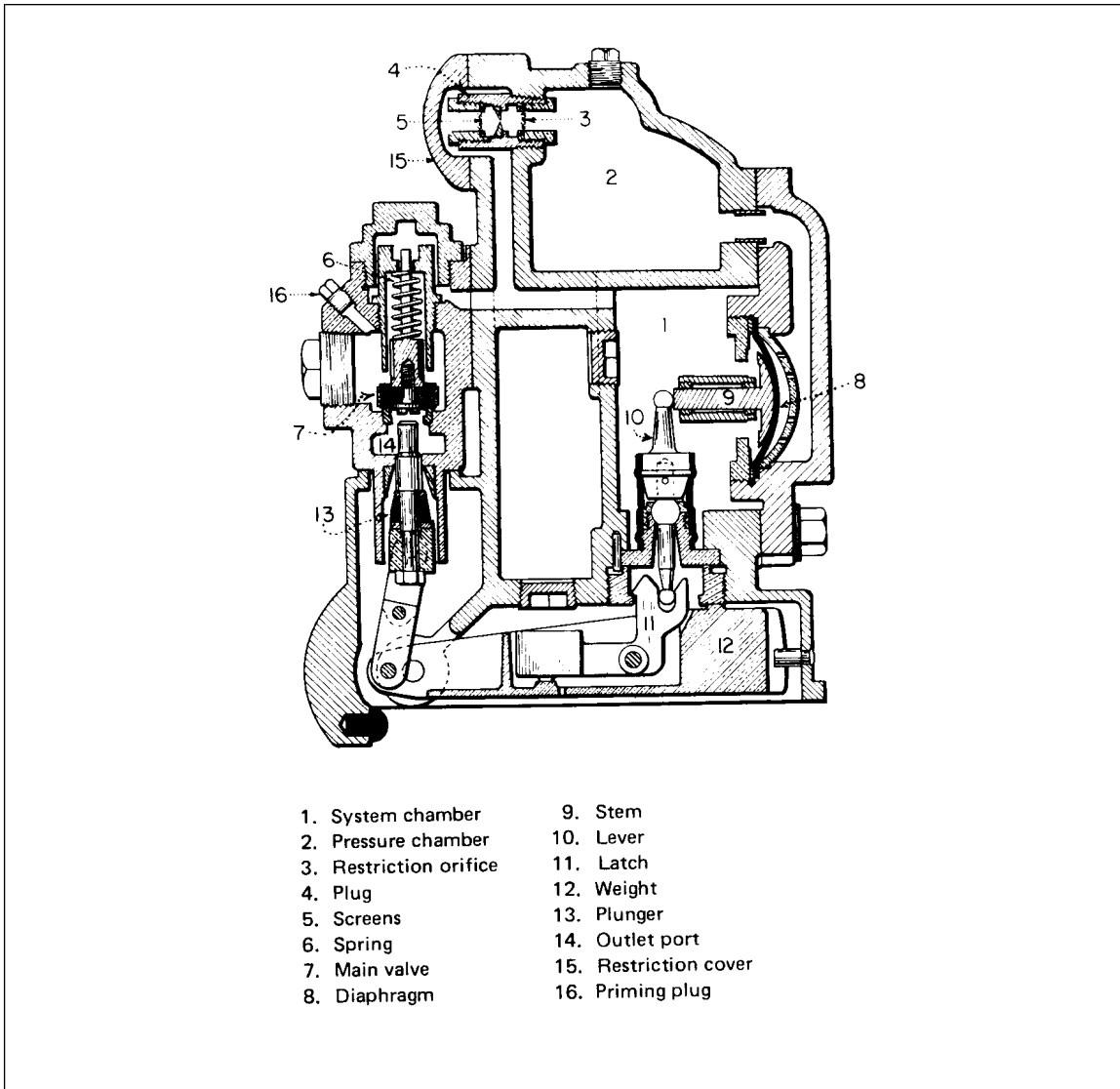

Fig. 146. Tyden Model A accelerator, internal view.

When sprinkler system pressure is reduced, pressure in system chamber 1 is also reduced. Pressure chamber 2 cannot relieve its pressure as quickly due to restriction orifice 3. Diaphragm 8 and stem 9 are forced forward moving lever 10 in a direction to release latch 11, allowing weight 12 to fall. When weight 12 falls, plunger 13 is forced upward opening main valve 7. Air pressure from the sprinkler system passes through outlet port 14 to the intermediate chamber of the dry valve, destroying the differential and causing the valve to operate.

INSPECTION

1. Check that air supply valve B (Fig. 147) is wide open.

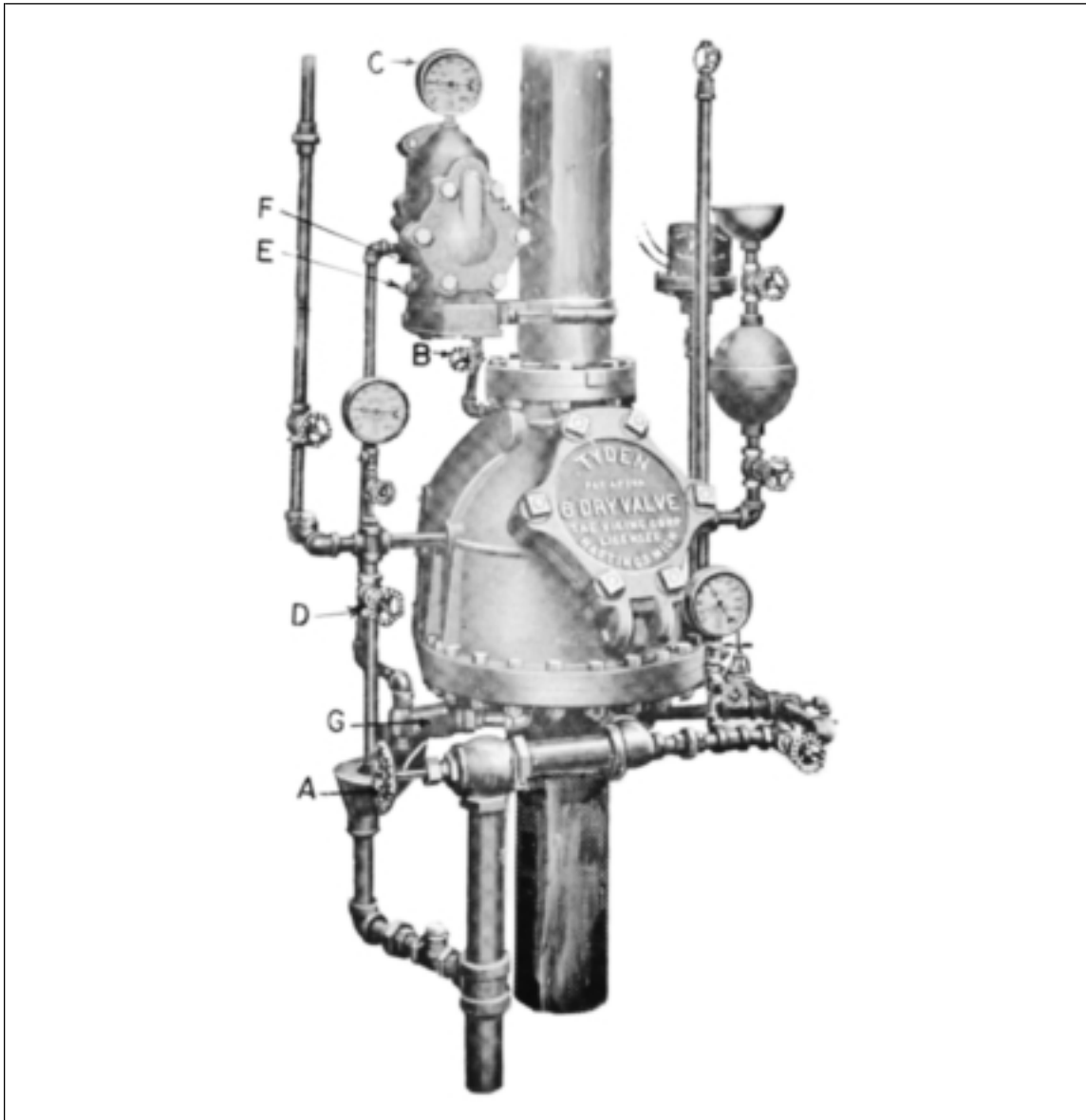

Fig. 147. Tyden Model A accelerator trim

2. Check that pressure gauge C indicates the same pressure as that in the sprinkler system. If the pressures differ, increase sprinkler pressure a few pounds and note if the pressure on gauge C increases a similar amount. (This will take 5 minutes.) If pressure gauge C does not increase, restriction orifice 3 or screens 4 are probably plugged. Close air supply valve B and remove restriction cover 15 and plug 4. Carefully clean screens 4 and restriction orifice 3, replacing plug 4 and restriction cover 15 when finished. (Make sure all joints are tight.) Open air supply valve B and note if pressure gauge C indicates the proper pressure. (This will take 5 min.) If the orifice is still obstructed, plug 4 with screens 5 and restriction orifice 3 should be sent to the manufacturer for repair. If this is done, make sure air supply valve B is closed tightly. The accelerator will be out of service, but the dry-pipe valve will still operate.

3. Open test valve D **slightly** and draw off any accumulated water. Close tightly when finished.

4. Check that the special automatic drip valve G is open and free to move by inserting an object similar to a pencil in the opening of the drip valve.
5. Check that air supply valve B is wide open.

TESTING (Without Tripping Dry Valve)

1. Close the main control valve supplying water to the system.
2. Open main drain valve A.
3. Close air supply valve B.
4. Loosen drain plug E; the accelerator should operate. Tighten after the accelerator has operated.
5. Close main drain valve A.
6. Follow steps 4 to 7 under **SETTING** to reset the accelerator.

SETTING

1. Close air supply valve B and set the dry-pipe valve following instructions in the appropriate data sheets or manufacturer's instructions. Do not open the main control valve until later.
2. Remove drain plugs E and F allowing water to drain from the two chambers. Replace tightly when finished.
3. Remove plug 4 and carefully clean screens 5 and restriction orifice 3. Replace plug 4 making sure the joint is tight, because any leakage would retard the operation of the accelerator.
4. Open air supply valve B. Make sure air is not leaking past the main valve 7 by listening at the drip valve. If air is leaking, remove priming plug 16 and add water to the level of plug opening; then replace priming plug.
5. Observe if the pressure on gauge C is rising. It will take approximately 5 minutes for the pressure to reach the level of air pressure in the sprinkler system.
6. **Open wide the main control valve.**
7. Test the water supply by opening main drain valve A.

3.23 Viking Tyden Model A Exhauster**Tyden Exhauster
Model A, 1927 to 1929**

Viking Corporation, Hastings, Michigan

DESCRIPTION

The Model A exhauster (Fig. 148) is designed for use with the Model A dry-pipe valve, but is adaptable for use with practically all types of dry valves. In set condition air pressure enters system chamber 1 and passes to pressure chamber 2 via restriction orifice 3. Pressure in the two chambers is equalized and spring 6 holds main valve 7 closed.

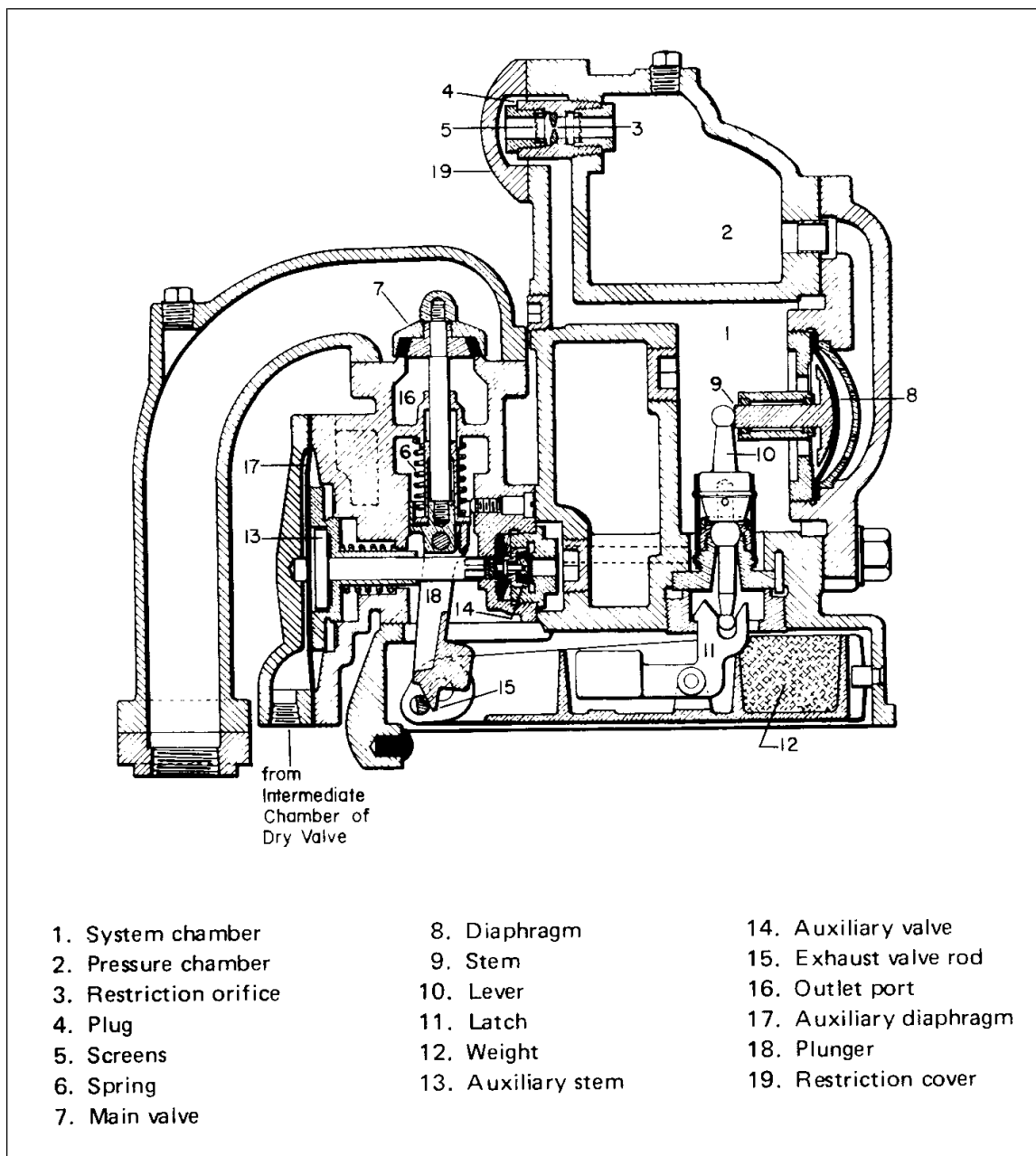

Fig. 148. Tyden Model A exhauster, internal view

When sprinkler system pressure is reduced, pressure in system chamber 1 is also reduced. Pressure chamber 2 cannot relieve its pressure as quickly due to restriction orifice 3. Diaphragm 8 and stem 9 are forced forward, moving lever 10 in a direction to release latch 11 and allowing weight 12 to fall. When weight 12 falls, plunger 18 is forced upwards opening main valve 7. Air pressure from the sprinkler system is exhausted through outlet port 16.

After the dry-pipe valve trips, water from the intermediate chamber of the dry valve enters the exhauster. Water pressure on auxiliary diaphragm 17 moves auxiliary stem 13 closing auxiliary valve 14. This releases exhaust valve rod 15 from its contact with weight 12. Spring 6 forces main valve 2 closed preventing waste of water through outlet port 16.

INSPECTING EXHAUSTER

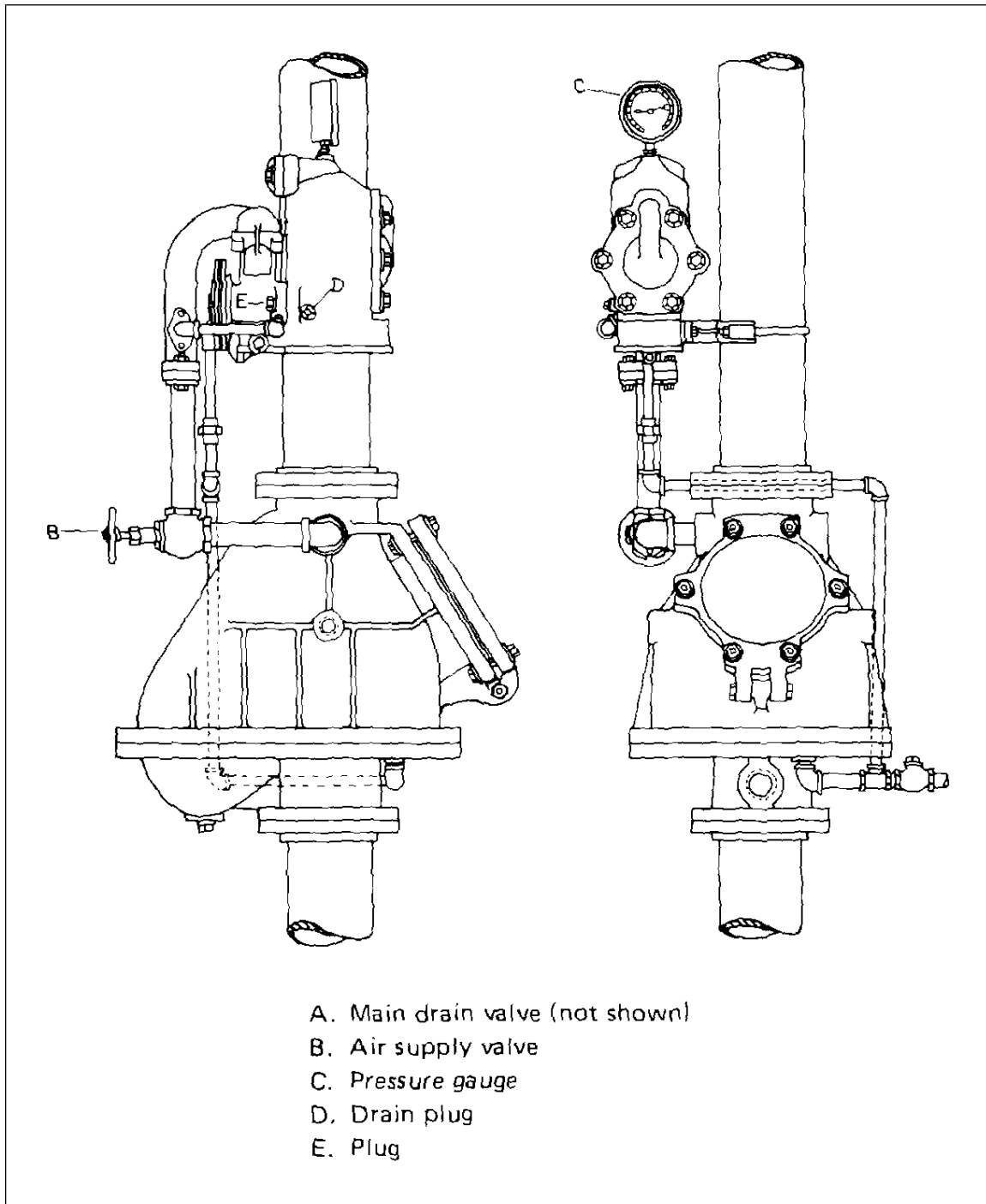

Fig. 149. Tyden Model A exhauster trim

1. Check that air supply valve B (Fig. 149) is wide open.
2. Check that pressure gauge C indicates the same pressure as that in the sprinkler system. If the pressures differ, increase sprinkler pressure a few pounds and note if the pressure on gauge C increases a similar amount. (This will take about 5 minutes.) If pressure gauge C does not increase, restriction orifice 3 or screens 4 are probably plugged. Close air supply valve B and remove restriction cover 19 and plug 4. Carefully clean screens 4 and restriction orifice 3, replacing plug 4 and restriction cover 19 when finished. (Make sure all joints are tight.) Open air supply valve B and note if pressure gauge C indicates the proper pressure. (This

will also take about 5 minutes.) If the orifice is still obstructed, plug 4 with screen 5 and restriction orifice 3 should be sent to the manufacturer for repair. Make sure air supply valve B is closed tightly. The accelerator will be out of service, but the dry-pipe valve will still operate.

3. Check priming water level in the dry valve. Priming water should never be allowed to reach the level of air supply valve B. Open drain plug D and draw off any accumulated water. Close tightly when finished.
4. Check that the special automatic trip valve is open and free to move by inserting an object similar to a pencil in the opening of the drip valve.
5. Check that air supply valve B is wide open.

TESTING

(Without Tripping Dry-Pipe Valve)

1. Close the main control valve supplying water to the system.
2. Open the main drain valve A (not shown on sketch).
3. Close air supply valve B.
4. Loosen drain plug E; the accelerator should operate. Tighten drain plug E after the accelerator operates. Loosen drain plug D to release air from pressure chamber 2. Tighten when finished.
5. Close main drain valve A.
6. Follow steps 4 to 7 under **SETTING** to reset the accelerator.

SETTING

1. Close air supply valve B and set the dry-pipe valve following instructions in the appropriate data sheet or manufacturer's instructions. Do not open the main control valve until later.
2. Remove drain plug D, allowing water to drain from pressure chamber 2. Replace tightly when finished.
3. Remove plug 4 and carefully clean screens 5 and restriction orifice 3. Replace plug 4 making sure the joint is tight, because any leakage would retard the operation of the accelerator.
4. Raise weight 12 until it engages its latch. Open air supply valve B. Make sure air is not leaking past main valve 7 by listening at exhaust port 16. If leakage is detected, main valve 7 should be cleaned. Open air supply valve B.
5. Observe if pressure on gauge C is rising. It will take approximately 5 minutes for the pressure to reach the level of air pressure in the sprinkler system.
6. **Open wide the main control valve.**
7. Test the water supply by opening main drain valve A.

3.24 Viking Tyden Model B Accelerator

Tyden Accelerator Model B, 1932 TO DATE

Viking Corporation, Hastings, Mich.

DESCRIPTION

Viking Model B accelerator (Fig. 150) may be used with practically any type of differential dry-pipe valve. Air pressure from the sprinkler system enters lower chamber 1 and passes to upper chamber 2 via restriction orifice 3. Pressure in the two chambers is equal and weight 7 is held in the raised position.

When system air pressure drops, pressure in lower chamber 1 also drops. Upper chamber 2 cannot relieve its pressure as fast as lower chamber 1 due to restriction orifice 3. This excess pressure forces main diaphragm 8 and main plunger 9 down raising releasing lever 10 and allowing weight 7 to fall. Weight 7 strikes plunger 12 which breaks glass strut 13. Valve plate 14 drops, allowing system pressure to enter the plunger housing. System pressure now passes through the accelerator to the intermediate chamber of the dry valve, destroying its differential and causing it to trip.

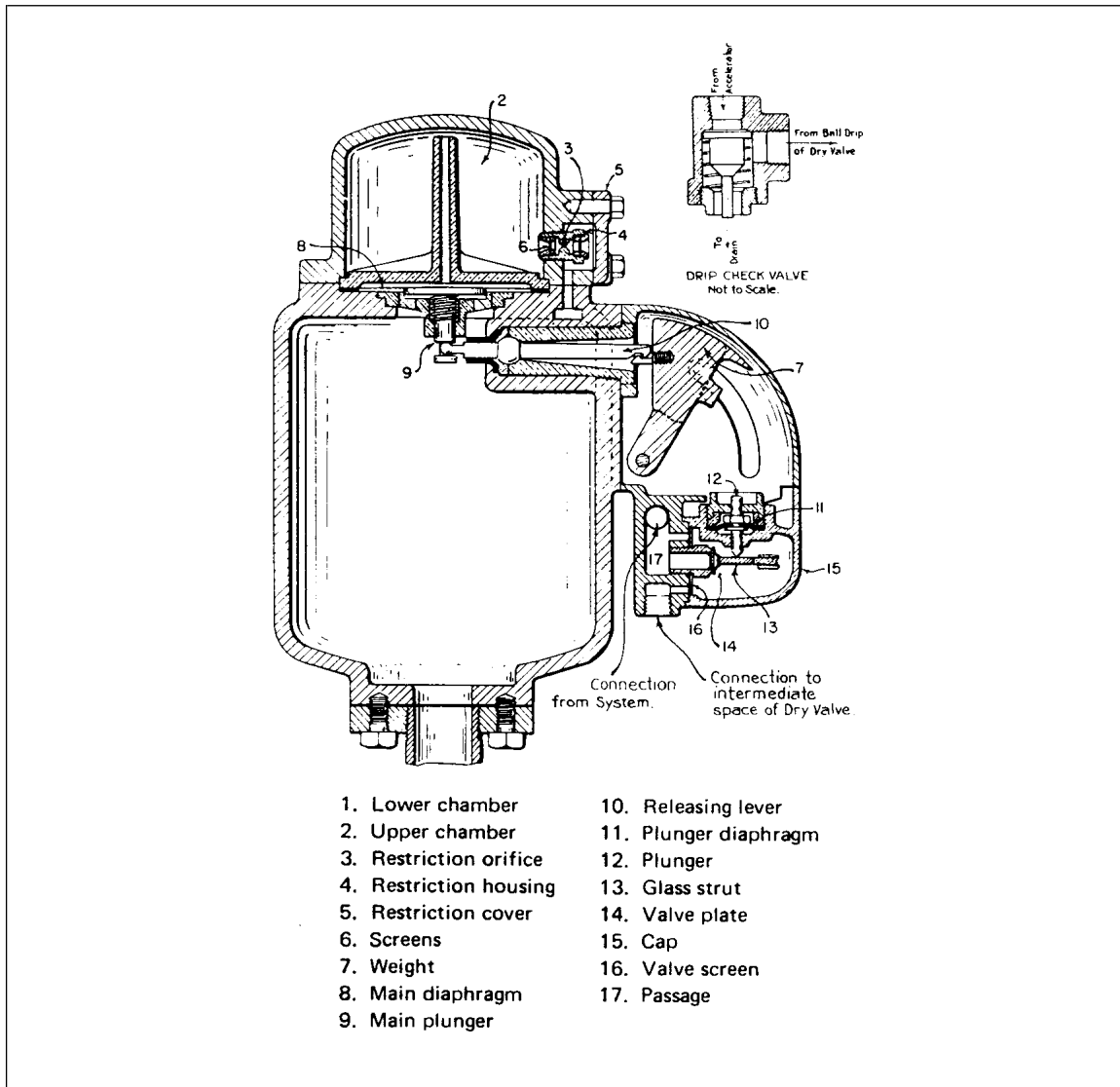

Fig. 150. Tyden Model B accelerator, internal view.

INSPECTION

1. Check that air supply valve B (Fig. 151) is wide open.
2. Check that pressure gauge C indicates the same pressure as that in sprinkler system. If the pressures differ, increase sprinkler pressure a few pounds and note if pressure on gauge C increases a similar amount. If pressure on gauge C does not increase, restriction orifice 3 or screens 6 are probably plugged. Close air supply valve B and remove restriction cover 5 and restriction housing 4. Carefully clean screens 6 and restriction orifice 3 which is contained in restriction housing 4. Replace restriction housing 4 and restriction cover 5 making sure all joints are tight. Open air supply valve B and note if pressure gauge C is at the proper pressure. (This will take about 2 minutes.) If the orifice is still plugged, restriction housing 4 with screens 6 should be sent to the manufacturer for repair. The accelerator will be sent out of service, but the dry pipe valve will operate.
3. Open test valve D **slightly** and draw off any accumulated water. Close tightly when finished. Open drain plugs E and F and drain any accumulated water.
4. Check that drip valve G is open and free to move.
5. Check that air supply valve B is wide open.

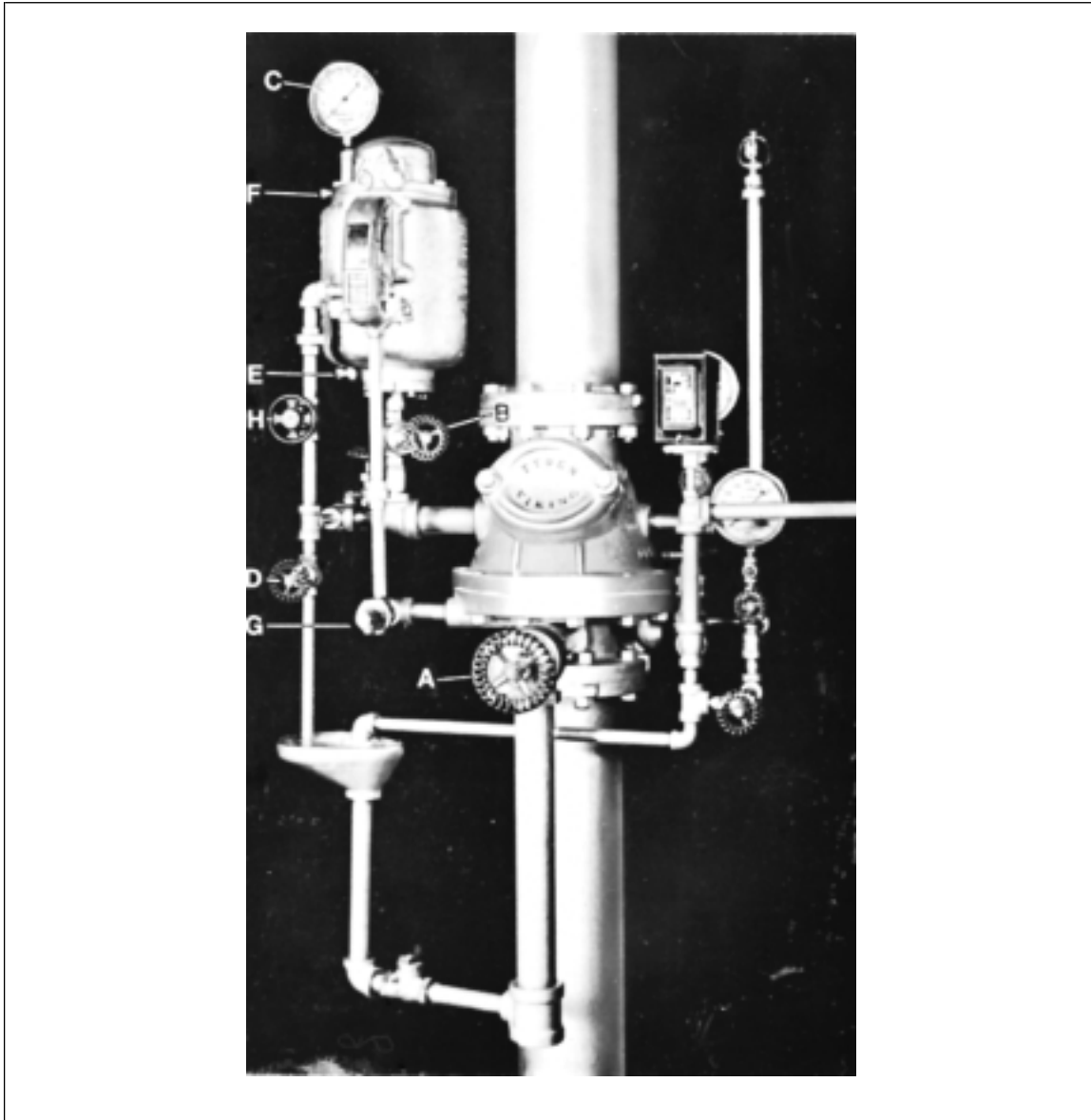

Fig. 151. Tyden Model B accelerator trim.

TESTING

(Without tripping accelerator)

1. Remove cap 15 so that glass strut 13 is not broken.
2. Close air supply valve B.
3. Close the main control valve supplying water to the system.
4. Open main drain valve A.
5. Loosen plug E until weight 7 drops. This indicates the accelerator is operating properly. Tighten plug E and raise weight 7 until it latches in the raised position.
6. Close main drain valve A.
7. Follow steps 5 to 7 as outlined under **SETTING**.

SETTING

1. Close air supply valve B and set the dry valve, following instructions in the appropriate data sheet or manufacturer's instructions. Do not open the main control valve until later.
2. Remove drain plugs E and F on the accelerator and allow water to drain; replace when finished.
3. Swing weight 7 up until it latches on releasing lever 10.
4. Remove cap 15 and replace glass strut 13. Clean valve screen 16 and replace cap 15 when finished.
5. Open air supply valve B and check that valve H is open.
6. **Open wide the main control valve.**
7. Test the water supply by opening main drain valve A.

3.25 Viking Tyden Model B Exhauster**Tyden Exhauster
Model B 1929 to 1932**

Viking Corp., Hastings, Mich.

DESCRIPTION

The Model B exhauster (Fig. 152) is similar to its predecessor, the Model A, and is designed for use with the Tyden Model A dry valve, but may be used with practically all types of dry valves. In set condition air pressure from the sprinkler system enters the exhauster and passes through port 3 to lower chamber 2. Air pressure also enters upper chamber 1 through restriction orifice 4. Pressure in the two chambers is equalized and diaphragm spring 11 holds plunger 12 up, allowing a series of levers and hooks to hold weight 8 in the raised position. Spring 9 holds main valve 10 closed.

When sprinkler system pressure is reduced, air pressure in lower chamber 2 is also reduced. Upper chamber 1 cannot relieve its pressure as quickly due to restriction orifice 4. Diaphragm 13 and plunger 12 are forced down, releasing latch 14. As latch 14 falls, the hook on latch rod 15 is engaged lifting latch rod 15 and lower latch 16 freeing weight 8. Weight 8 falls and main valve 10 opens. Air pressure from the sprinkler system is exhausted through outlet port 17.

After the dry-pipe valve trips, water from the intermediate chamber of the dry valve enters the exhauster. Water pressure on auxiliary diaphragm 18 moves auxiliary stem 19 forward closing auxiliary valve 20. Exhaust valve rod 21 is released from its contact with weight 8. Water pressure aided by spring 9 closes main valve 10 preventing waste of water through the exhaust port.

INSPECTION

1. Check that air supply valve B (Fig. 153) is wide open.
2. Check that pressure gauge C indicates the same pressure as that in the sprinkler system. If the pressures differ, increase sprinkler pressure a few pounds and note if the pressure on gauge C increases a similar amount. (This will take about 5 minutes.) If pressure on gauge C does not increase, restriction orifice 4 or screens 5 are plugged. Close air supply valve B and remove restriction cover 7 and restriction housing 6. Carefully clean restriction orifice 4 and screens 5, replacing restriction housing 6 when finished. Replace restriction cover 7 and open air supply valve B. Pressure gauge C should slowly reach the same pressure as that in the sprinkler system. (This will take about 8 minutes.) If restriction orifice 4 or screens 5 are still plugged, the exhauster should be replaced with an approved model.
3. Check the level of priming water in the dry valve. Priming water should never reach the level of air supply valve B. Remove drain plug 22 and drain any accumulated water. Replace drain plug 22.
4. Check that air supply valve B is wide open.

TESTING (Without Tripping Dry-Pipe Valve)

1. Close the main control valve supplying water to the system.
2. Open main drain valve A (not shown in sketch).
3. Close air supply valve B.

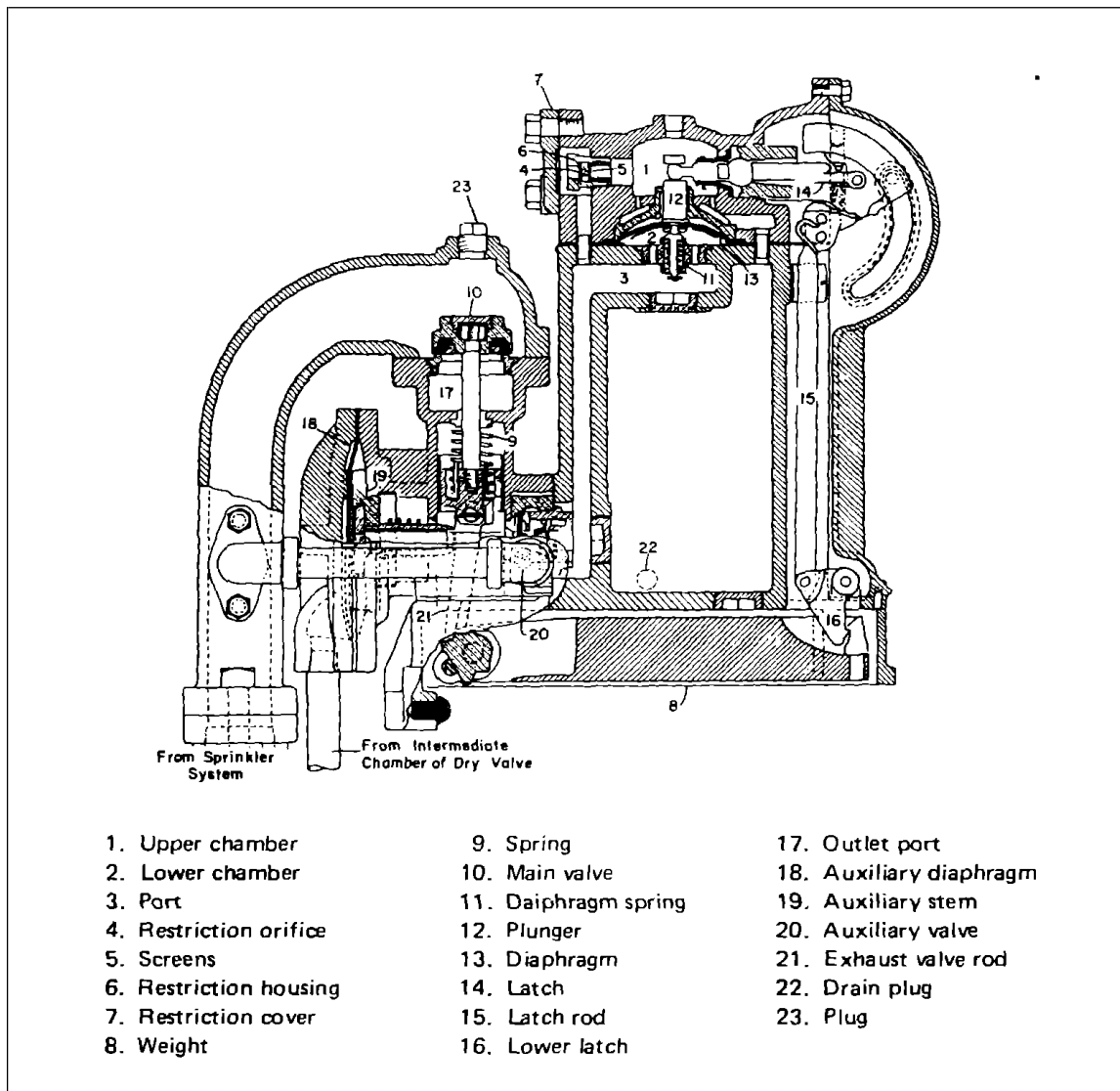

Fig. 152. Tyden Model B exhauster, internal view

4. Loosen plug 23, and pressure in lower chamber 2 will decrease causing the exhauster to operate. Tighten plug 23 after the exhauster operates.

5. Loosen drain plug 22 to release excess pressure from upper chamber 1; tighten drain plug 22 when finished.

6. Close main drain valve A.

7. Follow steps 4 to 8 under **SETTING** to reset the exhauster.

SETTING

1. Close air supply valve B and set the dry-pipe valve following procedures in the appropriate data sheet or manufacturer's instructions. Do not open the main control valve until later.

2. Remove drain plug 22 allowing water to drain. Replace tightly when water ceases to flow.

3. Remove restriction cover 7 and restriction housing 6. Carefully clean restriction orifice 4 and screens 5. Replace restriction housing 6 and restriction cover 7, making sure all joints are tight.

4. Raise weight 8 and set the exhauster as shown in Fig. 152.

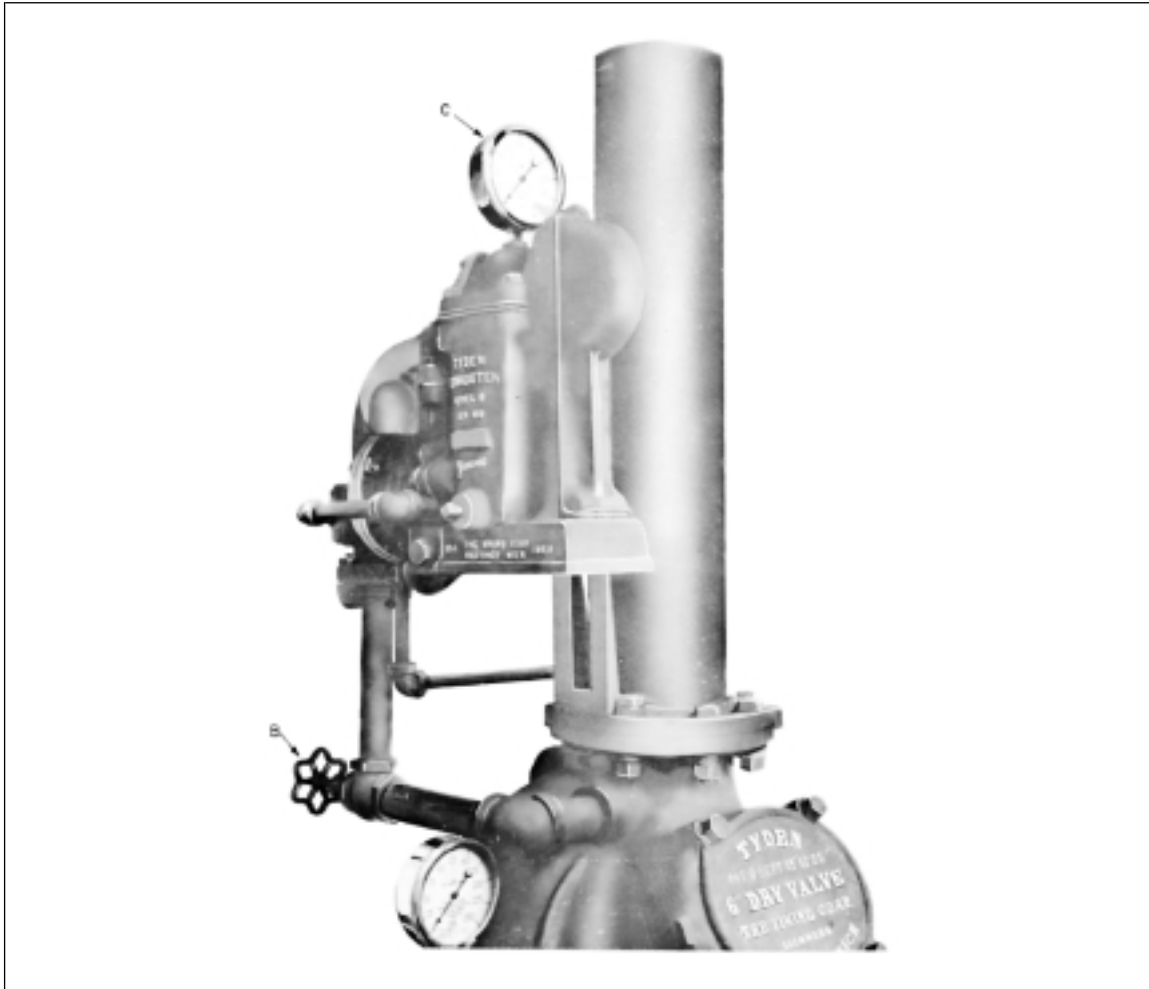

Fig. 153. Tyden Model B exhauster trim.

5. Open air supply valve B and make sure no air leaks past main valve 10 by listening at outlet port 17. If air is escaping, main valve 10 should be cleaned.
6. Check that the pressure on gauge C slowly reaches the level of air pressure in the sprinkler system. (This will take about 8 minutes.)
7. **Open wide the main control valve.**
8. Test the water supply by opening main drain valve A.

3.26 Viking Tyden Model C Air Pressure Maintenance Device

Tyden Model C Air Pressure Maintenance Device

Viking Corporation, Hastings, Michigan

The Tyden Model C Air Pressure Maintenance Device automatically maintains the air pressure in a dry-pipe system once the normal pressure has been established manually. The air supply for the device is taken from a source such as a shop air supply system, maintained continuously at a higher pressure than that required in the dry system. This device compensates for small leaks in the dry system, but will not retard the normal tripping operation of the dry-pipe valve. It is suitable for the maintenance of any pressure below 45 psi. in the piping supplied through one dry-pipe valve.

DESCRIPTION

The general arrangement of the device is shown in Fig. 154. The diaphragm chamber (1) is connected to the air valve outlet (3) through a horizontal check valve (4) and to the sprinkler system. The normally closed air valve (10) between the air inlet to the device (5) and the sprinkler system is operated through a mechanical lever system (6) by the movement of the diaphragm (7) which is positioned by the air pressure in the sprinkler piping. The predetermined pressures at which the air valve opens and closes are regulated by adjusting nuts (11) and (12) respectively.

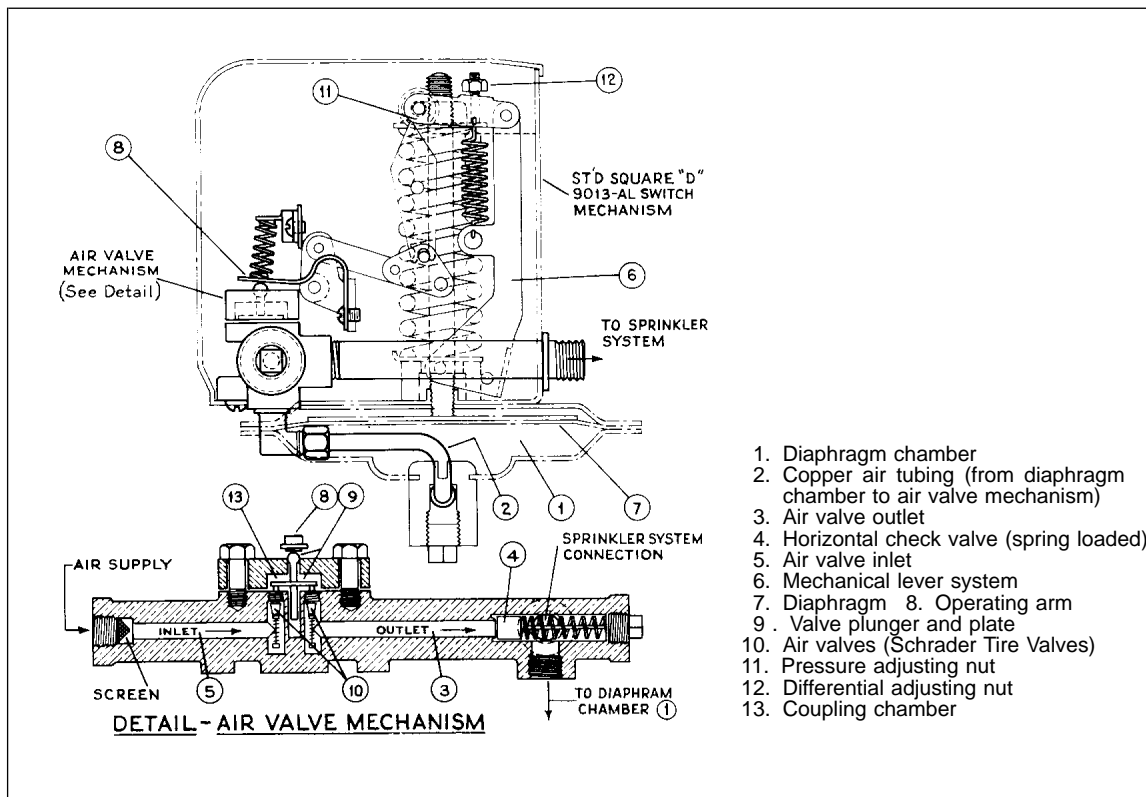

Fig. 154. Viking Tyden Model C Air Pressure Maintenance Device

OPERATION

A reduction of about 5 lb. in the sprinkler system air pressure to the preset point causes the diaphragm to drop, transmitting the motion through a lever system to push down arm (8) and plunger (9) which open the two Schrader tire valves operating in series (10) allowing air to pass into the sprinkler piping. The ball-shaped end of plunger (9) seats itself to prevent air leakage from the coupling chamber (13) when the air valve is opened. There is usually a small amount of leakage at this point which does not affect the operation of the device. The upward movement of the diaphragm raises the lever which permits the Schrader valves to close when the air pressure has been restored to normal. An integral check valve (4) in the device prevents loss of air in the reverse direction and tripping of the dry valve should the supply pressure be low when the air valve is opened automatically. Adjustments in the cut-in and cut-out points can be made by making slight changes in the positions of nuts (11) and (12) while listening for the operation of the device.

INSTALLATION

The air pressure maintenance device is installed in a line by-passing the manual air supply control valves. Provide control valves (renewable disc type) at the inlet and outlet of the device so that it may be removed from the line for repairs. Provide a relief valve at the dry-pipe valve set to relieve at 5 lb. in excess of the maximum air pressure ordinarily maintained in the dry-pipe system.

Normal maintenance and inspection of the dry-pipe valve system is required even though a pressure maintenance device has been installed.

MAINTENANCE

No special maintenance of the device is required.

TESTING

Test the air maintenance device when the dry-pipe valve is trip-tested. Draw down the air pressure in the system and determine by listening at the device while observing the air pressure gage that the air valve opens at the proper pressure setting. Permit the last small amount of air to be added through the air maintenance device when the dry system is repressured to determine that it cuts off properly.

4.0 DELUGE AND PREACTION SYSTEMS**4.1 Automatic (ASCOA) Model 142 (Suprotex)**

**Deluge Systems and Preaction Sprinkler Systems
WITH "AUTOMATIC" WATER CONTROL VALVE MODEL 142
6-Inch
1947**

Table

<i>Installer</i>	<i>Preaction System</i>	<i>Deluge System</i>
"Automatic" Sprinkler Corp. of America	Suprotex Sprinkler System	Suprotex Deluge System
For general description, application and installation of these types of systems, see Sprinkler Rules and Approved Equipment manual.		

DESCRIPTION**Automatic Water Control Valve (See Fig. 155 and 156)**

The Model 142 automatic water control valve is essentially a single swing clapper check valve in which the rubber-faced clapper (76-603) is held on its seat ring (76-635) by clapper latch (140-604). The clapper latch (140-604) is hinged to the body (140-601) and attached to a lever system consisting of link (140-621), adjustable screw eye (140-623), metal stem (140-625), diaphragm (140-626), and latch arm (142-10). This lever system forms an airtight connection out through the body (140-601) to the weight guide rod (142-15).

The clapper latch (140-604) also has a projection which causes alarm valve arm (140-605) to hold the alarm valve (140-608) on its seat (140-636) when the automatic water control valve is set.

Releasing Mechanism (See Fig. 155)

The releasing mechanism for the automatic water control valve is mounted on the side of body (140-601). The airtight enclosing box (142-2) contains the mercury checks (77-400), compensating vents (90-100), and the weight release lever assembly. The weight (141-102), weight latch (141-107), and weight guide rod (142-15) are mounted on the side of the enclosing box (142-2) and covered with a removable sheet metal cover (142-25).

One to four mercury checks and connecting manifold (See Fig. 157) are located in a suitably drilled stainless steel block (77-400). The mercury checks have two chambers of unequal area connected by a small orifice tube. The inlet chamber is connected to a circuit of heat actuated devices (HADs) through copper tubing, equipped at the check with a calibrated orifice compensating vent (90-100). The outlet chamber is connected to the manifold.

The mercury checks prevent pressure from HADs over the fire from being dissipated to other HADs of the system. They also resist small pressure changes due to normal temperature fluctuations so that these changes are taken care of by the compensating vents (90-100).

In preaction sprinkler systems, the manifold is connected by copper tubing to one side of a double acting diaphragm having a calibrated orifice compensating vent (90-100). The other side of the diaphragm is vented to the airtight enclosing box (142-2). In deluge systems a single acting diaphragm is used. In either system this diaphragm controls the releasing levers for the weight (141-102).

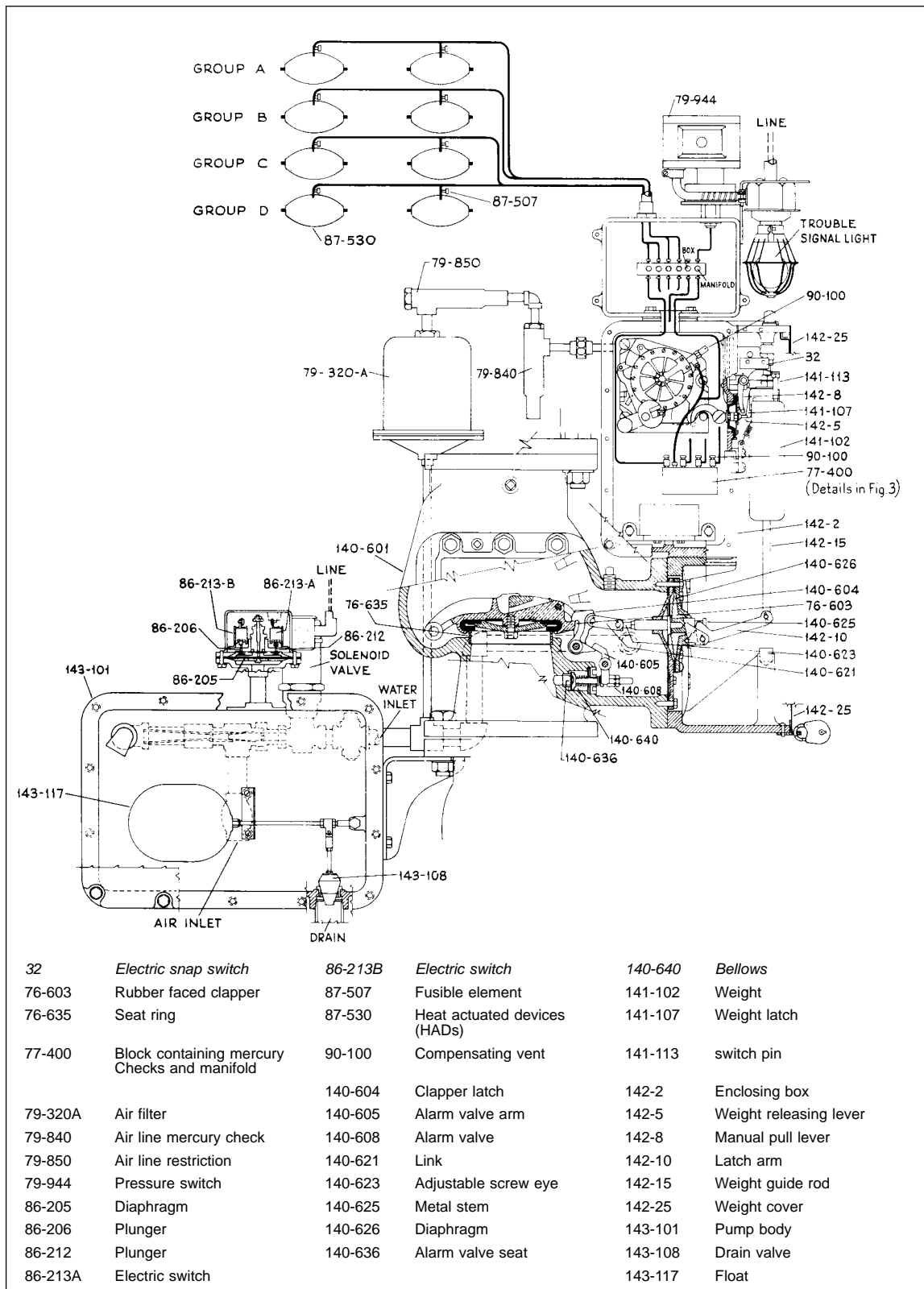

Fig. 155. "Automatic" Water Control Valve Model 142.

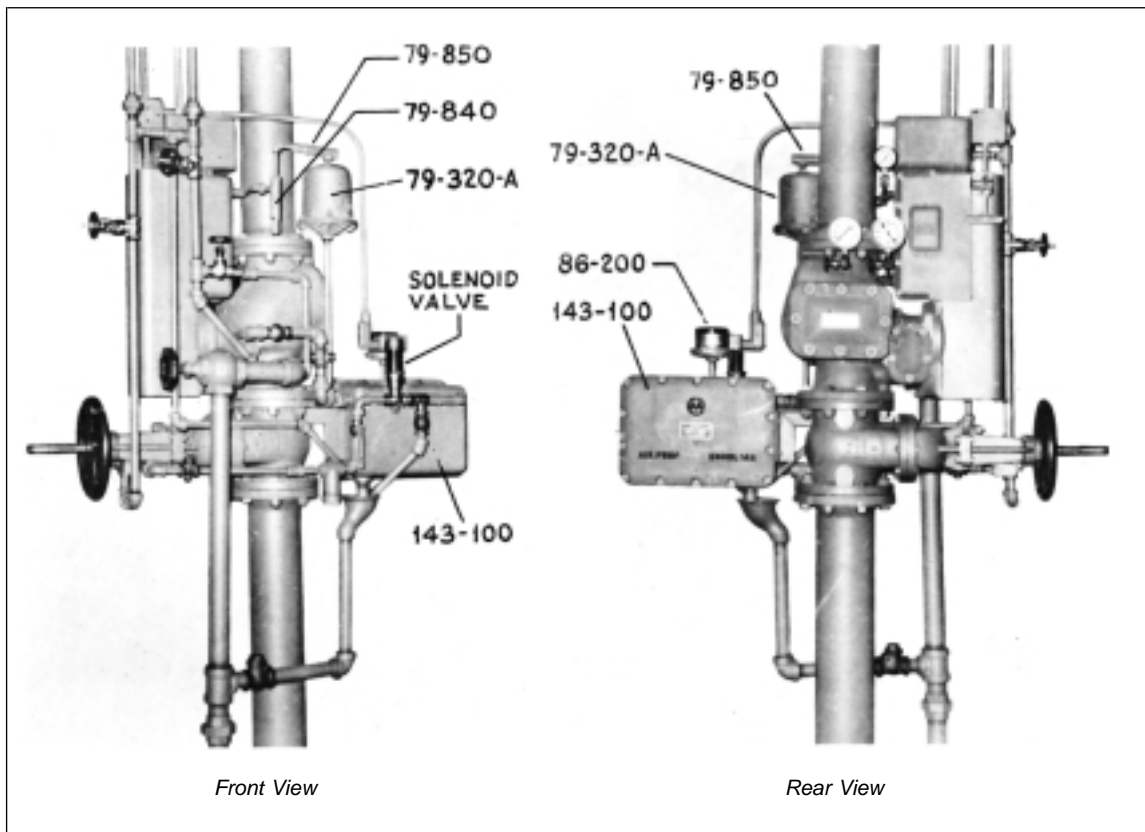

Fig. 156. 6-Inch "Automatic" Water Control Valve Model 142 — External View.

On the side of weight (141-102) is a pivoted bronze weight latch (141-107) held in position by a spring. When the weight (141-102) is in the set position, the toe of the weight latch (141-107) engages weight releasing lever (142-5) of the automatic releasing mechanism that extends out of the airtight enclosing box (142-2).

The manual release is arranged so that when the handle is pulled, manual pull lever (142-8) compresses the spring holding the weight latch (141-107) in position and the toe of the latch no longer engages with weight releasing lever (142-5).

On the top of the weight (141-102) is a switch pin (141-113) which, when the weight (141-102) is in the set position, engages a lever from an electric switch (32) and keeps the switch closed.

When the weight releasing lever (142-5) is allowed to pivot downward or the manual release is pulled, weight latch (141-107) no longer engages lever (142-5) permitting the weight to slide down the weight guide rod (142-15) to the latch arm (142-10) which unlatches the rubber-faced clapper (76-603) and opens the alarm valve (140-608).

Actuating Mechanism (See Fig. 155)

Automatic control of the release mechanism is by heat actuated devices (HADs) (87-530) which are pneumatic thermostats located so as to detect fires in the area protected. These thermostats operate on a rate of rise of temperature determined by the area of the orifice in the compensating vent (90-100) and the amount of mercury placed in the mercury check (77-400). The area of the orifices in the vents and the amount of mercury in the check valve are varied so that the automatic control valve will not trip because of normal temperature changes or any special operating temperature changes such as when an oven is brought up to operating temperature.

A fusible element (87-507) is provided as a part of each HAD (87-530) for fixed temperature operation of the release mechanism.

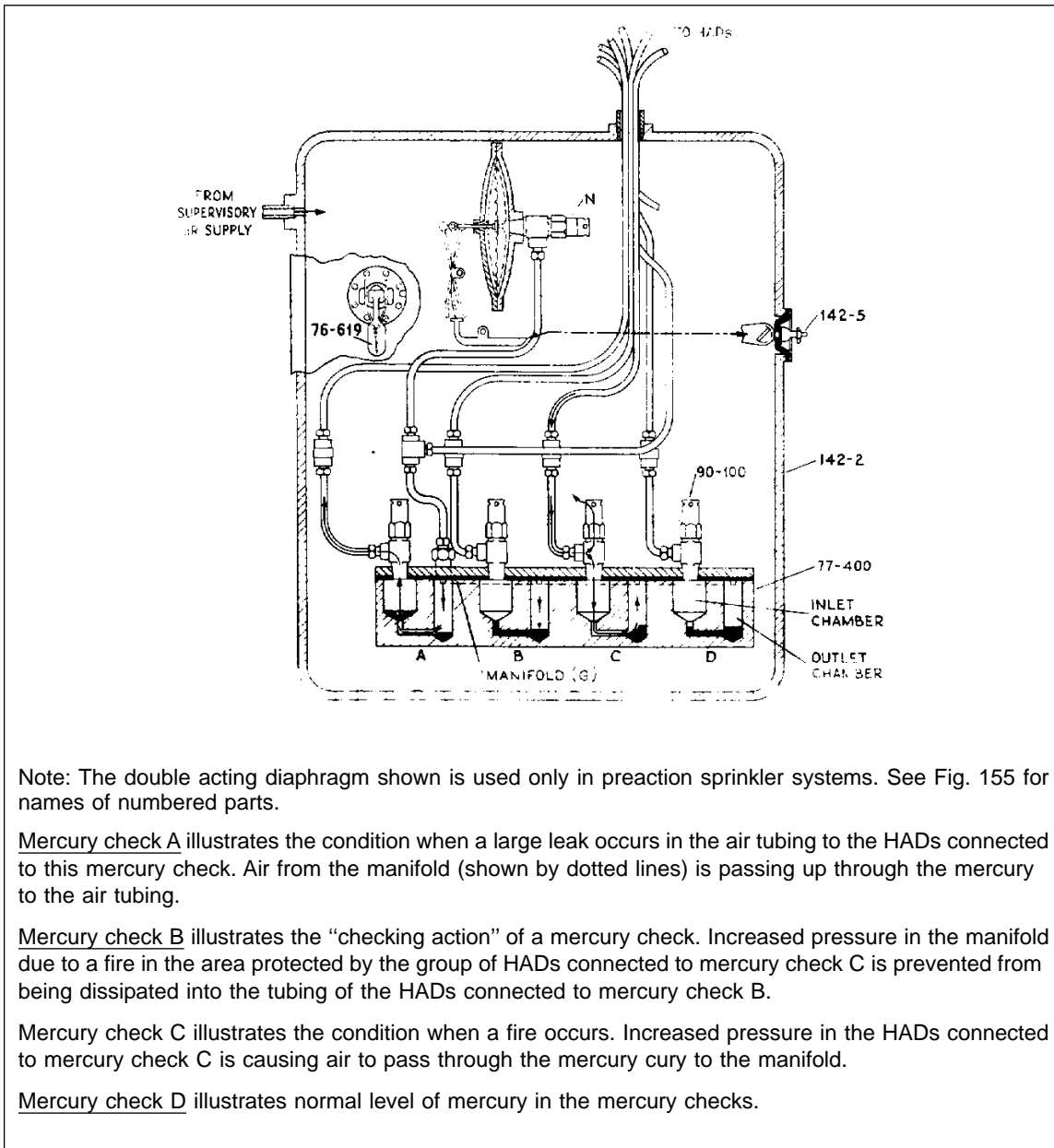

Note: The double acting diaphragm shown is used only in preaction sprinkler systems. See Fig. 155 for names of numbered parts.

Mercury check A illustrates the condition when a large leak occurs in the air tubing to the HADs connected to this mercury check. Air from the manifold (shown by dotted lines) is passing up through the mercury to the air tubing.

Mercury check B illustrates the “checking action” of a mercury check. Increased pressure in the manifold due to a fire in the area protected by the group of HADs connected to mercury check C is prevented from being dissipated into the tubing of the HADs connected to mercury check B.

Mercury check C illustrates the condition when a fire occurs. Increased pressure in the HADs connected to mercury check C is causing air to pass through the mercury to the manifold.

Mercury check D illustrates normal level of mercury in the mercury checks.

Fig. 157. Details of Action of Mercury Checks (Diagrammatic)

The HADs (87-530) are hollow brass chambers. Heat from a fire is absorbed by the brass shell and is conducted to the air inside. The air expands creating a pressure impulse in the tubing which passes through the mercury check in the stainless steel block (77-400) on the circuit to the diaphragm which operates the automatic release mechanism.

HAD's having a polyurethane enamel and epoxy coating are acceptable for use in the following corrosive environments:

Acetic acid, 2%	Potassium hydroxide
Hydrochloric acid, 20%	Acetone
Hydrochloric acid, 2%	Latex
Nitric acid, 10%	Motor oil, 10W
Tall oil fatty acid (Sylfat 94)	Phenol, 10%
All common alkalis and solvents	Aircraft hydraulic fluid
Bromine water	Sodium chloride, 25%
Chlorine Water	Sodium hypochlorite, Cl. 10%
Cutting oil	Sodium hypochlorite, Cl. 6%
Formaldehyde, 20%	Household detergent
Gasoline, regular	Water, deionized
Gasoline, premium	Water, sea
Hydrogen sulfide (Gas)	Water, tap
Methyl isobutyl ketone	Methyl ethyl ketone

Manual control of the release mechanism is through manual pull lever (142-8) which moves weight latch (141-107) when the manual control handle is pulled. When weight latch (141-107) moves, weight (141-102) is released.

Supervisory Air Pump Model 143 (See Fig. 155)

Supervisory air pressure at 1 ½ psi is supplied by an automatically controlled pump. This pump is hydraulically operated. In both the preaction and deluge systems, supervisory air pressure is supplied to the HADs (87-530), connecting tubing, and automatic release mechanism. In the preaction sprinkler system, supervisory air is also supplied to the sprinkler piping.

This pump is controlled by a diaphragm (86-205) connected by two different length plungers (86-206 and 86-212) to two normally open electric switches (86-213A and 86-213B). When the pressure in the pump body (143-101) drops, diaphragm (86-205) moves down carrying the plungers (86-206 and 86-212) with it. When the pressure reaches 1 psi, plunger (86-212) allows switch (86-213A) to close completing the electric circuit to the solenoid valve causing it to open. Water then may enter the venturi and draw air from the air inlet into the pump body (143-101) to increase the pressure. As the water level rises, float (143-117) rises and opens drain valve (143-108) to allow excess water to drain off. As the air pressure rises diaphragm (86-205) moves up and at 1 ½ psi opens switch (86-213A) causing the solenoid valve to close, shutting off the flow of water and air into the pump body.

Should the pump not be able to supply sufficient air, the pressure will continue to drop and the diaphragm (86-205) will move down sufficiently so that switch (86-213B) will close and sound a low pressure alarm at ½ psi.

Auxiliary Equipment

Details of air filter (79-320A), air line restriction (79-850), air line mercury check (79-840) and monitor switch or monitor valve are covered in Data Sheet 2-65.

OPERATION (Figs. 155 and 157)

When Fire Occurs

With either a preaction sprinkler system or deluge system, heat from a fire acts upon the HADs (87-530) causing an increase in air pressure in the tubing to the inlet chamber of the mercury check for that group of HADs. When this pressure increases at a greater rate than can be vented through the compensating vent (90-100) on the mercury check, air passes through the mercury and manifold in stainless steel block (77-400) to one side of the diaphragm in the enclosing box (142-2). The increase in pressure in the manifold is prevented from dissipating into other groups of HADs by the check action of the other mercury checks. When the air passing through the mercury causes the pressure of one side of the diaphragm to increase at a greater rate than can be discharged through the compensating vent (N, Fig. 157) at the diaphragm, the diaphragm will move. Movement of the diaphragm allows weight releasing lever (142-5) to pivot, and release weight (141-102). Weight (141-102) then slides down weight guide rod (142-15) to release the clapper latch

(140-604) permitting rubber-faced clapper (76-603) and alarm valve (140-608) to open. When the clapper (76-603) opens, water flows into the sprinkler piping and to the water motor alarm.

When Supervisory Air Leaks from Air Tubing

With a preaction sprinkler system, if leakage of supervisory air from the air tubing occurs at a rate faster than air from the enclosing box (142-2) can be supplied through the compensating vent (90-100) at the mercury check, pressure in the inlet chamber of the mercury check is reduced. The higher pressure in the manifold then forces air through the mercury and out to the air tubing. The supervisory pressure in the manifold is thus lowered faster than it can be replenished from the enclosing box (142-2) through the compensating vent (N, Fig. 157) on the diaphragm. This reduces the pressure on one side of the diaphragm causing it to move and trip the valve in the same manner as when a fire occurs. Thus, the valve fails safe and the system then acts as a wet pipe system.

If leakage of supervisory air from the air tubing occurs at a rate slower than air from the enclosing box can be supplied through the compensating vent (90-100) at the mercury check, the pressure in the upper chamber of the mercury check will not be reduced. When the pressure in the enclosing box reaches 1 lb., the air pump will start and replenish the lost pressure. Should the air pump fail, the supervisory air will continue to leak out with further reduction in pressure. When the pressure reaches ½ lb., the trouble alarm will sound. With this type of slow leak, the automatic water control valve will not trip.

With a deluge system the only difference is that the lowering of pressure in the manifold by a large leak in the air tubing does not cause the water control valve to trip since the diaphragm can move in only one direction. In deluge systems the manifold is connected to the pressure switch and a trouble alarm and signal light. When the pressure in the manifold is reduced because of leakage in the air tubing, the pressure switch (79-944) operates, completing the circuit to the trouble alarm and signal light.

A very rapid leak in the air tubing can blow mercury out of a mercury check and carry it through the connecting tubing to some other location. This can occur with supervisory air pressures as low as 18 oz./sq. in. If the copper tubing connecting the HAD's has been physically damaged sufficiently to result in a rapid loss in air pressure, examine the mercury check setting of that particular system to ensure that no significant amount of mercury was moved.

Leakage of Supervisory Air From Sprinkler Piping

With a preaction sprinkler system the leakage of supervisory air from the sprinkler piping causes the automatically controlled pump to start when the pressure has been reduced to 1 lb. If the leak is such that the pump can supply the air and raise the pressure to the normal 1 ½ lb., the pump will shut off. If the leak is beyond the capacity of the pump or if the pump fails, the pressure switch on the pump will cause the trouble alarm to sound should the pressure in the sprinkler piping be reduced to ½ lb.

The automatic water control valve will not be tripped by loss of supervisory air from the sprinkler piping. By this arrangement, an accidental pipe break in a preaction sprinkler system will not cause "sprinkler leakage" damage.

SETTING

1. Close the indicator post gate or O.S. & Y. valve for the system.
2. Close the stop-cock controlling the water to the air pump.
3. Close the valves in the pipes to the water siren (trouble alarm) and water motor gong.
4. Open the drain valve below the automatic water control valve.
5. Remove the cover from the automatic water control valve and clean the seat and rubber facing.
6. Place the clapper of the automatic control valve on its seat and replace the cover.
7. Remove the small cover marked "To Reset Remove Cover Pull Handle" from the metal cabinet housing the release mechanism and the cover (142-25) over the release weight. **Do Not Remove the Large Gasketed Cover.**
8. Simultaneously pull the reset lever below the small cover outward and raise the release weight until the latch on the side engages weight releasing lever (142-5). This operation automatically latches the water clapper shut. Release the reset lever.
9. Close the drain valve.

10. Open the stop-cock to supply water to the air pump.
11. When the air pump stops operating, open the indicator post gate or O.S. & Y. valve for the system slowly until the lever on the monitor valve or switch fits into the groove on the stem at the wide open position.
12. Replace the small cover and the cover over the release weight.
13. Open the valves in the pipes to the water motor gong and trouble siren.
14. Test the drain valve below the automatic water control valve. Then seal in the open position all manual water control valves that have been operated.
15. The system is now in service.

MAINTENANCE AND INSPECTION

The manufacturer or installer of these systems offers a maintenance and inspection service under various contract forms. Unless the plant has specialized personnel who can adequately test and maintain these systems, it is advisable for them to purchase one of these maintenance and inspection contracts. With these systems it is not usually practical for the plant mechanics to make anything other than minor adjustments and repairs. In order to avoid unnecessary damage to the systems, it is advised that unless the cause of trouble is readily apparent, the manufacturer or installer be contacted to make necessary repairs and adjustments.

The water motor alarm and trouble siren should be tested weekly. All manual control valves should be inspected weekly to make sure that they are in the wide open position.

The automatic water control valve should be testtripped annually.

If any part of the thermopneumatic system is exposed to freezing temperature, check the weight of alumina in the dehydrator annually. Where the thermopneumatic system is not exposed to freezing temperatures, the weight of the alumina should be checked every three years. Should the weight of the canister exceed 3 lb., replace the alumina or dry it out in an oven.

Procedure for Checking Supervisory Air (Test should be made at each FM inspection)

Note: The results of a test for checking supervisory air made under a sprinkler company inspection contract can be accepted in place of a test made by the Insured and witnessed by a Factory Mutual representative. Frequency of tests by either one or the other should be not less than the frequency of Factory Mutual inspections.

1. Close the indicator post gate or O.S. & Y. valve controlling water to the system.
2. Open the 2-inch drain below the automatic water control valve.
3. Open the cabinet containing the header for the air tubing (shown in Fig. 155 beside the trouble signal light).
- 4 a. In a preaction sprinkler system, loosen the plug on the header in the air line marked "manifold". There will be one of these plugs for each airtight cabinet containing mercury checks. Any one of these "manifold" plugs may be loosened for this test. As the plug is loosened and air escapes, note that the air pump starts. As soon as the air pump has started, immediately tighten the plug to prevent excessive loss of air and the tripping of the automatic water control valve.
 - b. With a deluge system, proceed as for a preaction sprinkler system except that the plug should remain loosened until the trouble siren sounds. As soon as the trouble siren has sounded, tighten the plug.
5. Close the 2-inch drain valve and open the indicator post gate or O.S. & Y. water control valve for the system. Seal control valves in the open position.

Procedure for Operational Tests (Tests should be made once a year)

1. In a preaction sprinkler system release the supervisory air in the sprinkler piping by means of the inspector's test connection at the end of the system and note that the air pump starts and the trouble siren sounds. Close the inspector's test connection as soon as the trouble siren sounds to avoid excessive loss of air.
2. Close the indicator post gate or O.S. & Y. valve controlling water to the system.
3. Open the 2-inch drain below the automatic water control valve.

4. With either a preaction sprinkler system or deluge system, apply the electric test set to one of the HADs in each group, noting the time required to trip the automatic release. Operation should occur within one minute. Reset the release weight as described under Step 8 of SETTING between the test on each group of HADs and after the final test. In areas where pyroxylin or other hazardous materials are stored or used in plant processes, immerse the HADs in a small container of hot water instead of using the electric heater.
 5. Wait about fifteen minutes to allow pressure in the thermopneumatic system to return to normal.
- Note: The results of annual operational tests made under a sprinkler company inspection contract can be accepted in place of tests made by the Insured and witnessed by a Factory Mutual representative.
6. Remove a fusible plug from one HAD in each group. In a preaction sprinkler system this will cause the automatic release of the automatic water control valve to trip. In a deluge system it will cause the trouble siren to sound.
 7. The fusible elements should be carefully replaced and the joints tested with a soap solution to make sure they are tight.
 8. Operate the release mechanism manually by pulling the hand mechanism.
 9. Examine the automatic water control valve internally and clean the clapper and seat.
 10. Return the system to service as described under SETTING.

4.2 Automatic (ASCOA) Model A

**Deluge Systems and Pre-Action Sprinkler Systems
(WITH AUTOMATIC WATER CONTROL VALVE MODEL A)**

- 3-Inch - 1919 to 1932
- 4-Inch - 1919 to 1931
- 6-Inch - 1927 to 1931
- 8-Inch - 1927 and 1928

<i>Installer</i>	<i>Pre-Action System</i>	<i>Deluge System</i>
"Automatic" Sprinkler Corp. Of America	Pre-Action Sprinkler System	Deluge Sprinkler System
(For general description and application of these types of systems, see Section 13 of the Sprinkler Rules (Data Sheet 2-8) and the Approved Equipment Manual.)		

Pre-action sprinkler systems or deluge systems using a Model A automatic water control valve do not have any supervisory air pressure in the air tubing to the HADs or in the sprinkler system piping. It is not practical to provide supervisory air equipment for these systems.

Unsupervised automatic water control valves are not recommended for use with systems having over 20 sprinklers. Some installations of the Model A valves were made on larger systems. When these larger systems are found, recommend changing to a wet-pipe or dry-pipe system or, if the deluge or pre-action feature should be maintained, recommend replacement of the Model A valves with modern approved automatic water control valves and supervisory air equipment.

Repair parts are available for those Model A automatic water control valves still in service.

DESCRIPTION

Automatic Water Control Valve (Fig. 159 except noted)

The Model A automatic water control valve is a differential angle check valve having a differential of 2.5 to 1. The upper clapper (4) has a rubber facing (29) held in place by a bronze clamping ring (6) and seats on seat ring (21). The lower clapper (8), attached to the underside of the upper clapper (4) by a ball and socket connection (15), has a bronze facing (34) and seats on seat ring (20). These clappers (4 and 8) are pivoted about shaft (22) with weight (19) serving to almost counterbalance the clappers (4 and 8).

A restriction body (3) containing two separate restriction orifices is bolted to the side of the valve body (1). This restriction body (3) and one restriction orifice (W) form a connection between ports (B) and (C) above and below clappers (4) and (8), respectively. This connection automatically maintains system water pressure

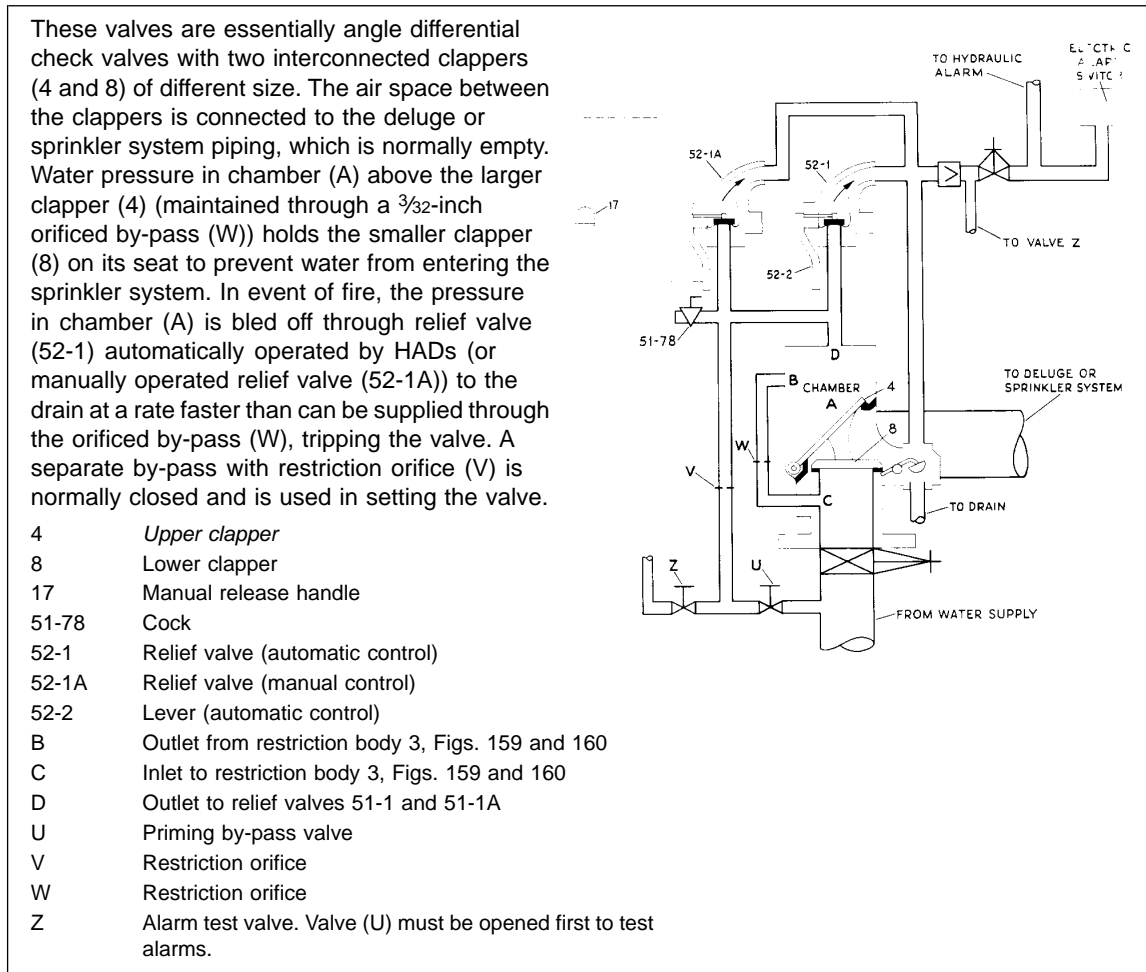

Fig. 158. Schematic drawing of Model A automatic water control valve and piping connections.

in chamber (A) on the upper side of clapper (4). A priming by-pass (controlled by manual gate valve (U) Figs. 1 and 3) from below the main manual water control valve is piped to restriction body (3). This by-pass permits system water pressure to enter chamber (A) through the restriction orifice (V) so that the automatic water control valve may be set.

Releasing Mechanism (Fig. 159)

The automatic releasing mechanism for the automatic water control valve is housed in a metal release box (51) bolted to the top of the valve body. The automatic releasing mechanism consists of a diaphragm and lever assembly (S-80-112A), weight (48) and relief valve assembly (52-1). The inlet of the relief valve is piped to the top of chamber (A) (at D) and the outlet to a drain connection at (Y).

The manual releasing mechanism for the automatic water control valve is housed in a metal release box (57) bolted to the side of release box (51). The manual releasing mechanism consists of a relief valve assembly (52-1A) similar to (52-1), a manual control cable, and rocker arm (59) to open the relief valve. The inlet of this relief valve is connected to the manually controlled by-pass between the restriction orifice (V) and chamber (A).

Actuating Mechanism (Figs. 159 and 160)

Automatic control of the release mechanism is by heat actuated devices (HADs) (87-530) which are pneumatic thermostats located so as to detect fires in the area protected. These thermostats operate on a predetermined rate of rise of temperature.

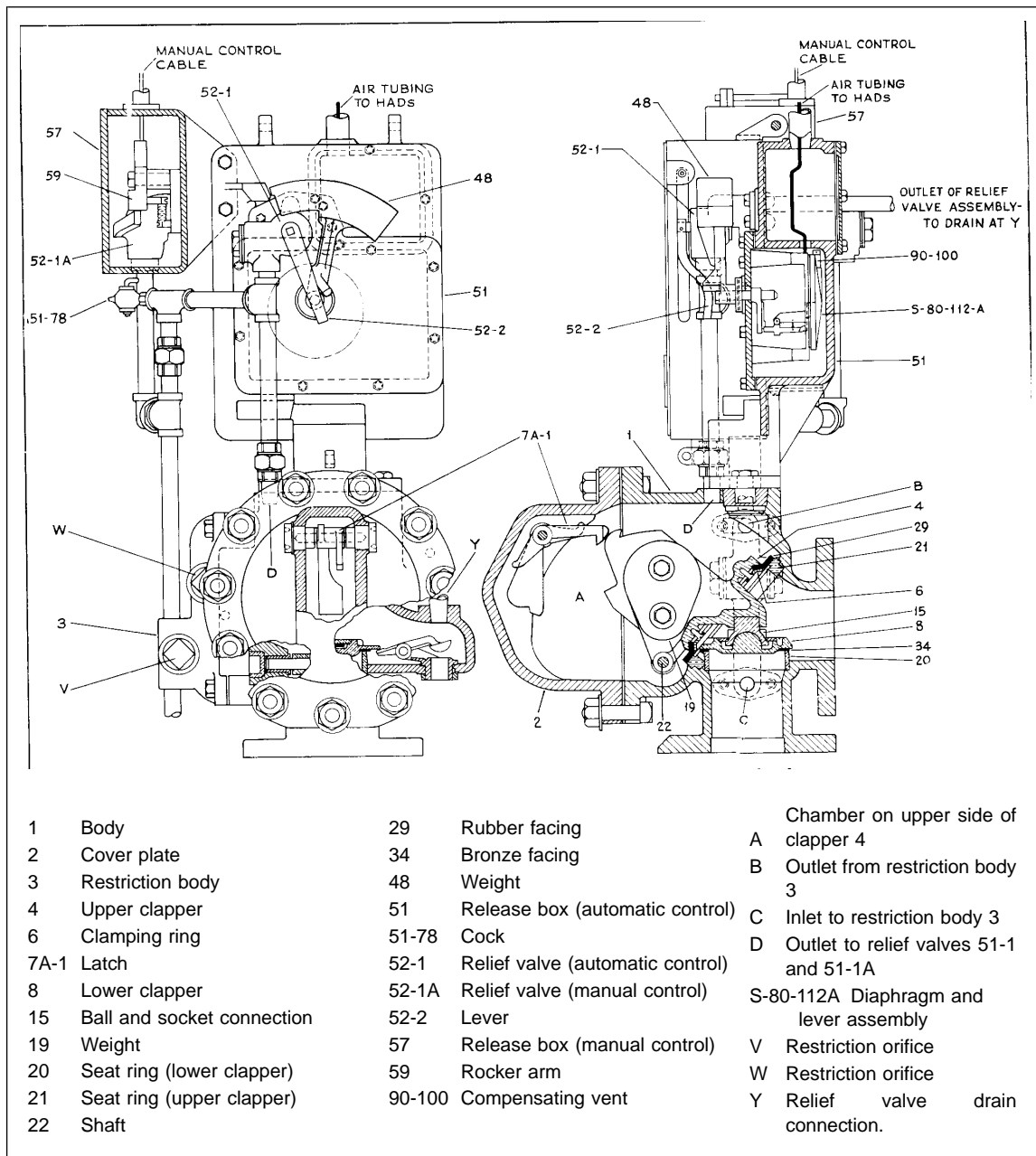

Fig. 159. Automatic water control valve Model A - details of valve.

The HADs (87-530) are hollow brass chambers. Heat from a fire is absorbed by the brass shell and is conducted to the air inside. The air expands creating a pressure impulse in the tubing causing movement of the diaphragm of assembly (S-80-112A) which, in turn, actuates the automatic release mechanism.

HAD's having a polyurethane enamel and epoxy coating are acceptable for use in the following corrosive environments:

<i>Acetic acid, 2%</i>	<i>Potassium hydroxide</i>
Hydrochloric acid	Acetone
Hydrochloric acid, 2%	Latex
Nitric acid, 10%	Motor oil, 10W
Tall oil fatty acid (Sylfat 94)	Phenol, 10%
All common alkalis and solvents	Aircraft hydraulic fluid
Bromine water	Sodium chloride, 25%
Chlorine water	Sodium hypochlorite, Cl. 10%
Cutting oil	Sodium hypochlorite, Cl. 6%
Formaldehyde, 20%	Household detergent
Gasoline, regular	Water, deionized
Gasoline, premium	Water, sea
Hydrogen sulfide (Gas)	Water, tap
Methyl isobutyl ketone	Methyl ethyl ketone

OPERATION (Figs. 159 and 160)

With either a pre-action sprinkler system or deluge sprinkler system, heat from a fire is absorbed by the HADs (87-530) causing an increase in air pressure in the air tubing to the diaphragm of assembly (S-80-112A). When this pressure increases at a greater rate than can be vented by the compensating vent (90-100) of assembly (S-80-112A), the diaphragm moves causing the levers to release weight (48). Weight (48) then revolves about its pivot point causing lever (52-2) to move and open relief valve (52-1). Water from chamber (A) is then discharged to the drain at a rate faster than it can be supplied through the restriction orifice (W). This reduces the pressure above clapper (4) permitting the system water pressure below clapper (8) to force open these clappers (4 and 8) and permit water to enter the sprinkler piping.

As clapper (4) opens, it is latched and held in the open position by latch (7A-1).

For manual operation of the automatic water control valve, a handle (17) on the manual control cable (Fig. 3) may be pulled which causes rocker arm (59) to pivot and the relief valve (52-1A) in release box (57) to open. When relief valve (52-1A) opens, the water pressure in chamber (A) will be reduced as the water passes through opening (D) and connecting piping to the inlet of relief valve (52-1A), through relief valve (52-1A) and on to drain through the piping connected to the discharge of relief valve (52-1A).

SETTING (Figs. 159 and 160)

1. Close the indicator post gate or OS&Y valve for the system.
2. Drain the system by opening drain valve (11).
3. When the system has drained completely, open the cover of release box (51) and raise weight (48) until it catches. Close relief valve (52-1) by moving lever (52-2) to the right. Close the cover of release box (51).
4. Unbolt and remove cover plate (2). Carefully clean clappers (4) and (8) and their seats. Place clapper (4) on its seat. (This causes clapper (8) to return to its seat.) Replace and bolt cover plate (2).
5. Open the priming valve (U) and allow time for the pressure in chamber (A) to become equal (through restricting orifice (V)) to the system water pressure. This pressure is indicated by the gage (X).
6. Open cock (51-78), completely vent all air, and then close the cock.
7. Close drain valve (11).
8. Open the indicator post gate or OS&Y valve for the system. Make drain test.
9. Close priming valve (U).
10. Seal in the open position the main manual water control valve and the OS&Y valve controlling the water flow alarms.
11. The system is now in service.

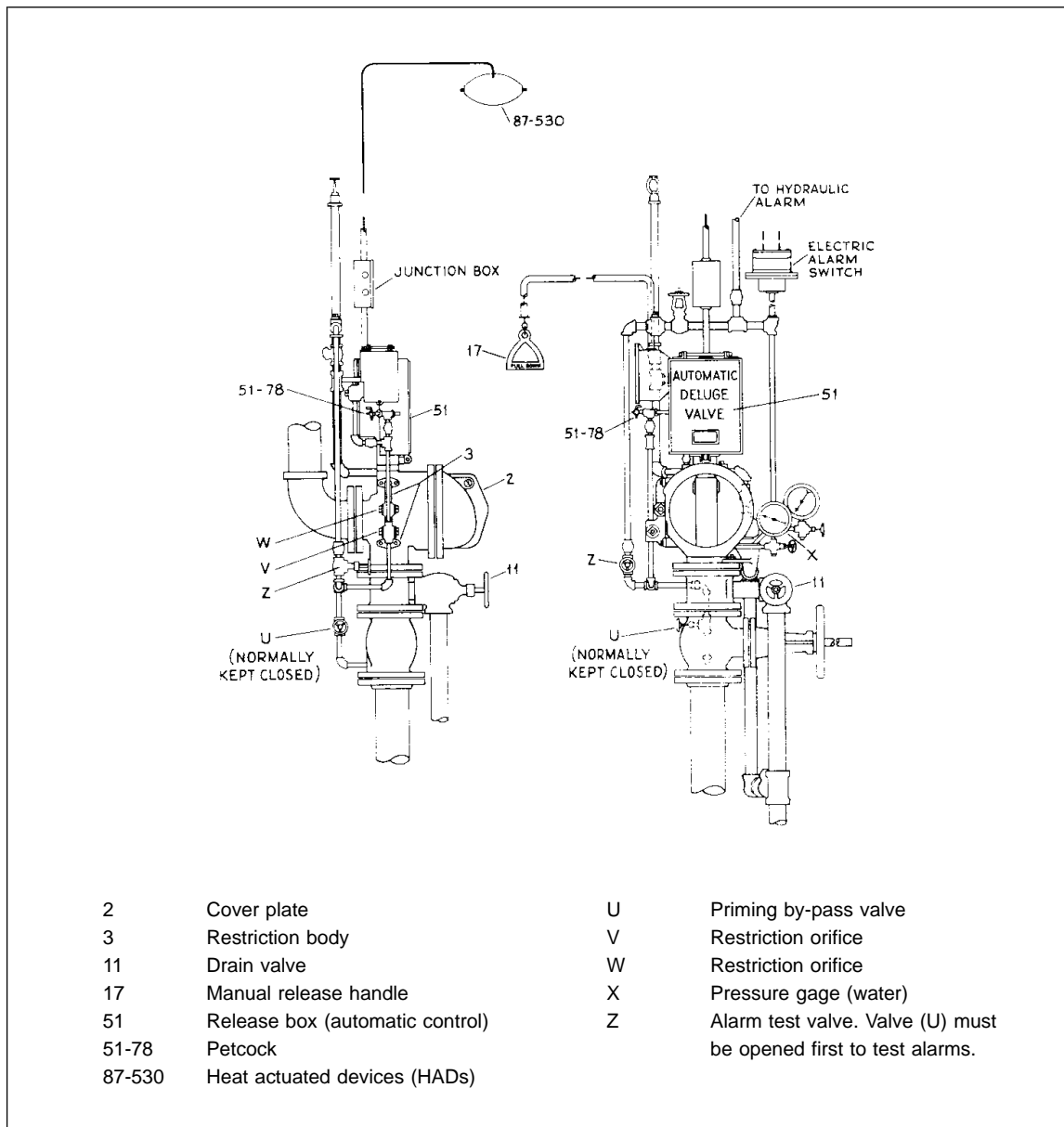

Fig. 160. Automatic water control valve Model A — piping arrangement at the valve.

MAINTENANCE AND INSPECTION

The manufacturer or installer of these systems usually provides a maintenance and inspection service under various contract forms. Unless the plant has specialized personnel who can adequately test and maintain these systems, it is advisable for them to purchase one of these maintenance and inspection contracts.

With these systems it is not usually practical for the plant mechanics to make anything other than minor adjustments and repairs. In order to avoid unnecessary damage to the systems, it is advised that unless the cause of trouble is readily apparent, the manufacturer or installer should be contacted to make necessary repairs and adjustments.

The water motor alarm and any electric alarms should be tested weekly. In order to test the alarms, both valves (U) and (Z) must be opened. If valve (Z) is opened without opening valve (U), the deluge valve may trip if restriction orifice (V) is larger than restriction orifice (W). All manual control valves should be inspected weekly to make sure that they are in the wide open position.

Procedure for Operational Tests (Tests should be made once a year.) (Figs. 159 and 160)

Note: The results of annual operational tests made under a sprinkler company inspection contract can be accepted in place of tests made by the Insured and witnessed by a Factory Mutual representative provided written evidence is furnished that the tests outlined below were followed in detail.

The impairment to protection resulting from operational tests should be kept to a minimum by following the procedure outlined. When making operational tests, be sure that any electric interlocks with fans, dump valves or conveyor equipment or other processes are taken care of to prevent undue interruption to plant operation.

When Water Cannot be Discharged from Deluge System

1. Close the main manual water control valve for the system and make sure valve (U) is closed. (Valve (U) should normally be kept closed.)
2. Apply the electric test set to the most remote HAD or test HAD if one is provided, noting the time required to actuate the relief valve (52-1). Operation should occur within one minute. If mercury checks are used to divide the HADs into groups, a similar test must be made on each group. Allow sufficient time between tests so that weight (48) can be reset. In areas where pyroxylin or other hazardous materials are stored or used in plant processes, immerse the HADs in a small container of hot water instead of using the electric heater.
3. Open the drain valve below the automatic water control valve to bleed off any pressure in chamber (A). Remove the cock (51-78) and replace it with a 3-way cock. Install an accurate test gage in one of the cock outlets. (To simplify the test procedure it is desirable to remove cock (51-78) and insert a shutoff valve having a 1/4-inch tee on its outlet. Cock (51-78) would be screwed into one outlet of the tee and a plug into the other outlet. The plug could be removed to install a test gage, and cock (51-78) could still be used to vent air.)
4. Close the drain valve below the automatic water control valve.
5. Move lever (52-2) so that relief valve (52-1) is closed.
6. Open valve (U) to build up pressure in chamber (A) above the clappers. Leave valve (U) open. Open the 3-way cock to bleed out any entrapped air and then set the cock so that the test gage will indicate the pressure in chamber (A).
7. Operate lever (52-2) manually to open the relief valve (52-1). Observe the pressure drop on the test gage and record the minimum pressure. This pressure should drop to zero. If the pressure does not drop to zero it indicates that the 3/8-inch pipe to or from relief valve (52-1) may be obstructed, relief valve (52-1) may be obstructed, or that restriction orifice (V) is too large.
8. Move lever (52-2) manually to close relief valve (52-1). The pressure indicated by the test gage should return to the original static pressure.
9. Pull handle (17) and note that the pressure drops to zero as in Step 7. If the pressure does not drop to this value, it indicates that the piping to or from relief valve (52-1A) may be obstructed, relief valve (52-1A) may be obstructed, or that restriction orifice (V) is too large.
10. Close valve (U) and open the drain below the automatic water control valve.
11. Remove the plugs on both sides of the restriction orifices (V) and (W). Inspect the orifice plates to see that they are in place and have the proper diameter (3/32-inch) hole. Replace the plugs.
12. Open the cover of release box (57) and close relief valve (52-1A) by moving the operating lever.
13. Remove test gage and 3-way cock. Replace cock (51-78).
14. Restore the system to service as described in Steps 3 through 11 described under SETTING.

When Water Can Be Discharged from Deluge System Without Causing Damage (Indoor or Outdoor) or When Automatic Control Valve is Connected to a Closed Head (Pre-Action) System (Fig. 160 except noted)

1. Open the drain valve (11) below the automatic water control valve.

2. Turn the manual water control valve for the system toward the closed position until the water pressure gage (X) indicates 5 psi. flowing pressure. In those outdoor locations where water can do no damage, the throttling of the water supply is not too important and advantage can be taken of the flow of water to determine that all sprinklers are open.
3. Close the drain valve (11) below the automatic water control valve.
4. Station a man at the manual water control valve and instruct him to close the manual water control valve and to open the drain valve when the automatic water control valve trips.
5. Apply the electric test set to the most remote HAD, or to the test HAD if one is provided, noting the time required to trip the automatic water control valve. Operation should occur within one minute. If mercury checks are used to divide the HADs into groups, it will be necessary to test the ability of each group after the first, to cause the weight (48, Fig. 159) to drop and actuate relief valve (52-1, Fig. 159). Allow sufficient time between tests so that the weight can be reset. It is not necessary to reset the automatic water control valve between the tests on the operation of the groups of HADs.
6. When the system has drained completely, remove the plugs on both sides of the restriction orifices (U) and (W). Inspect the orifice plates to see that they are in place and have the proper diameter (3/32-inch) hole. Replace the plugs.
7. Unbolt and remove the coverplate (2). Replace clappers (4 and 8, Fig. 159) on their seats. Replace the cover plate (2). Restore pressure in chamber (A) as described in Steps 5, 6, and 7 under SETTING.
8. Pull handle (17) and note that the pressure in chamber (A) drops to zero. If the pressure does not drop to zero, it indicates that the 3/8-inch pipe to or from relief valve (52-1A, Fig. 2) or, the relief valve itself, may be obstructed.
9. Restore the system to service as described in Steps 3 through 11 described under SETTING.

4.3 Automatic (ASCOA) Model C (Suprotex, Multitrol, Dualguard)

Deluge Systems and Preaction Sprinkler Systems

WITH "AUTOMATIC" WATER CONTROL VALVE MODEL C* 1 1/2 Inch — 1928 to Date

2 1/2 Inch — 1932 to Date

6 Inch — 1931 to Date

<i>Installer</i>	<i>Preaction System</i>	<i>Deluge System</i>
"Automatic" Sprinkler Corp. of America	Suprotex Sprinkler System	Suprotex Deluge System
Grinnell Corp.	Multitrol Sprinkler System	Multitrol Deluge System
Rockwood Sprinkler Co.	Dualguard Sprinkler System	Dualguard Deluge System

*All Model C valves used by the listed installers are manufactured by the "Automatic" Sprinkler Corp. of America. A different name plate is attached to cover 76-610 to identify the installer. For general description, application and installation see Sprinkler Rules and Approved Equipment manual.

DESCRIPTION

Automatic Water Control Valve (See Fig. 161)

The Model C automatic water control valve is essentially a single swing clapper check valve in which the rubber faced clapper (76-603) is held on its seat ring (76-635) by clapper latch (76-606A). The clapper latch (76-606A) is hinged to the body (76-601) and is bolted to a cast steel latch arm (76-612A) which forms a connection out through the body (76-601) to the weight guide rod (76-646).

Releasing Mechanism (See Fig. 161)

The releasing mechanism for the automatic control valve is housed in a two-compartment enclosing box (76-608B) and drip cup (76-609) which are bolted to the side of the body (76-601). One compartment of enclosing box (76-608B) is air tight and contains mercury checks (77-400) and their compensating vents (90-100), manual reset mechanism and the release box (80-1) which contains the automatic release assembly

(diaphragm, compensating vent, and lever system). The other compartment and drip cup (76-609) contain the 9 1/2-pound weight (76-611A), weight guide rod (76-646), latch arm (76-612A) and manual trip mechanism (62-135B, 76-624, and 76-631).

Cast onto the back of this latter compartment of enclosing box (76-608B) is a weight switch box containing a mercury weight switch (76-671A). This switch is used for interlocking the operation of the automatic water control valve with electric circuits supplying motors driving fire pumps, fans, conveyors, etc.

Prior to 1941 four individual mercury checks (77-400) having cast iron bodies were used. Since that time a suitably drilled stainless steel block combining all four checks has been used. The cast-iron-bodied mercury checks required a separate manifold (G) while with the stainless steel block the manifold is incorporated in the block.

The mercury checks have two chambers of unequal areas connected by a small orifice tube. The inlet chamber is connected to a single group of heat actuated devices (HADs) through copper tubing equipped, at the check, with a calibrated orifice compensating vent. The outlet chamber is connected to the manifold (G).

The mercury checks prevent the pressure from HADs over the fire from being dissipated to other groups of HADs away from the fire. They also resist small pressure changes due to normal temperature fluctuations so that these changes are taken care of by the compensating vents.

In preaction sprinkler systems, the manifold (G) is connected by copper tubing to one side of a double acting diaphragm having a calibrated orifice compensating vent (see Figs. 7 and 8). The other side of the diaphragm is vented to the release box (80-1). An exception to this is when the system has less than 20 sprinklers, in which case the sprinkler rules do not require supervisory air pressure and a single acting diaphragm is used. In deluge systems a single acting diaphragm is used. In either system, this diaphragm controls the releasing levers for weight (76-611A).

On the back of weight (76-611A) there is a pivoted bronze latch (76-614C) consisting of two arms at right angles to each other for holding weight (76-611A) in the set position. A small spring holds the latch in a vertical position and allows resetting of the latch. When weight (76-611A) is in the set position one arm of the latch (76-614C) engages lever cap (76-656B) of the automatic release mechanism that extends out of the airtight compartment of enclosing box (76-608B). The other arm rests against manual pull rod (76-631) which is a part of the manual release mechanism. On the side of weight (76-611A) there is a lug which, when weight (76-611A) is in the set position, engages a lever from weight switch (76-671A) and keeps this switch closed.

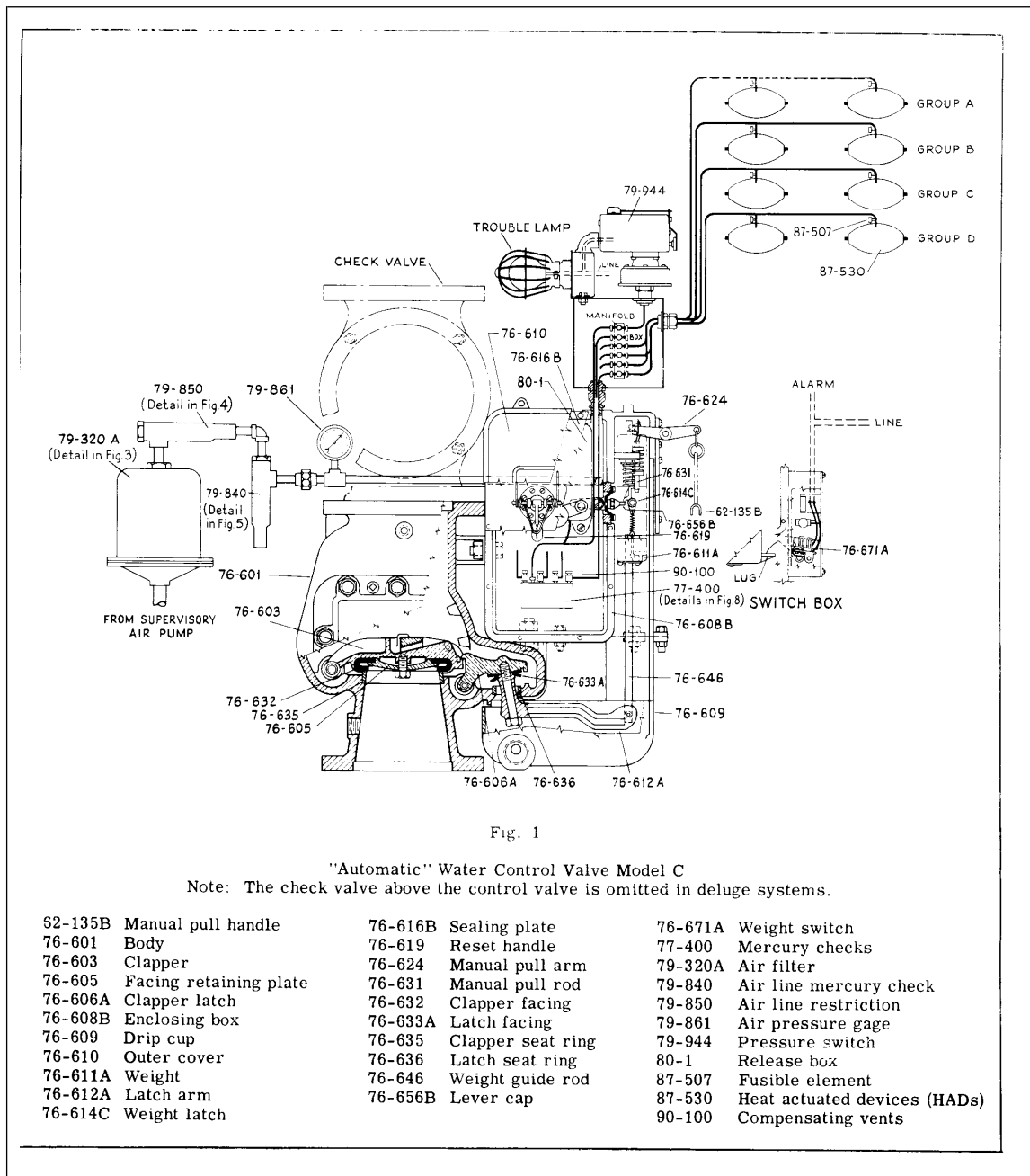

Fig. 161. "Automatic" Water Control Valve Model C
 Note: The check valve above the control valve is omitted in deluge systems.

Actuating Mechanism (See Fig. 161)

Automatic control of the release mechanism is by heat actuated devices (HADs) (87-530) which are pneumatic thermostats located so as to detect fires in the area protected. These thermostats operate on a rate of rise of temperature determined by the area of the orifice in the compensating vent (90-100) and the amount of mercury placed in the mercury check (77-400). The area of the orifices in the vents and the amount of mercury in the check valve are varied so that the automatic control valve will not trip because of normal temperature changes or any special operating temperature changes such as would occur when an oven is brought up to operating temperature.

A fusible element (87-507) is provided as a part of each HAD (87-530) for fixed temperature operation of the release mechanism.

HAD's having a polyurethane enamel and epoxy coating are acceptable for use in the following corrosive environments:

Acetic acid, 2%	Potassium Hydroxide
Hydrochloric acid, 20%	Acetone
Hydrochloric acid, 2%	Latex
Nitric acid, 10%	Motor oil, 10W
Tall oil fatty acid (Sylfat 94)	Phenol, 10%
All common alkalis and solvents	Aircraft hydraulic fluid
Bromine water	Sodium chloride, 25%
Chlorine water	Sodium hypochlorite, Cl. 10%
Cutting oil	Sodium hypochlorite, Cl. 6%
Formaldehyde, 20%	Household detergent
Gasoline, regular	Water, deionized
Gasoline, premium	Water, sea
Hydrogen sulfide (Gas)	Water, tap
Methyl isobutyl ketone	Methyl ethyl ketone

The HADs (87-530) are hollow brass chambers. Heat from a fire is absorbed by the brass shell and is conducted to the air inside. The air expands creating a pressure impulse in the tubing which passes through the mercury check (77-400) on the circuit to the diaphragm which operates the automatic release mechanism.

Manual control of the release mechanism is through manual pull arm (76-624) which lifts manual pull rod (76-631) when handle (62-135B) is pulled. When manual pull rod (76-631) moves upward, weight latch (76-614C) pivots and releases weight (76-611A).

Supervisory Air Supply Pump (See Fig. 162)

Supervisory air pressure at 1.5 psi is supplied by an automatically controlled pump. This pump may be either hydraulically or electrically operated. The hydraulically operated pump works on the ejector principle and takes its water supply from the supply side of the main manual control valve for the sprinkler system. In both the preaction and deluge systems supervisory air pressure is supplied to the HADs (87-530), connecting tubing, and automatic release mechanism. In the preaction sprinkler system supervisory air is also supplied to the sprinkler piping. An exception to this is when the sprinkler system has less than 20 sprinklers, in which case the sprinkler rules do not require supervisory air.

Since 1941, the hydraulically operated pump has been diaphragm-controlled. When the pressure in the air chamber (Fig. 162) drops to 1 psi due to leakage of air from the system, spring (120-136) forces diaphragm (120-145) inward causing pump valve lever (120-126) to open the pump valve (S120-101A). Water then enters the pump housing through pipe B, flows through the venturi jet and draws air from the atmosphere through check valve C into the air chamber of the pump. The water that has entered through the jet also falls into the air chamber and air leg and is forced into the water leg of the pump by the air pressure created in the air chamber. Any excess water is forced out through the overflow into a drain.

Air pressure is determined by the amount of water in the water leg as the air leg and water leg constitute a U-tube. As the air pressure in the air chamber changes, the height of water in the water leg will change accordingly.

In the event of a major rupture in the sprinkler piping or the thermopneumatic system, the supervisory air pressure escapes faster than the pump can supply it. In this case, the air pressure in the air chamber of the pump would continue to decrease until the pressure 0.5 psi is reached. At this point the diaphragm mechanism controlling the trouble alarm valve would move inward and cause the trouble alarm valve to open admitting water to the piping to the trouble alarm siren.

In some cases the diaphragm and other mechanism controlling the water to the trouble alarm is omitted and this alarm controlled through a pressure switch connected to an electric bell.

From 1931 to 1941 a hydraulically operated pump of different design controlled by a float instead of a diaphragm was used. This pump works on the same principle as the diaphragm type except that a float rides on the water in the air leg and controls the air pump valve and trouble alarm valve.

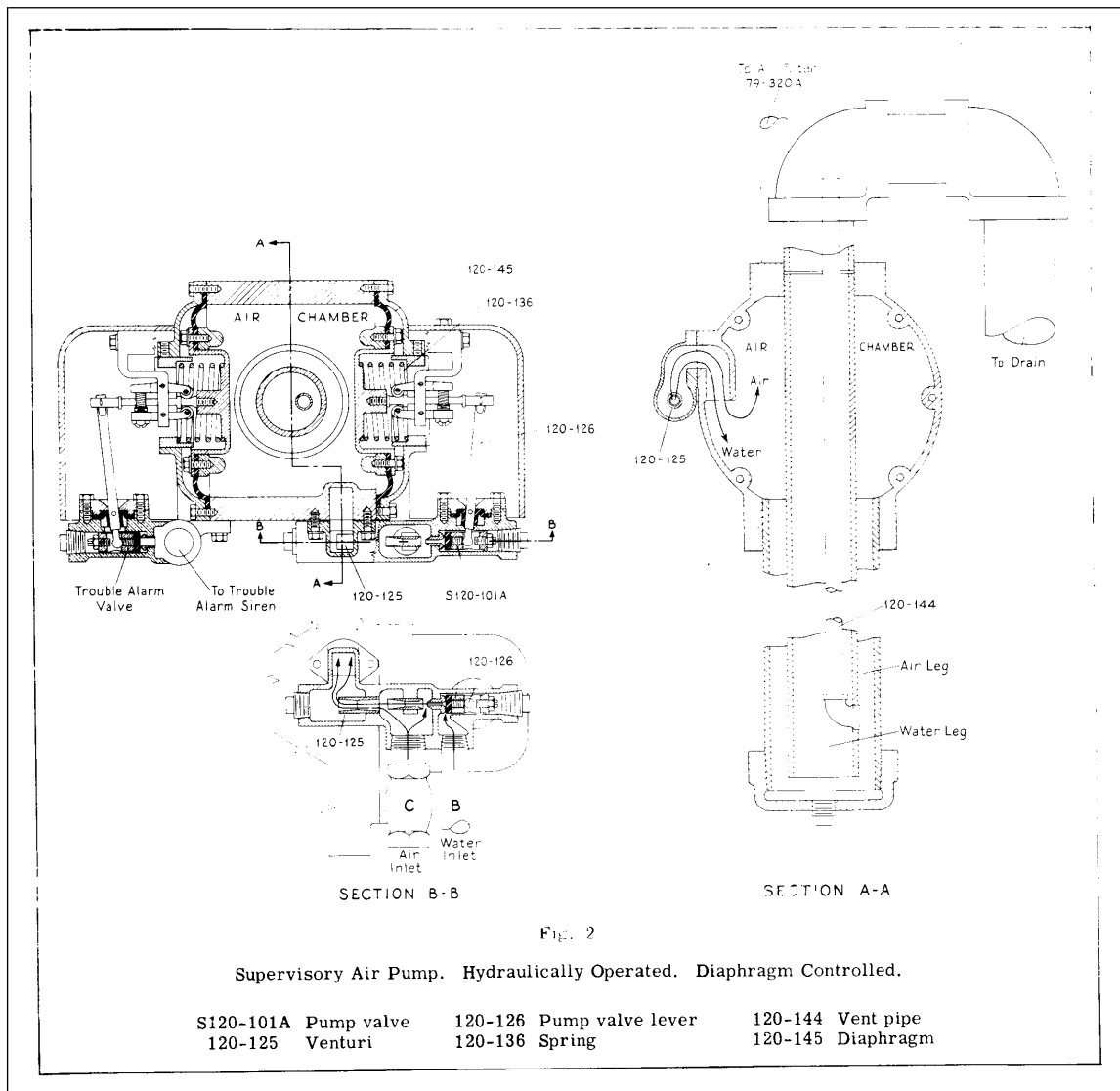

Fig. 162. Supervisory Air Pump. Hydraulically Operated. Diaphragm Controlled.

Since 1934 an electrically driven rotary pump equipped with two pressure switches (one to start the pump and one to actuate a trouble alarm) may have been supplied in place of a hydraulically operated pump.

AUXILIARY EQUIPMENT

Air Filter (Fig. 163)

An air filter (79-320A) is installed in the air line between the air pump and the release system to eliminate moisture from the supervisory air. This unit consists of a cast iron chamber bolted to a base. The chamber contains a 2½ -pound canister of activated alumina. Baffles are provided inside the canister to give maximum air contact.

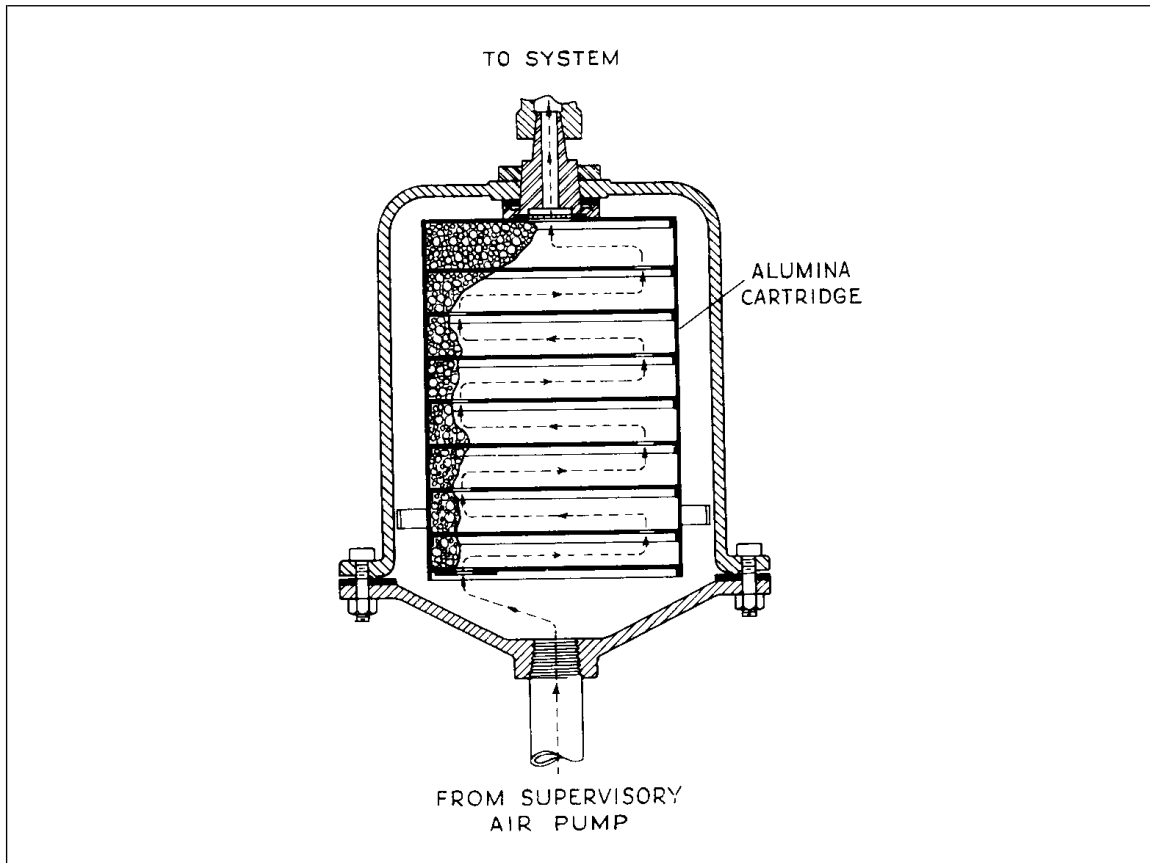

Fig. 163. Air Filter (79-320A).

Air Line Restriction (Fig. 164)

An air line restriction (79-850) is installed in the air line between the dehydrator and the release system to regulate the flow of supervisory air from the air pump to the release enclosing box at the same rate or slower rate than the compensating vents pass the air from the release enclosing box to the air tubing and HADs. This consists of a casting containing a calibrated orifice followed by a filter of kapok between two screens.

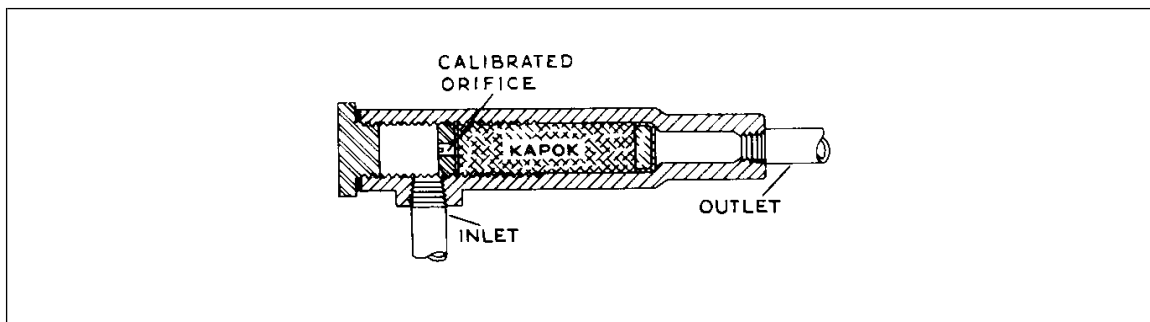

Fig. 164. Air Line Restriction (79-850).

Air Line Mercury Check (Fig. 165)

A mercury check (79-840) is installed in the air line between the air line restriction and the release system. This consists of a cylindrical casting with a well containing mercury at the bottom. The air inlet extends below the surface of the mercury. The outlet is connected above the mercury. The air pump forces the supervisory air through the mercury and the check action prevents the pressure leaking back to the pump.

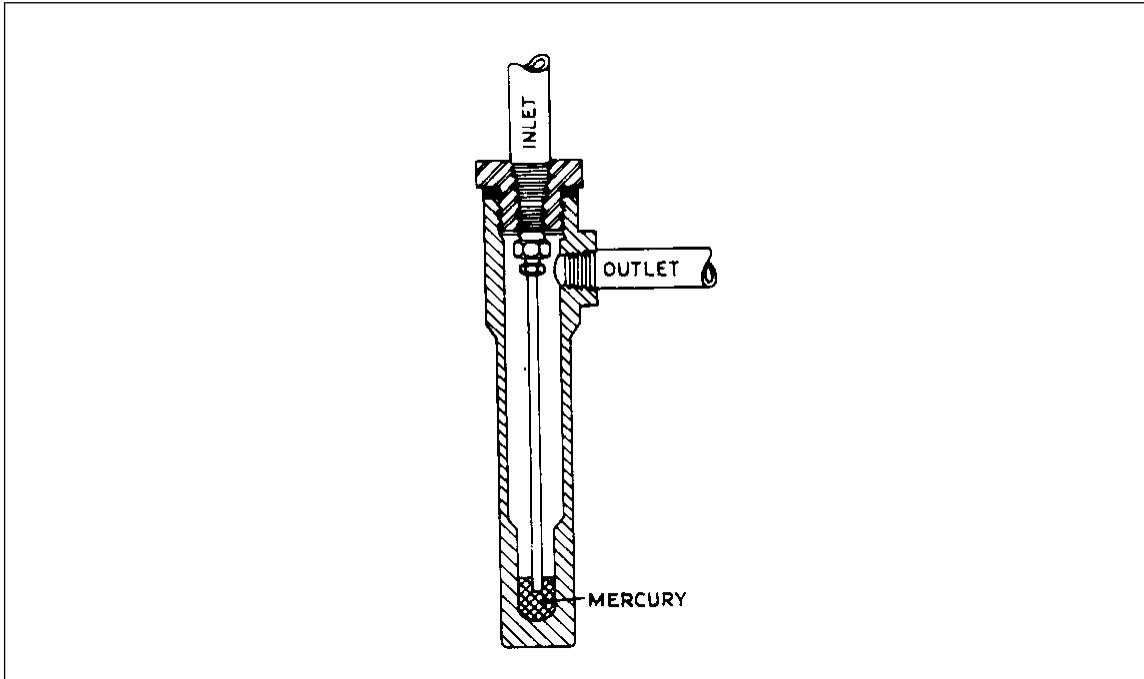

Fig. 165. Air Line Mercury Check (79-840).

Anti-Flooding Valve (Fig. 166)

When an electrically driven air pump is used in a preaction sprinkler system, an anti-flooding valve is installed in the air line from the pump to the sprinkler piping. This is a solenoid operated valve that closes and prevents water entering the air pump when the automatic water control valve trips.

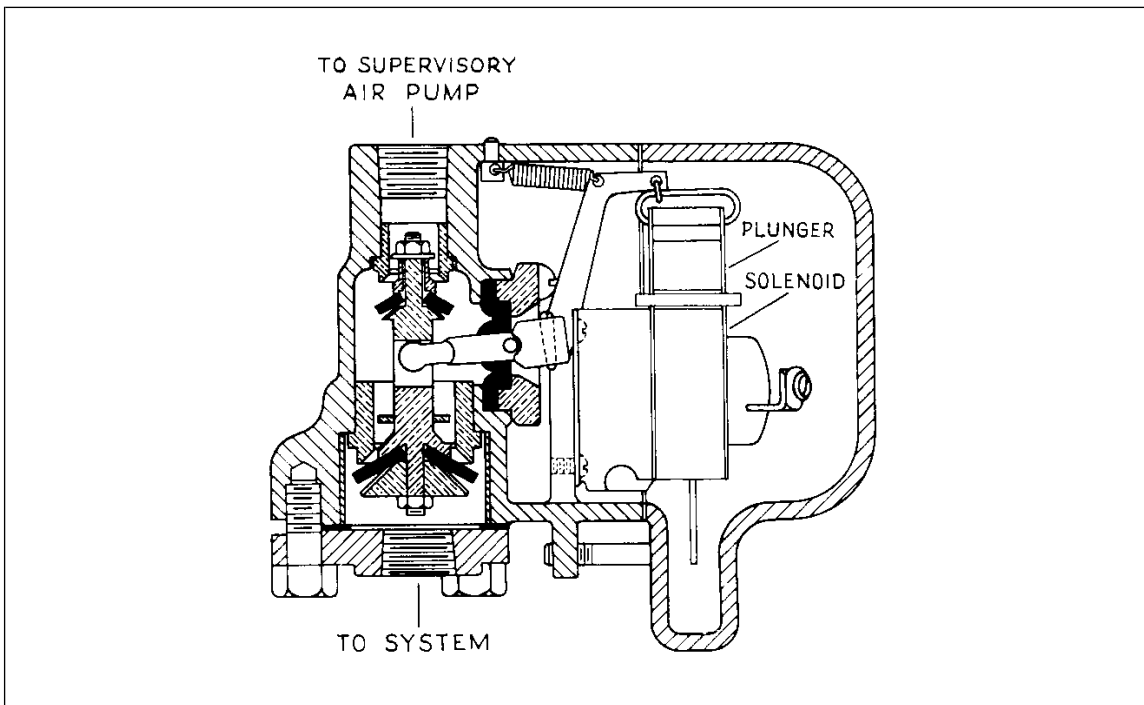

Fig. 166. Anti-Flooding Valve (105-100).

Monitor Switch or Valve

The gate valve controlling the system water supply, whether an indicator post and/or O.S. & Y. valve is equipped with a supervisory device (monitor switch or monitor valve) to sound the trouble alarm when the control valve is turned one or more turns from the open position toward closing.

A monitor switch mounted similarly to those used for central station valve supervision is usually used. Closing of the system control valve causes the monitor switch to close and energize an electrical alarm system.

A monitor valve, whose stem rests in a slot on the stem of an O.S. & Y. valve or between two cams on an indicator post gate valve, is used where electrical supplies are not readily available or are unreliable.

Closing of the control valve causes the stem of the monitor valve to be moved so that the monitor valve is opened and water admitted to the trouble siren to give an alarm. Where an O.S. & Y. valve is the only control valve, it is tapped on the supply side to provide water to the monitor valve. Where an indicator post gate valve or a combination of indicator post gate and O.S. & Y. control valve is used, the water supply for the monitor valve is taken from a tap on the supply side of the indicator post gate valve.

OPERATION (Figs. 161 and 177 or 168)**When Fire Occurs**

With either a preaction sprinkler system or deluge system, heat from a fire acts upon the HADs (87-530) causing an increase in air pressure in the tubing to the inlet side of the mercury check (77-400) for that group of HADs. When this pressure increases at a greater rate than can be vented through the compensating vent (90-100) on the mercury check, air passes through the mercury and manifold (G) to one side of the diaphragm in the release box (80-1). The increase in pressure in the manifold (G) is prevented from dissipating into other groups of HADs by the check action of the other mercury checks. When the air passing through the mercury causes the pressure of one side of the diaphragm to increase at a greater rate than can be discharged through the compensating vent (N, Fig. 167 or 168) at the diaphragm, the diaphragm will move. Movement of the diaphragm allows lever (76-656B) to pivot, permitting latch (76-614C) to pivot and drop weight (76-611A). Weight (76-611A) then slides down weight guide rod (76-646) to open the clapper latch (76-606A) permitting clapper (76-603) to open. The movement of the clapper latch (76-606A) forms a watertight seal between the rubber latch facing (76-633A) and the seat ring (76-636). When the clapper (76-603) opens, water flows into the sprinkler piping and to the water motor alarm.

When Supervisory Air Leaks from Air Tubing

With a preaction sprinkler system, if leakage of supervisory air from the air tubing occurs at a rate *faster* than air from the airtight compartment of enclosing box (76-608B) can be supplied through the compensating vent (90-100) at the mercury check, pressure in inlet chamber of the mercury check is reduced. The higher pressure in manifold (G) then forces air through the mercury and out to the air tubing. The supervisory pressure in manifold (G) is thus lowered faster than it can be replenished from the release box (80-1) through the compensating vent (N, Fig. 7 or 8) on the diaphragm. This reduces the pressure on one side of the diaphragm causing it to move and trip the valve in the same manner as when a fire occurs. Thus, the valve fails safe and the system then acts as a wet pipe system.

If leakage of supervisory air from the air tubing occurs at a rate *slower* than air from the airtight compartment of enclosing box (76-608B) can be supplied through the compensating vent (90-100) at the mercury check, the pressure in the inlet chamber of the mercury check will not be reduced. When the pressure in the airtight compartment of enclosing box (76-608B) reaches 1 psi, the air pump will start and replenish the lost pressure. Should the air pump fail, the supervisory air will continue to leak out with further reduction in pressure. When the pressure reaches 0.5 psi, the trouble alarm will sound. With this type of slow leak, the automatic water control valve will not trip.

With a deluge system the only difference is that the lowering of pressure in manifold (G) by a large leak in the air tubing does not cause the water control valve to trip since the diaphragm can move in only one direction. In deluge systems the manifold is connected to the pressure switch and a trouble alarm and signal light. When the pressure in manifold (G) is reduced because of leakage in the air tubing, the pressure switch (79-944) operates, completing the circuit to the trouble alarm and signal light.

A very rapid leak in the air tubing can blow mercury out of a mercury check and carry it through the connecting tubing to some other location. This can occur with supervisory air pressures as low as 18 oz./sq. in. If the

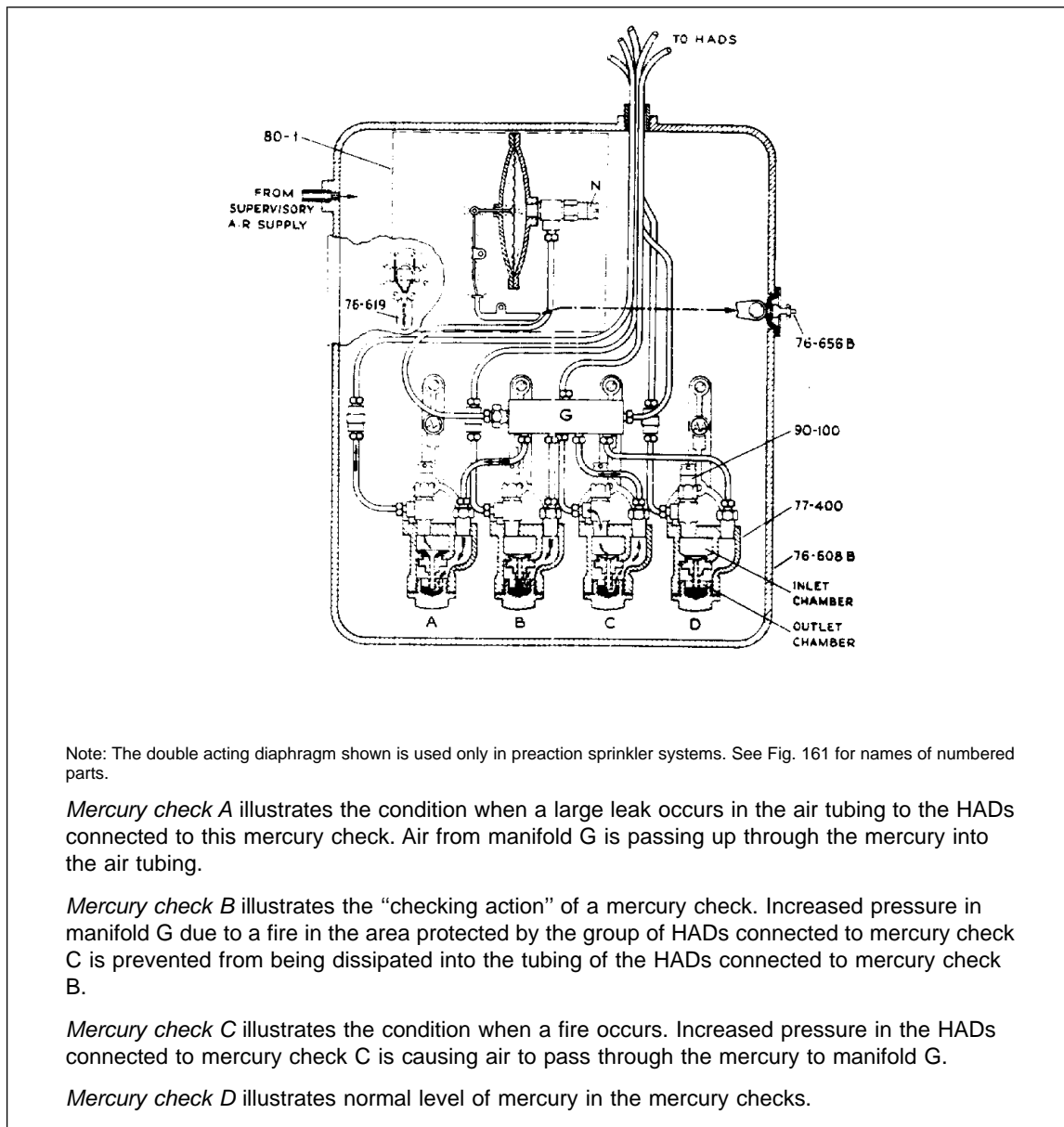

Fig. 167. Action of Mercury Checks Supplied Prior to 1941 (Diagrammatic).

copper tubing connecting the HAD's has been physically damaged sufficiently to result in a rapid loss in air pressure, examine the mercury check setting of that particular system to ensure that no significant amount of mercury was moved.

Leakage of Supervisory Air From Sprinkler Piping

With a preaction sprinkler system the leakage of supervisory air from the sprinkler piping causes the automatically controlled pump to start when the pressure has been reduced to 1 psi. If the leak is such that the pump can supply the air and raise the pressure to the normal 1.5 psi the pump will shut off. If the leak is beyond the capacity of the pump or if the pump fails, the pressure device on the pump will cause the trouble alarm to sound should the pressure in the sprinkler piping be reduced to 0.5 psi.

The automatic water control valve will not be tripped by loss of supervisory air from the sprinkler piping. By this arrangement, an accidental pipe break in a preaction sprinkler system will not cause “sprinkler leakage” damage.

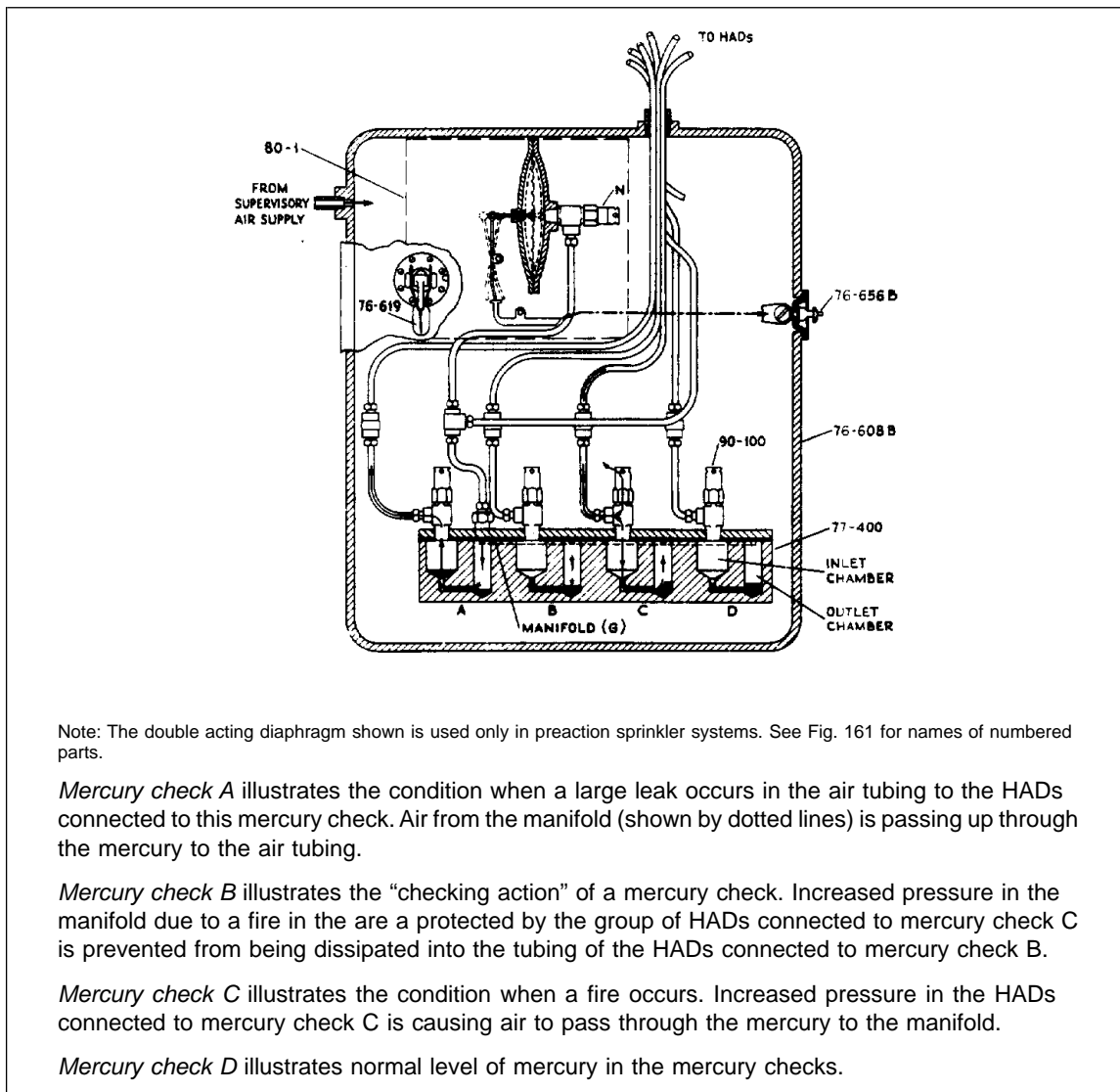

Fig. 168. Action of Mercury Checks Supplied After 1941 (Diagrammatic).

SETTING (See Fig. 161)

1. Close the indicator post gate or O.S. & Y. valve for the system.
2. Either close the stop-cock controlling the water to the hydraulic air pump or shut off the electric air pump.
3. Close the valves in the pipes to the water siren (trouble alarm) and water motor gong.
4. Open the drain valve below the automatic water control valve. In a preaction sprinkler system also open the drain valve above the check valve.
5. Remove the cover from the automatic water control valve and clean the seat and rubber facing. In a preaction sprinkler system also remove the cover from the check valve above the automatic water control valve and clean the seat and rubber facing.
6. Place the clapper of the automatic control valve on its seat and replace the cover.
7. In a preaction system also place the clapper of the check valve on its seat, replace its cover and pour priming water through the priming cup.

8. Remove the outer cover (76-610) from the enclosing box (76-608B) housing the release mechanism. **Do Not Remove the Gasketed Sealing Plate** (76-616B).
9. Simultaneously pull the reset lever (76-619) outward and raise the weight (76-611A) until the latch (76-614C) on the side engages lever (76-656B). This operation automatically latches the water clapper shut. Release the reset lever (76-619).
10. Close the drain valve(s).
11. Open the stop-cock to supply water to the hydraulic air pump or turn on the electric air pump.
12. When the air pump stops operating, open the indicator post gate or O.S. & Y. valve for the system slowly until the lever on the monitor valve or switch fits into the groove on the stem at the wide open position.
13. Open the valves in the pipes to the water motor gong and trouble siren.
14. Test the drain valve below the automatic water control valve. Then seal in the open position all manual water control valves that have been operated.
15. The system is now in service.

MAINTENANCE AND INSPECTION

The manufacturer or installer of these systems offers a maintenance and inspection service under various contract forms. Unless the plant has specialized personnel who can adequately test and maintain these systems, it is advisable for them to purchase one of these maintenance and inspection contracts. With these systems it is not usually practical for the plant mechanics to make anything other than minor adjustments and repairs. In order to avoid unnecessary damage to the systems, it is advised that unless the cause of trouble is readily apparent, the manufacturer or installer be contacted to make necessary repairs and adjustments.

The water motor alarm and trouble siren should be tested weekly. All manual control valves should be inspected weekly to make sure that they are in the wide open position.

The automatic water control valve should be triptested annually.

If any part of the thermopneumatic system is exposed to freezing temperature, check the weight of alumina in the dehydrator annually. Where the thermopneumatic system is not exposed to freezing temperatures, the weight of the alumina should be checked every three years. Should the weight of the canister exceed 3 pounds, replace the alumina or dry it out in an oven.

Procedure for Checking Supervisory Air (Test should be made at each FM Global inspection)

Note: The results of a test for checking supervisory air made under a sprinkler company inspection contract can be accepted in place of a test made by the Insured and witnessed by a FM Global representative. Frequency of tests by either one or the other should be not less than the frequency of Factory Mutual inspections.

1. Close the indicator post gate or O.S. & Y. valve controlling water to the system.
2. Open the 2-inch drain below the automatic water control valve.
3. Open the cabinet containing the header for the air tubing (shown in Fig. 161 beneath the trouble lamp).
4. (a) In a preaction sprinkler system, loosen the plug on the header in the air line marked "manifold". There will be one of these plugs for each airtight cabinet containing mercury checks. Any one of these "manifold" plugs may be loosened for this test. As the plug is loosened and air escapes, note that the air pump starts. As soon as the air pump has started, immediately tighten the plug to prevent excessive loss of air and the tripping of the automatic water control valve.

(b) With a deluge system, proceed as for a preaction sprinkler system except that the plug should remain loosened until the trouble siren sounds. As soon as the trouble siren has sounded, tighten the plug.
5. Close the 2-inch drain valve and open the indicator post gate or O.S. & Y. water control valve for the system. Seal control valve in the open position.

Procedure for Operational Tests (Tests should be made once a year).

Note: The results of annual operational tests made under a sprinkler company inspection contract can be accepted in place of tests made by the Insured and witnessed by a FM Global representative.

1. In a preaction sprinkler system release the supervisory air in the sprinkler piping by means of the inspector's test connection at the end of the system and note that the air pump starts and the trouble siren sounds. Close the inspector's test connection as soon as the trouble siren sounds to avoid excessive loss of air.
2. Close the indicator post gate or O.S. & Y. valve controlling water to the system.
3. Open the 2-inch drain below the automatic water control valve.
4. With either a preaction sprinkler system or deluge system, apply the electric test set to one of the HADs in each group, noting the time required to trip the automatic release. Operation should occur within one minute. Reset the release weight as described under Step 9 of SETTING between the test on each group of HADs and after the final test. In areas where pyroxylin or other hazardous materials are stored or used in plant processes, immerse the HADs in a small container of hot water instead of using the electric heater.
5. Wait about fifteen minutes to allow pressure in the thermopneumatic system to return to normal.
6. Remove a fusible plug from one HAD in each group. In a preaction sprinkler system this will cause the automatic release of the automatic water control valve to trip. In a deluge system it will cause the trouble siren to sound.
7. The fusible elements should be carefully replaced and the joints tested with a soap solution to make sure that they are tight.
8. Operate the release mechanism manually by pulling the hand mechanism.
9. Examine the automatic water control valve internally and clean the clapper and seat. In a preaction sprinkler system the check valve should be examined and cleaned internally also.
10. Return the system to service as described under SETTING.

4.4 Central Model AD

Deluge Systems

WITH CENTRAL WATER-CONTROL VALVE MODEL AD

3-Inch - 1958

4-Inch - 1958

6-Inch - 1958

The Model AD automatic water-control valve (Fig. 169) is essentially a single-swing clapper check valve in which the metal-faced clapper A is held on its rubber water-seat ring D by trip lever B. Bronze seat ring E to which the rubber seat ring is attached has an annular groove in its face and a series of small openings into the groove from the waterway. Water pressure forces the rubber seat ring into recessed grooves in the valve clapper to insure a leakless joint. The trip-lever is hinged to the valve body (1) and is held in position by bearing rod C whose thrust is absorbed by the ball joint K₁ in release cabinet (2).

The clapper is prevented from returning to its seat after the valve trips by latch F which engages a lug on the side of the clapper.

A 3/4-in. opening J provides for connection of an automatic drip valve and a mechanical or electric waterflow alarm. Opening H is a 2-in. drain outlet.

Releasing Mechanism

Release cabinet (2) is bolted to the side of valve body (1) and contains two solenoids connected in parallel. The solenoid plungers R are mechanically linked to vertical lever L by means of pin T. The vertical lever is hinged at post Z. Roller M is pinned to the vertical lever and rides on cam lever K. The cam lever K and bearing rod C are fastened rigidly together at ball joint K₁ which acts as a pivot.

Upon movement of the plungers to the left when the solenoids are actuated, vertical lever L moves and causes the roller M to push down cam lever K. This lifts the bearing rod C on the opposite side of ball joint K₁, releasing the trip lever B. Movement of the vertical lever and the cam lever is restricted by the engagement of locking plunger N in a recess in the cam lever. Movement of the vertical lever to the left also moves roller Q of the cutout switch, deenergizing the solenoids after the valve has operated.

Manual tripping of the valves is accomplished by an outward pull on knob and chain S.

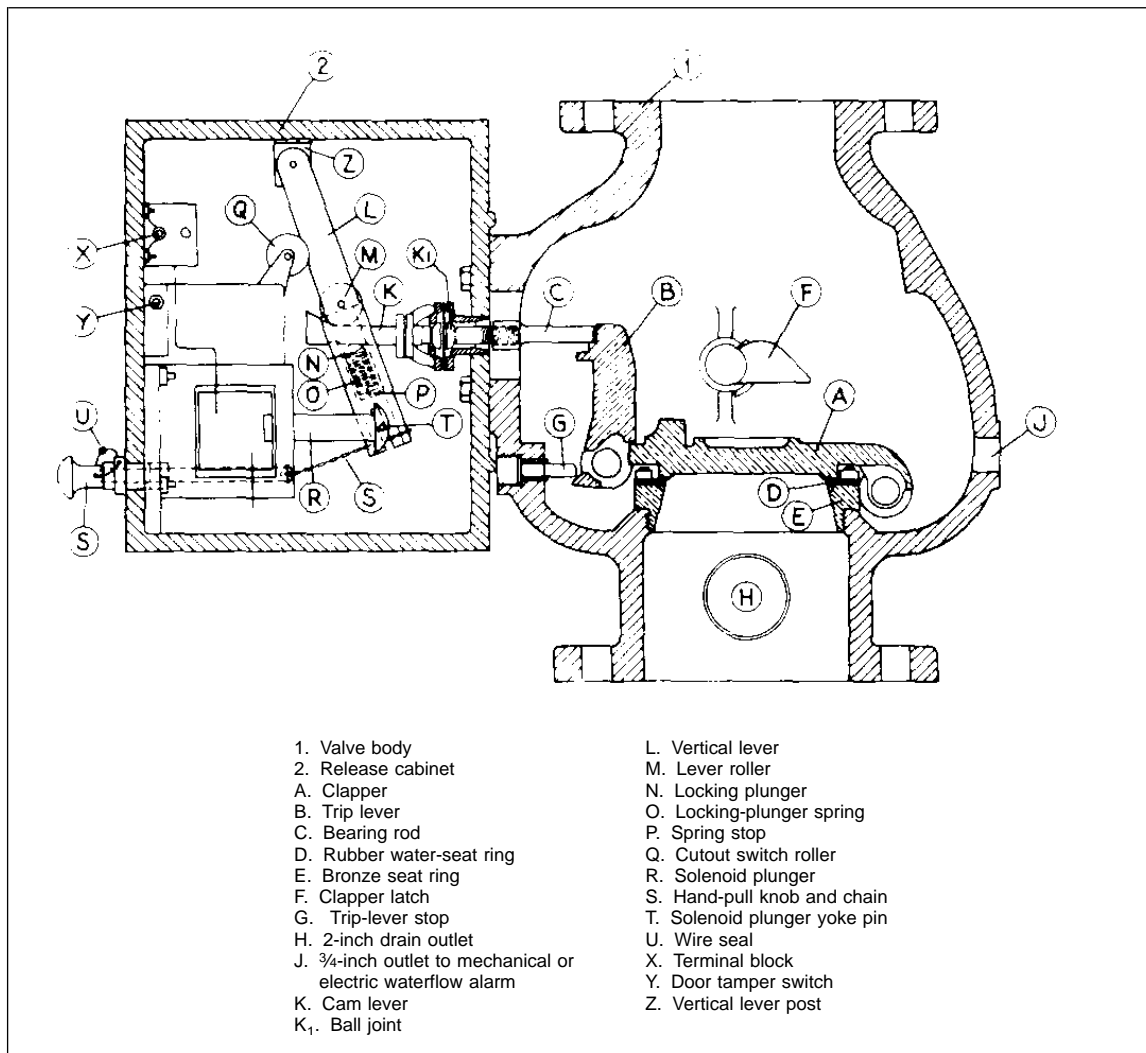

- | | |
|--|------------------------------|
| 1. Valve body | L. Vertical lever |
| 2. Release cabinet | M. Lever roller |
| A. Clapper | N. Locking plunger |
| B. Trip lever | O. Locking-plunger spring |
| C. Bearing rod | P. Spring stop |
| D. Rubber water-seat ring | Q. Cutout switch roller |
| E. Bronze seat ring | R. Solenoid plunger |
| F. Clapper latch | S. Hand-pull knob and chain |
| G. Trip-lever stop | T. Solenoid plunger yoke pin |
| H. 2-inch drain outlet | U. Wire seal |
| J. 3/4-inch outlet to mechanical or electric waterflow alarm | X. Terminal block |
| K. Cam lever | Y. Door tamper switch |
| K ₁ . Ball joint | Z. Vertical lever post |

Fig. 169. Central Model AD Water-control Valve & Release Cabinet.

Actuating Mechanism

Automatic control of the release mechanism is accomplished by fire-detection thermostats located where they will detect fire in the protected areas. These thermostats are a rate-of-rise and fixed-temperature type approved for this service.

Control Unit

The Central Model AD control unit (Fig. 170) is enclosed in a metal cabinet normally located above the release cabinet. Four relays, two terminal blocks and a door tamper switch are mounted inside. The control unit pilot light and McCulloh circuit switch and red pilot light are mounted in the door. The four relays are solenoid control relay CR-1, release supervisory relays CR-3 and CR-4, and general supervisory relay CR-2.

The McCulloh circuit switch and red pilot light are for use in event of a break in the fire-detecting circuit, until repairs are made. If a break occurs, a trouble bell sounds and the pilot light goes out. Manual throwing of the switch to the down position changes the normally closed circuit detector system into two open circuit systems.

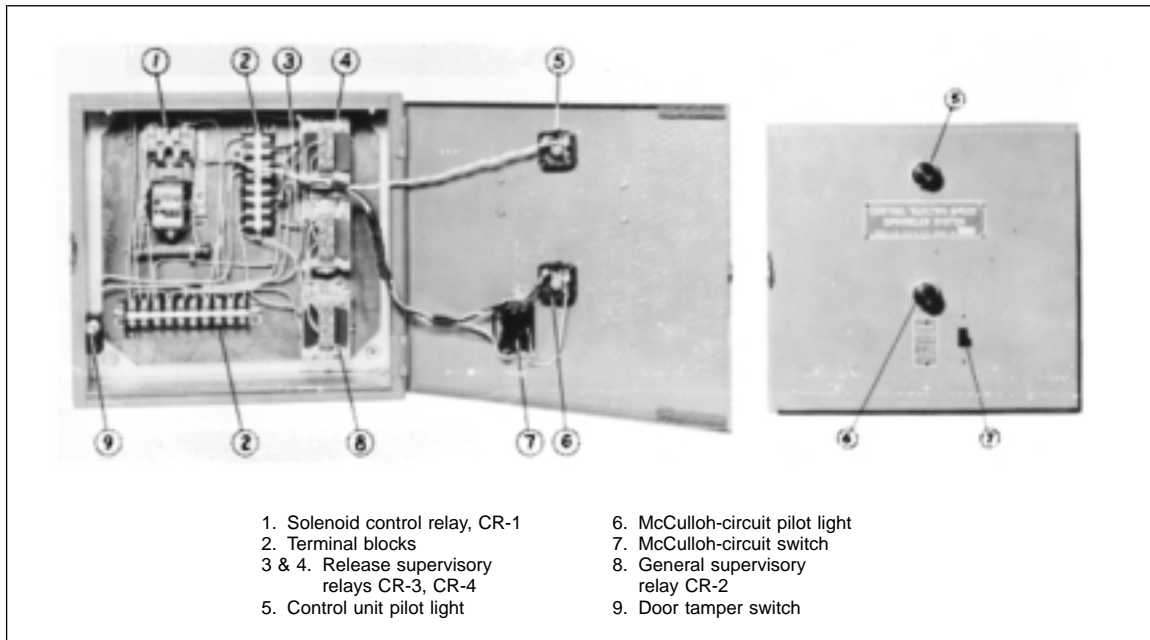

Fig. 170. Control unit.

Power Unit

The Central auxiliary power supply unit (Fig. 171) is enclosed in a metal cabinet. The unit includes electrical components to distribute two independent sources of electrical power so that either source will automatically operate the system if the other source fails. The normal power source is a reliable 110- to 115-volt a-c line. The emergency source is a 36-volt storage battery.

In the event of a-c power failure, a transfer switch automatically changes the load to the batteries and at the same time energizes the power failure gong.

Batteries

The emergency power source consists of a 3-cell 36-volt storage battery rated for 30 ampere-hours at an 8-hour rate. Specific gravity at full charge is 1.200-1.220 and each battery is equipped with pilot balls to indicate its condition. Batteries should be protected from mechanical damage. Leads should be short and a permanent type.

OPERATION

When Fire Occurs

The closing of the normally open contacts of a fire-detection thermostat shunts the system current through the solenoids and pulls solenoid plungers R (Fig. 169) into the magnetic field. Thermostat operation increases the current through relay CR-1 (Fig. 172) closing its contacts which in turn shunt out relays CR-3 and CR-4 and increase the current through the solenoids. Movement of the plungers to the left operates the release mechanism, freeing trip lever B (Fig. 169) and removing the restraining force. Water pressure on the clapper forces it upward, causing the trip lever to move and release the clapper, allowing water to enter the deluge piping.

Movement of the vertical lever opens the limit switch and deenergizes relay CR-1. This cuts off current to the solenoids and completely deenergizes the control panel pilot light and relay CR-2, completing the circuit to the trouble signal. When the deluge valve is reset, the limit switch automatically closes to energize relay CR-2 silencing the trouble bell.

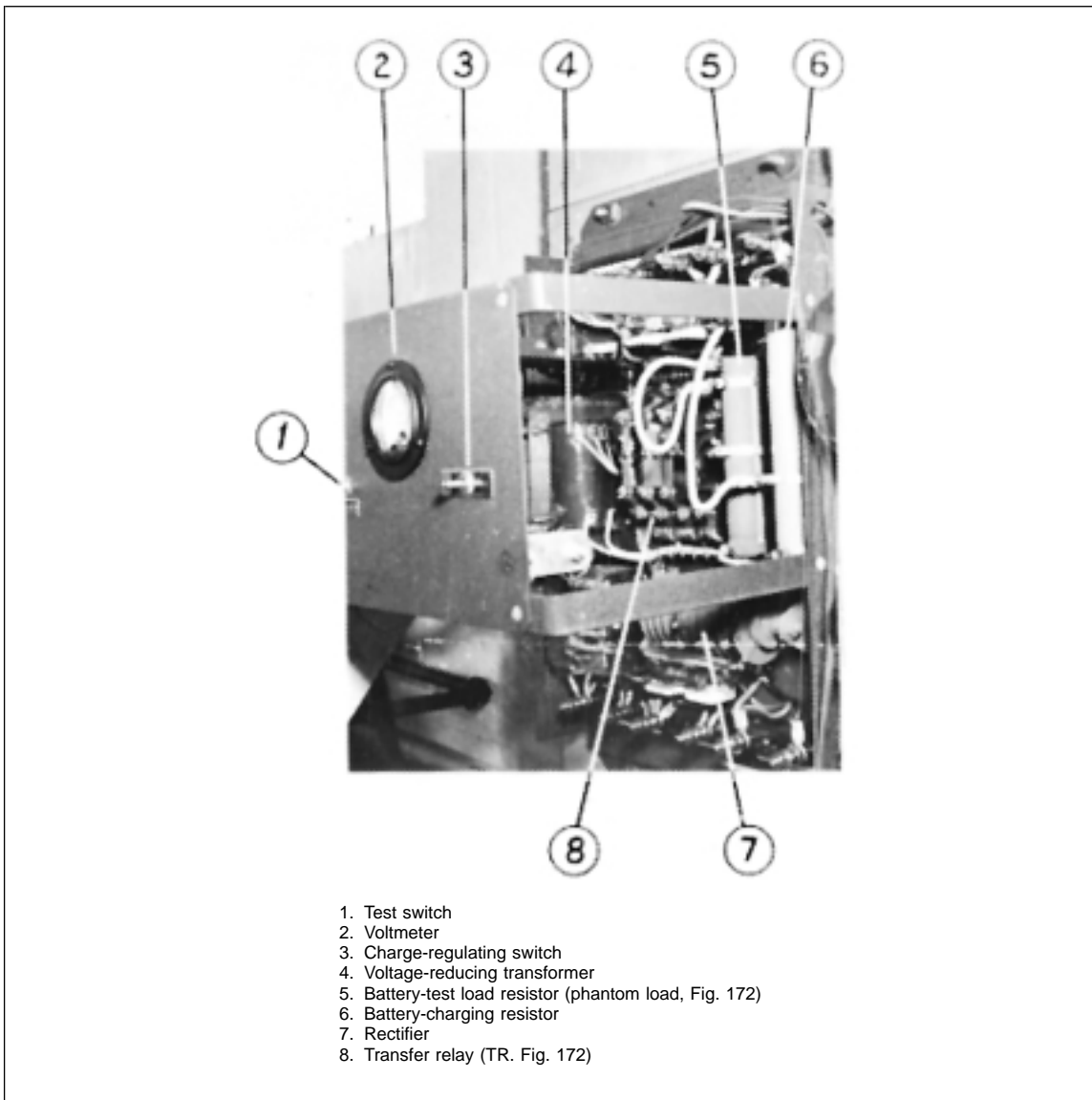

1. Test switch
2. Voltmeter
3. Charge-regulating switch
4. Voltage-reducing transformer
5. Battery-test load resistor (phantom load, Fig. 172)
6. Battery-charging resistor
7. Rectifier
8. Transfer relay (TR. Fig. 172)

Fig. 171. Power unit.

When Normal Power Supply Fails

When the a-c voltage fails, the coil of transfer relay TR is deenergized and reverses its contacts. This completes the circuit to the power failure gong and connects the battery to provide power for the supervisory circuit and for tripping the valve. The power failure bell continues to ring until normal a-c power is restored.

A break in the general wiring between the power supply unit and control unit does not give an audible trouble signal or permit automatic operation of the deluge system. Wiring should therefore be installed according to good electrical practices in metal conduit.

When Break Occurs in Supervisory Circuit to Thermostats

In event of a single break in the looped wiring to the thermostats, the red pilot light on the McCulloh circuit switch goes out and relay CR-2 is deenergized, closing its contacts to complete the circuit to the trouble bell. The bell continues to ring until the break is repaired or until the manual double-throw McCulloh circuit switch is moved to the down position. Operation of this switch energizes relay CR-2 to silence the trouble signal and energizes the red pilot light adjacent to the switch. It also transfers the closed circuit detector

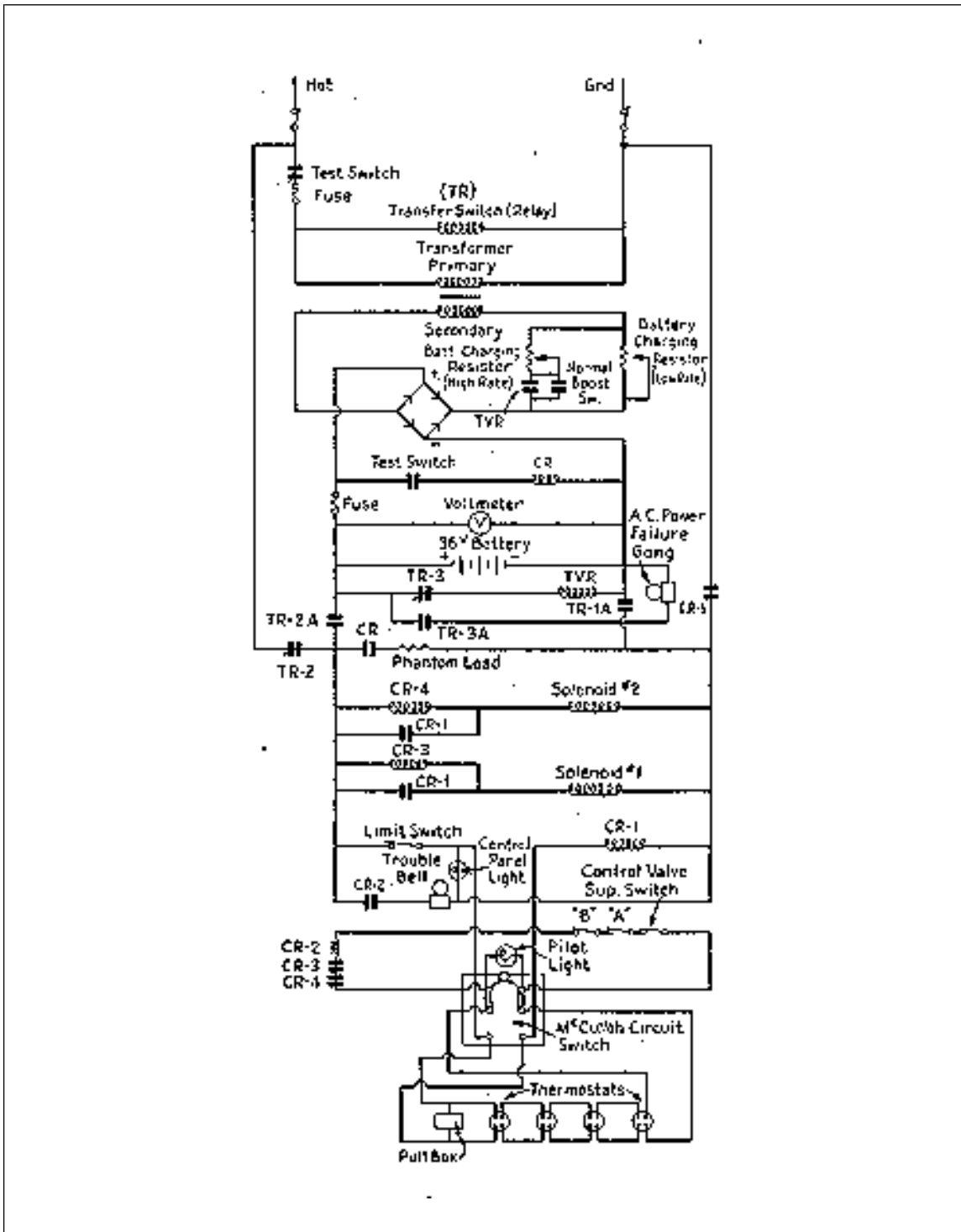

Fig. 172. Electrical circuit for Central Model AD water-control valve. Relay contacts shown in energized position.

system into two open systems each operative to the point where the break exists. When repairs are completed, the McCulloh circuit switch is returned to its normal position causing the pilot light to go on.

When Break Occurs in Solenoid Release Circuit

In event of a break in the solenoid release circuit, either relay CR-3 or CR-4 will be deenergized and contacts will open. This deenergizes relay CR-2 which in turn closes its contacts to complete the circuit for the trouble bell.

Tamper Safeguards

Closing the main manual water-control valve, or opening the door on either the control panel or the valve-release cabinet deenergizes relay CR-2, closing its contacts to operate the trouble bell. The bell will continue to ring until conditions are again normal.

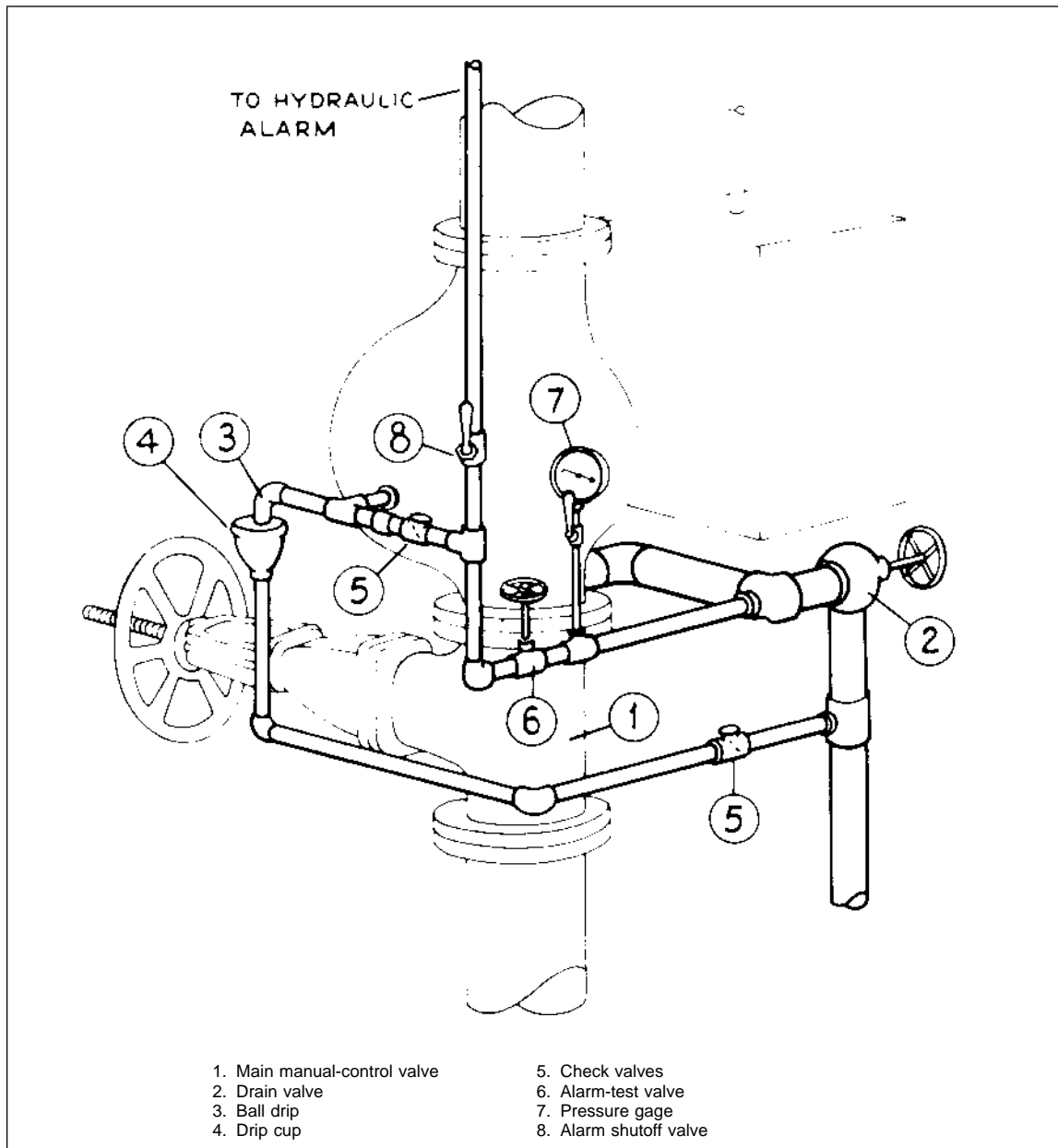

Fig. 173. Central Model AD water-control valve.

SETTING (Figs. 169 & 173)

1. Close the main manual control valve of the system.
2. Open the drain valve (2) below the automatic water-control valve to drain the system.
3. Remove the cover plate from the automatic water-control valve and carefully wipe the rubber facing of the valve seat and the face of the valve clapper. Clear access openings in the seat ring of any obstructing material. Open the release-cabinet cover.
4. Close the drain valve and open the main manual water-control valve slightly, admitting water very slowly under the clapper until it flows out of the small safety port in the face of the cover opening. When water appears, close the main manual water-control valve.
5. Release the latch F, and lower the clapper to its seat.
6. Pull trip-lever B to the right until its toe engages the edge of the valve clapper.
7. To set the release mechanism, grasp vertical lever L with the right hand and move it to the right, releasing locking plunger N from its seat in the recess in the underside of cam lever K. Simultaneously, with the left hand, push the cam lever upward so that it rotates about the ball joint K₁ moving bearing rod C downward to press against the trip-lever and to rest on the stop-boss provided. This action automatically resets limit switch Q and the pull chain S. If the release mechanism will not reset, make certain that sufficient time has elapsed for thermostats to compensate. Examine the thermostats, look for "faults" in the circuit wiring and see that manual emergency stations have been returned to their off-position. Replace any fused thermostats and correct any wiring defects found.
8. Replace the valve cover plate and release cabinet door and bolt securely.
9. Open system drain valves and close after all water has been removed from low points.
10. Slowly open the main manual water-control valve. If there is no leakage past the deluge-valve clapper, as evidenced by discharge into the drip cup, open the main manual-control valve wide.
11. Test the drain valve below the automatic water-control valve. Then seal in the open position all manual water-control valves that have been operated. The system is now in service.

MAINTENANCE AND INSPECTION

The manufacturer or installer of the systems offers a maintenance and inspection service under various contract forms. Unless the plant has specialized personnel who can adequately test and maintain the systems, it is advisable to purchase one of these service contracts. Generally, the manufacturer or installer should be contacted to make repairs and adjustments except minor or routine items.

Test the waterflow alarm each week. Inspect all manual-control valves weekly to make certain they are wide open and sealed.

Check the storage battery each month. See that the charge regulating switch on the power-unit panel (3-Fig. 171) is in the normal trickle charge position. Then depress the test switch (1) on the panel for an interval no greater than ten seconds, noting the voltmeter (2) during this operation. Operation of the test switch transfers the standby battery to a phantom load equivalent to the solenoid release during a deluge valve operation. If the reading is below the 32 to 36 volt range, change the charge-regulating switch to the boost position for about twelve hours. At the end of this time, move the switch to the normal position and repeat the test. If the voltage continues to be less than 32 to 36 volts, the battery should be replaced.

Check the water level and specific gravity by observation of the small colored balls in the batteries.

Test automatic transfer to emergency power supply. Frequency of test should not be less than the frequency of Factory Mutual inspections.

1. Remove the outer casing of the power unit (Fig. 171).
2. Depress the test switch on the panel of the power unit for a maximum of ten seconds.
3. While this switch is open, observe that the transfer relay is deenergized, that the alarm bell rings and that the pilot light on the control panel dims to very faint light.
4. Replace casing on the power unit.

Make operational trip-tests once a year. Where water discharge is permissible, conduct one of the three operational tests (4, 6 or 7 below) with the main manual-control valve at least partly open. For the other two tests it may be in the closed position.

1. Connect the electric test-set to a 110/120-volt supply about 15 minutes before testing begins.

CAUTION: In areas where there are hazardous materials, use a small container of hot water instead of the test-set.

2. Notify the fire department, central-station supervisory service or other agencies which may receive signals during the tests.
3. Close the main manual control valve and open the 2-in. drain below the automatic water-control valve.
4. Apply the heat source to the most remote thermostat or the test thermostat if one is provided. Note the time required to trip the automatic release. Operation should occur in 5 to 25 seconds. If tested with the main manual-control valve open, observe that the Model AD valve tripped and the clapper and latch functioned properly.

CAUTION: If the heating test is continued for more than 35 seconds, there is possibility of operating the fixed-temperature release feature of the thermostat, which will require replacement of the thermostat.

5. Wait a few minutes after removing the heat source from the thermostat for the rate-of-rise feature to return to normal and open its contacts. Reset the release mechanism as described under SETTING.
6. Operate the release mechanism manually by pulling the hand knob located at the side of the release cabinet.
7. Where remote break-glass stations are provided, again reset the release mechanism. These stations are connected to the thermostat wiring loop in the same manner as a thermostat. Unlock and open the cover, thereby short-circuiting the thermostat lines, causing the deluge valve to operate and the trouble gong to sound. Close and lock the cover.
8. Examine the automatic water-control valve internally, clean the clapper and seat, and return the system to service as described under SETTING.

4.5 Grinnell Model B

Grinnell Flooding Valve MODEL B, 2 INCH (51 mm) 1941 TO DATE

Grinnell Fire Protection Systems Co. Providence, R.I.

DESCRIPTION

The Grinnell Model B flooding valve (Fig. 174) is a deluge type of valve used primarily for automatic control of small water spray protection systems. Under normal conditions the center valve assembly 5 is held closed by water pressure acting on rubber diaphragm 6 and diaphragm retaining ring 7. Water pressure is admitted through the restricting orifice D (Fig. 175) in the equalizing bypass line from below the main supply valve. Whenever water pressure is released to atmosphere faster than it can be supplied through the restricting orifice, the deluge valve will trip. Pressure is released from the upper chamber by one of the following methods:

1. **Automatic:** Operation of one or more closed sprinklers in the wet or dry pilot line.
2. **Manual:** Opening of one or more valves arranged for remote or local operation of the flooding valve.

The Model B-1 dry pilot actuator permits sprinklers to be installed in locations subject to freezing temperatures. Release of pressure from the pilot line moves the actuator diaphragm, opening a port and releasing water pressure in the upper chamber of the flooding valve. The dry pilot line may be pressurized with air or nitrogen.

Air Pilot Line

A pressure switch on the air pilot line (Fig. 176) is diaphragm operated and has two sets of single-pole double-throw contacts set for a normal pressure exposure of 30 psi (207 kPa)(2.07 bars). One set of contacts actuates a trouble horn upon a loss of 6 psi (41 kPa)(0.41 bars) in pilot line pressure. The other set of contacts actuates a fire alarm gong upon a loss of 15 psi (103 kPa)(1.03 bars) in pilot line pressure.

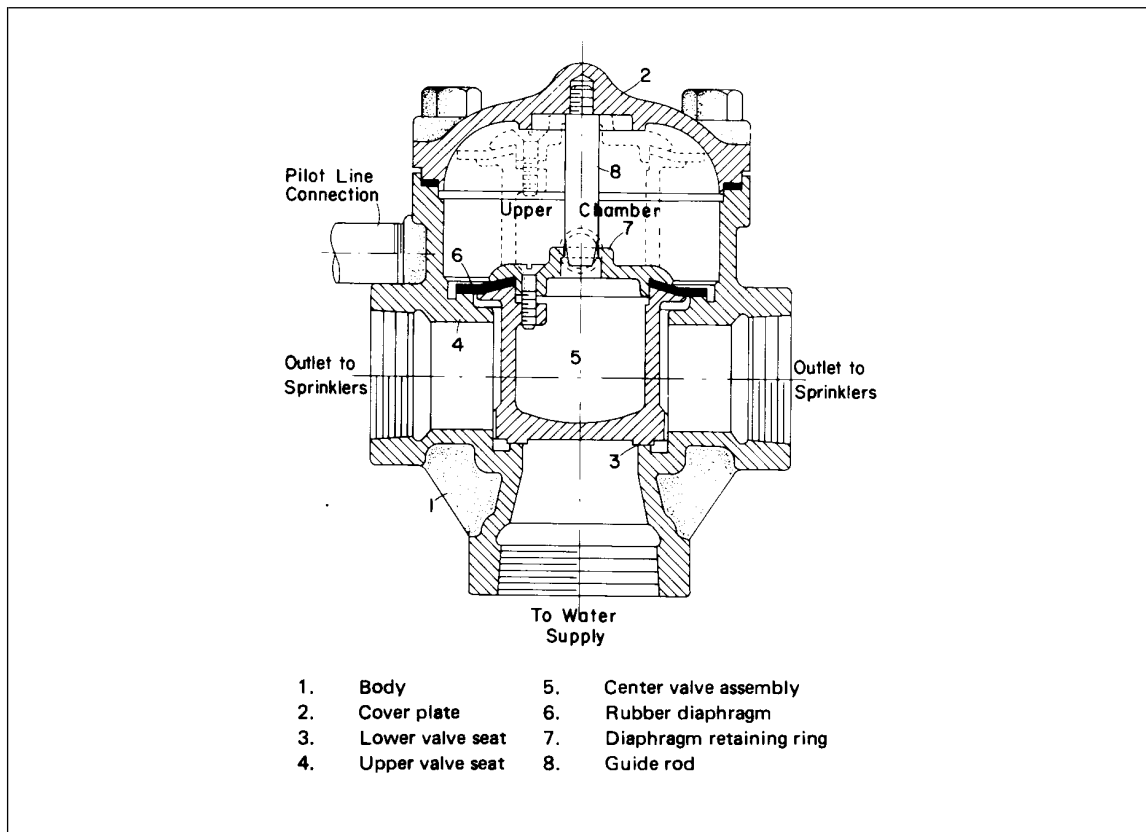

Fig. 174. Grinnell flooding valve Model B.

Nitrogen Pilot Line

The nitrogen pilot line (Fig. 177) has a diaphragm operated pressure switch with three sets of single-pole double-throw contacts set for a normal pressure exposure of 30 psi (207 kPa)(2.07 bars). Two sets of contacts - one set to close on a rise of 6 psi (41 kPa)(0.41 bars) in pilot line pressure and one set to close on a drop of 6 psi (41 kPa)(0.41 bars) in pilot line pressure - actuate a common trouble horn. The third set of contacts activates a fire alarm gong upon a pilot line pressure loss of 15 psi (103 kPa)(1.03 bars).

OPERATION

Deluge Valve

When system pressure is released, either manually or automatically, water pressure in the upper chamber is vented faster than it can be replaced through the restricting orifice. Pressure is reduced sufficiently to allow the supply pressure to force center valve assembly open.

Model B-1 Actuator

See Data Sheet 2-91, page 8.

SETTING

Deluge valve only (Fig. 175)

1. Close main control valve A and equalize bypass control valve C.
2. Open main drain valve B, making sure system has drained completely by pushing plunger of drip check valve E.
3. Open all drain valves and vents at low points throughout the system; close them when water ceases to flow.
4. Remove cover and center valve assembly 5 (Fig. 174).

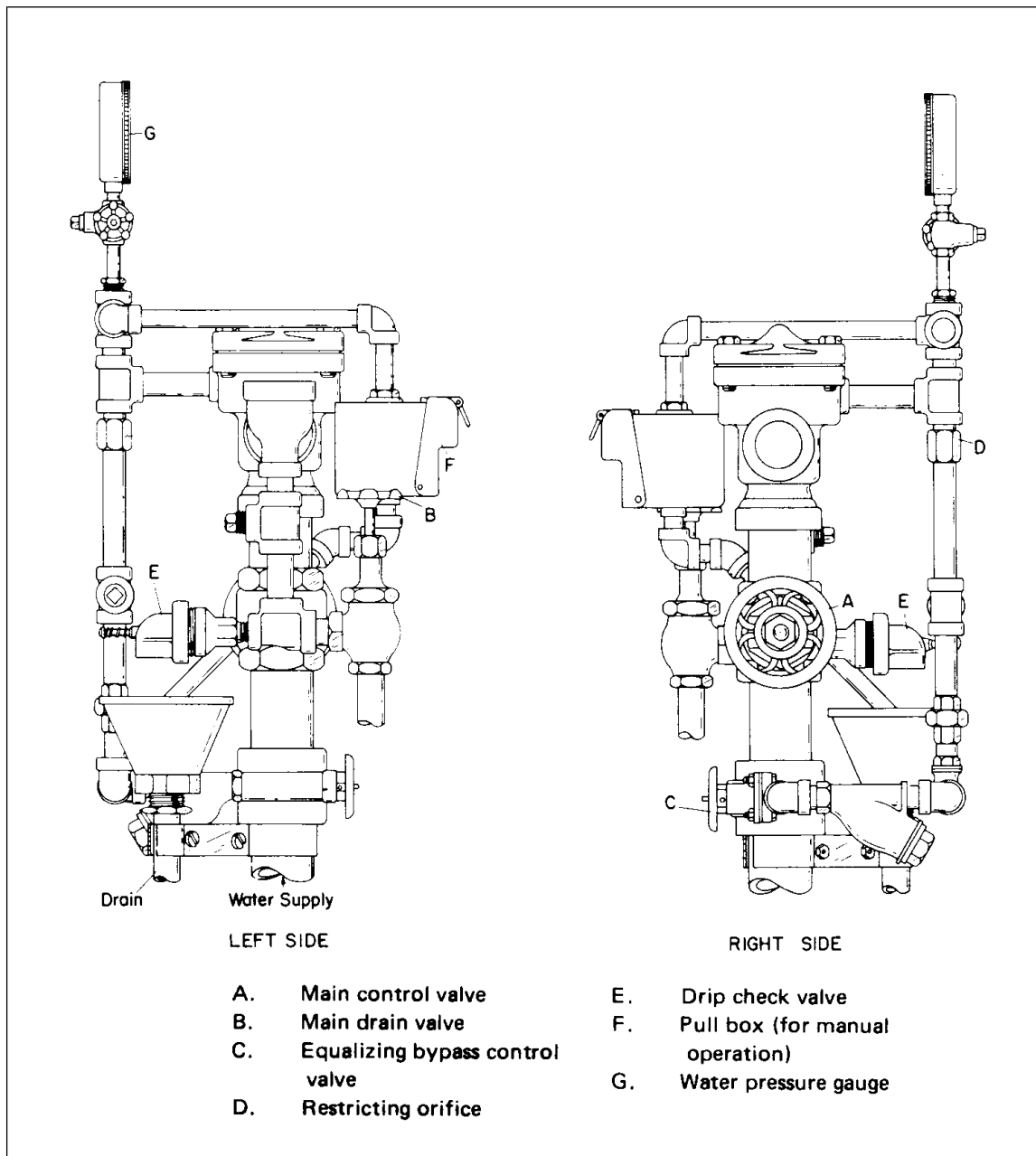

Fig. 175. Grinnell flooding valve trim.

5. Carefully clean upper valve seat 4, lower valve seat 3, and those surfaces of the center valve assembly that rest on these seats.
6. Replace center valve assembly 5.
7. Replace cover.
8. Open the equalizing bypass control valve C and fill the upper chamber and pilot line until water pressure at gauge G indicates a static condition.
9. Slightly open main control valve A and observe if any water leaks past the drip check valve E or main drain valve B.
10. If no leak appears, open wide the main control valve A and close main drain valve B.

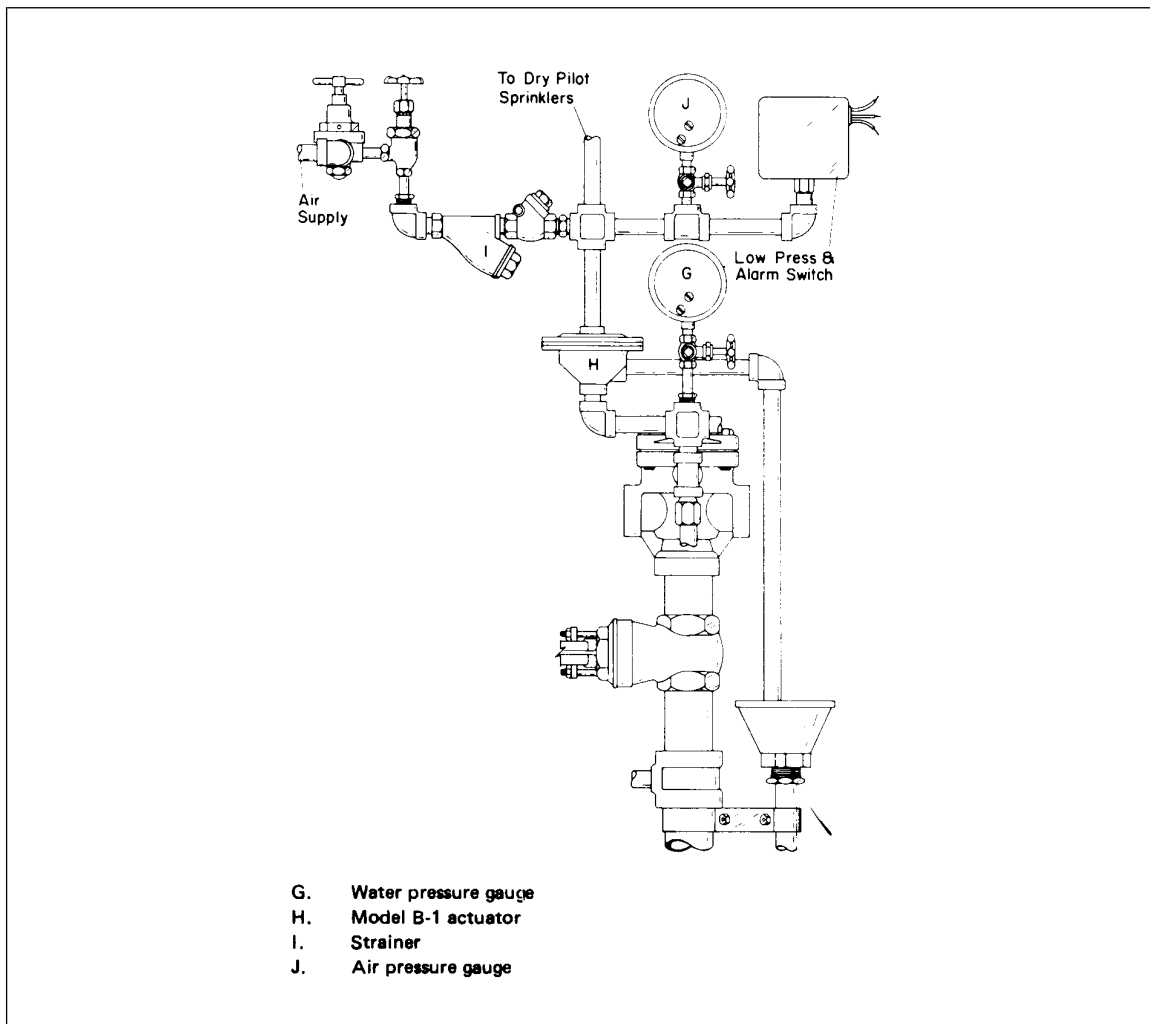

Fig. 176. Grinnell flooding valve trim (air pilot line).

Deluge Valve with Model B-1 Actuator (Air and Nitrogen Pilot Lines)

After main control valve is closed and before resetting of flooding valve, the dry pilot actuation system must be reset.

1. Perform Steps 1 to 7 as outlined above under **SETTING-Deluge Valve**.
2. Close the nitrogen or air cylinder control valve.
3. Replace the pilot line sprinklers that were affected.
4. Reset the control station if the system was operated from a pneumatic manual control station. The Grinnell Pneumatic Break-Glass Manual Control is reset by pushing the interior operating lever up, closing the hinged cover, and inserting a new break-rod through the small hole in the top of the enclosing assembly.
5. Slowly open the nitrogen or air cylinder control valve and allow the pressure to build up in the dry pilot line and actuator. When the pressure gage indicates the required pilot line pressure (normally 30 psi 207 kPa)(2.07 bars), turn the nitrogen or air cylinder control valve to a full open position.

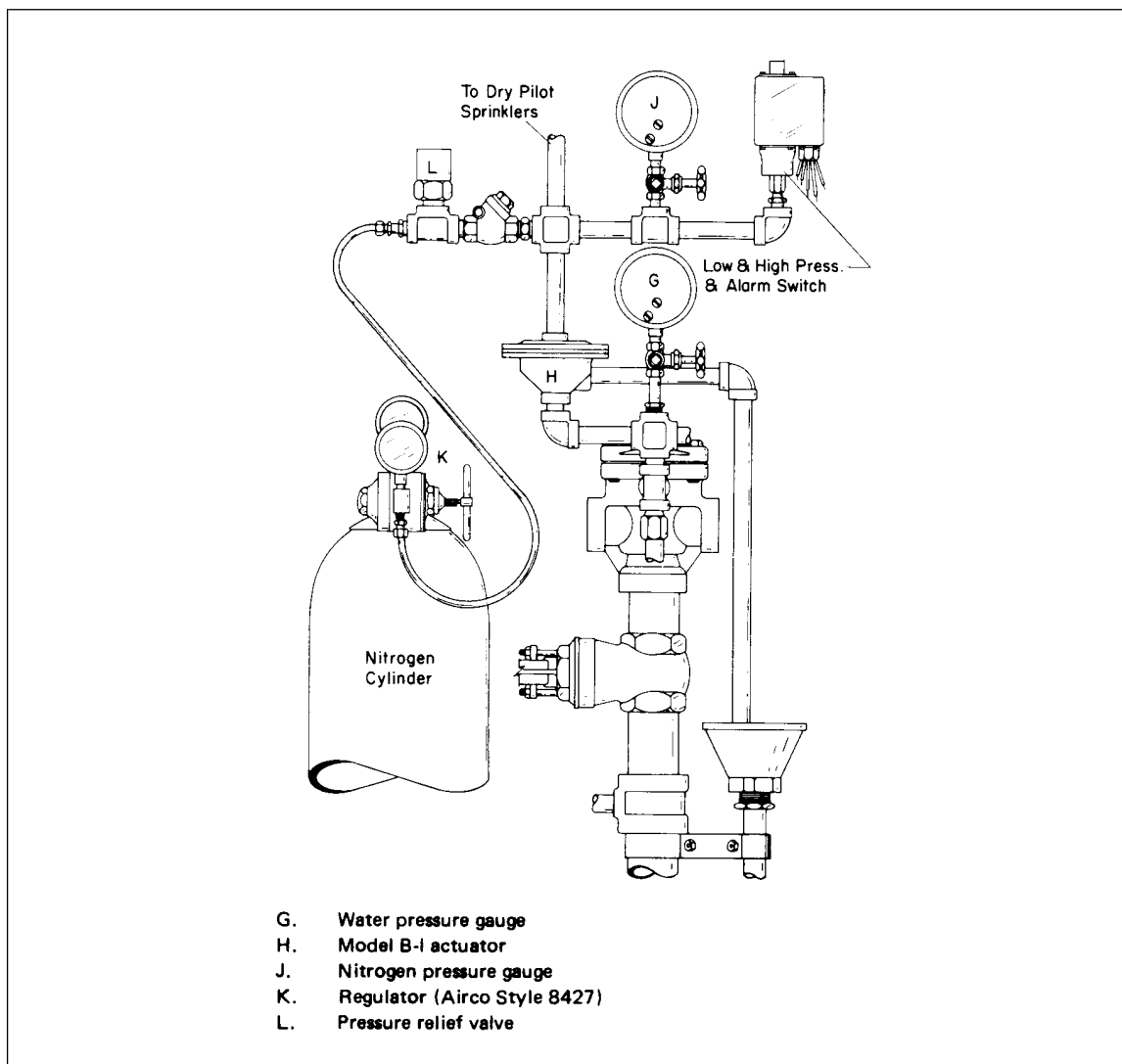

Fig. 177. Grinnell flooding valve trip (nitrogen pilot line).

4.6 Grinnell Multimatic Deluge and Preaction System

Deluge and Preaction Systems With Grinnell Multimatic Valve Model A-4 4 in. & 6 in. — 1962 to Date

Grinnell Corp., Providence, Rhode Island 02901

INTRODUCTION

The Grinnell multimatic Valve Model A-4 is designed to control the flow of water to special extinguishing systems of open sprinklers, spray nozzles, or mechanical foam-making equipment and to preaction sprinkler systems.

The basic trim (Fig. 179) provides for manual operation of the valve by means of a break-glass manual control station. Accessory devices and connections are available

OPERATION OF THE MULTIMATIC VALVE

Under normal conditions, the water pressure under the clapper (11, Fig. 178) and on the diaphragm (12, Fig. 178) are equal. The clapper latch (10, Fig. 178) holds the clapper closed by force applied from the diaphragm to the clapper latch push rod and flange assembly (8, Fig. 178).

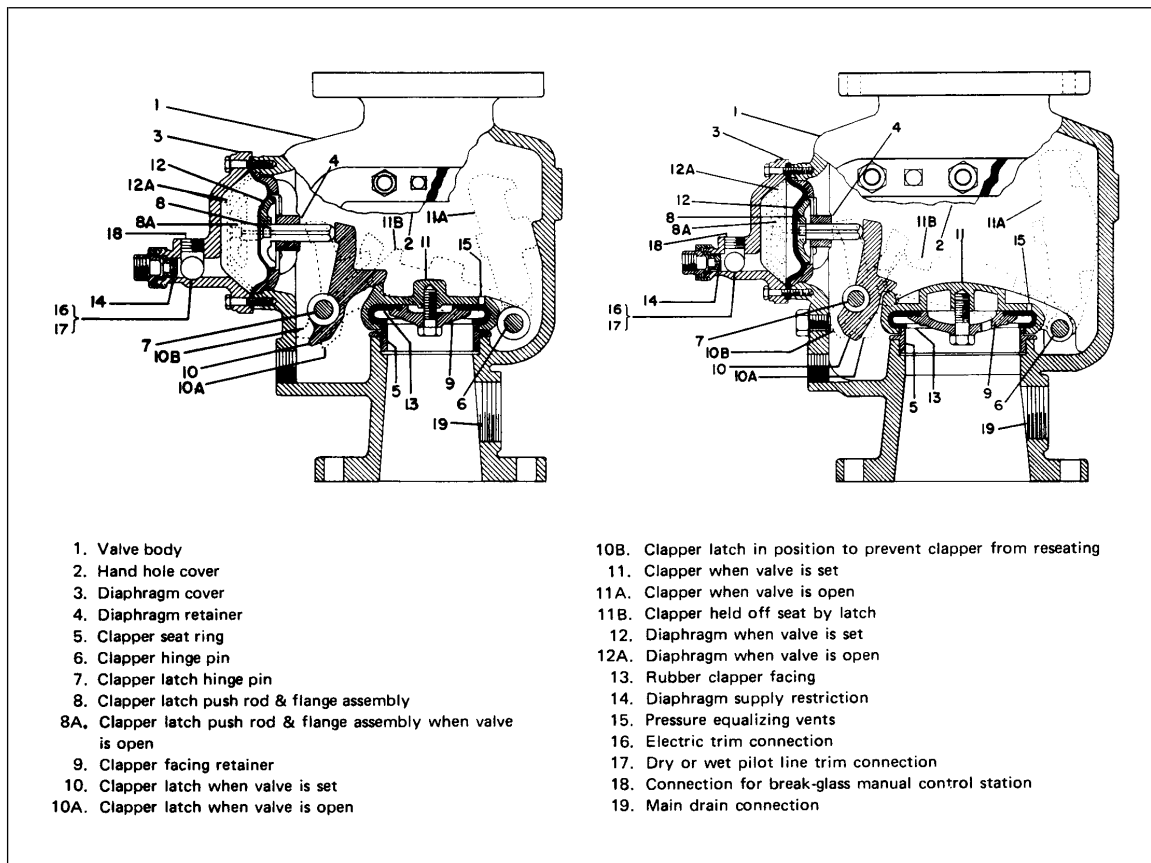

Fig. 178. Grinnell Multimatic valve Model A-4, 4-inch (left) and 6-inch (right).

The clapper with its rubber facing (13, Fig. 178) is held firmly against the seat ring (5, Fig. 178).

Automatic actuation of the Multimatic valve is accomplished by the operation of an electric thermostat, a dry pilot line sprinkler, or a wet pilot line sprinkler connected to the proper actuating device connection (16, 17, or 18, Fig. 178). The valve may be manually actuated at the valve by operation of an hydraulic break-glass manual control station (13, Fig. 179).

Operation of any of the actuating devices will, by means of the appropriate trim arrangement, cause a release of water from the diaphragm chamber of the valve at a rate greater than that at which it can be replenished through the diaphragm supply restriction (14, Fig. 178). This causes a rapid pressure drop in the diaphragm chamber. Water pressure on the underside of the clapper is then greater than the pressure against the diaphragm and the push rod and flange assembly. The pressure on the underside of the clapper forces the clapper to rise. The rising clapper forces the clapper latch to pivot on the latch hinge pin (7, Fig. 178) and force the push rod and flange assembly, and the diaphragm to positions 8A (Fig. 178) and 12A (Fig. 178) respectively.

The clapper continues to rise, pivoting on the clapper hinge pin (6, Fig. 178) until full open position 11A (Fig. 178) is reached. In this position, the Multimatic valve allows an unobstructed straight-through flow of water.

When the water flow has ceased, the clapper latch will be in position 10B (Fig. 178) and will prevent the clapper from reseating. The Multimatic valve must then be reset and restored to service.

TRIM

In addition to the basic trim (Fig. 179), the valve may be equipped with one or more of the following trim arrangements: (1) electric actuation (Fig. 180 and 181; (2) dry pilot actuation (owner's air supply) (Fig. 182); (3) dry pilot actuation (nitrogen supply) (Fig. 183); (4) wet pilot actuation.

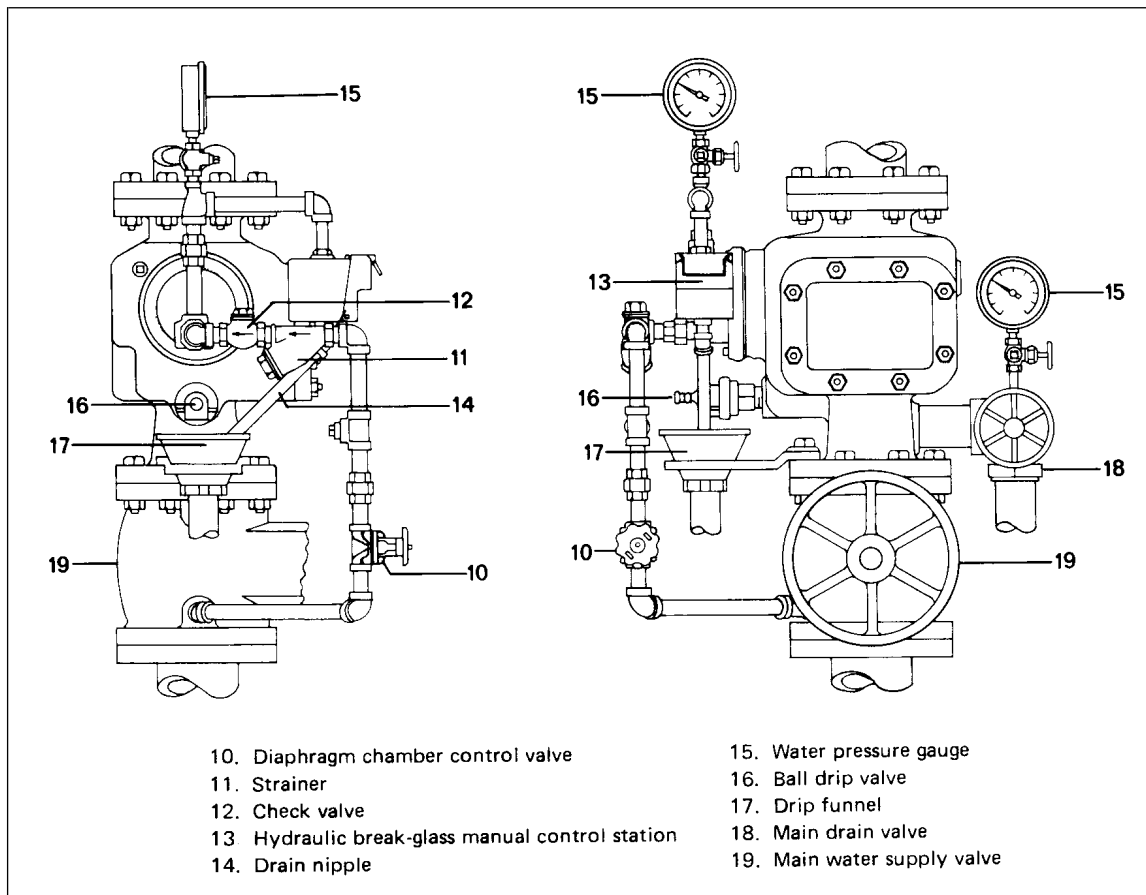

Fig. 179. Grinnell Multimatic valve Model A-4 with basic trim.

Other attachments to the valve may include one or more of the following: (1) alarm and test trim (Fig. 184) to which may be attached a water motor alarm and pressure switch for an electric alarm, or for shutdown or startup of electrical equipment; (2) remote manual actuation by hydraulic, electric, or pneumatic break-glass stations; and (3) air pressure supervision in a preaction system.

ELECTROSPRAY DELUGE AND PREACTION SYSTEMS

The arrangement of the Electro spray Deluge System is as shown in Fig. 181 with the check valve and drain downstream from the Multitrol valve and the air supervisory trim removed. Sprinklers are open or spray nozzles are used. The Electro spray preaction system is as shown in Fig. 181. Both systems are actuated electrically.

Resetting the deluge system would follow the procedure indicated for an electrically actuated system. Resetting the preaction system involves also replacement of all sprinklers which have actuated and repair of all other leaks in the pneumatic system. The preaction system normally carries 1 1/2 psi (10.3 kPa) air pressure, automatically supplied by an air pump in the supervisory air panel.

OPERATION OF THE MULTIMATIC VALVE EQUIPPED WITH VARIOUS TRIM ARRANGEMENTS

With Electric Actuation. In the set condition, the solenoid valve (1, Fig. 180) and (5, Fig. 181) is closed. Operation of an electric thermostat or manual control causes the solenoid valve to open. This allows the discharge of water from the diaphragm chamber of the Multimatic valve, which then operates as outlined under **OPERATION OF THE MULTIMATIC VALVE.**

With Dry Pilot Actuation with Air. In the set condition, the dry pilot actuator (1, Fig. 182) is held closed by air pressure in the dry pilot line. Opening of a pilot line sprinkler or operation of a pneumatic remote control relieves the pressure from above the diaphragm of the actuator, allowing it to open. This allows a discharge of water from the diaphragm chamber of the Multimatic valve which then operates as outlined under

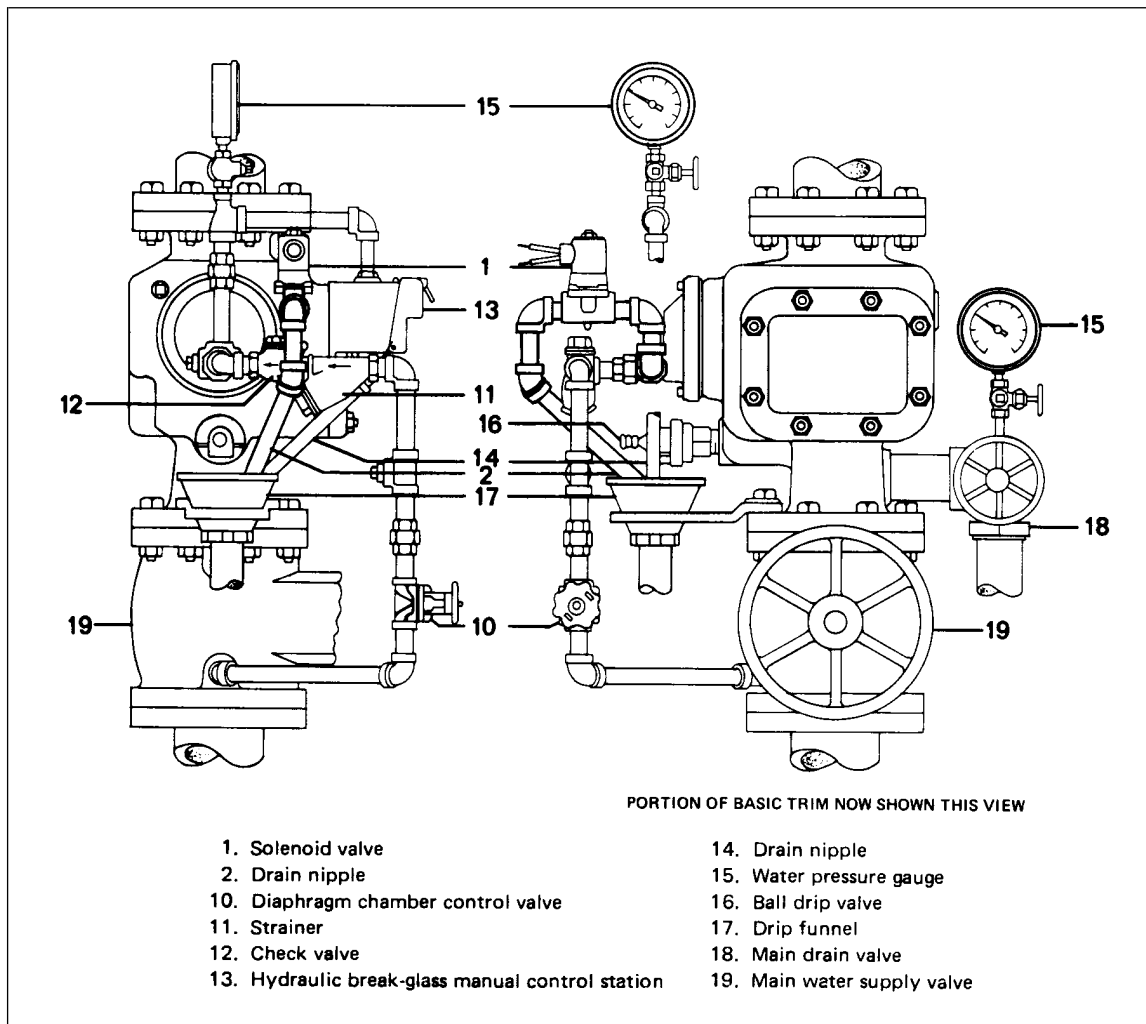

Fig. 180. Grinnell Multimatic valve Model A-4 with electric actuation trim and basic trim.

OPERATION OF THE MULTIMATIC VALVE. The low pressure and alarm switch (9, Fig. 182) is diaphragm-operated and has two sets of single-pole, double-throw contacts set for a normal pressure of 30 psig. One set of contacts actuates a trouble alarm upon a loss of 6 psi in pilot line pressure. The other set of contacts actuates a fire alarm upon a loss of 15 psi pilot line pressure.

With Dry Pilot Actuation with Nitrogen. Operation is as in the preceding paragraph except that the pressure switch (9, Fig. 183) has three sets of single-pole, double-throw contacts set for a normal pressure of 30 psig. One set of contacts closes on a rise of 6 psi in pilot line pressure and another set closes on a drop of 6 psi; these two sets actuate a common trouble alarm. The third set actuates a fire alarm upon a pilot line pressure loss of 15 psi.

With Alarm and Test Trim. In the set condition, the indicator of the three-way alarm control and test cock (1, Fig. 184) is in the alarm position. When the Multimatic valve operates, the flow of water through the alarm and test trimmings actuates the pressure switch (9, Fig. 184) and operates the water motor alarm. To silence the alarm during operation of the system, turn the alarm control and test cock to the OFF position.

RESETTING

With Basic Trim.

1. Close the main water supply valve (19, Fig. 179).
2. Close the diaphragm chamber control valve (10, Fig. 179).

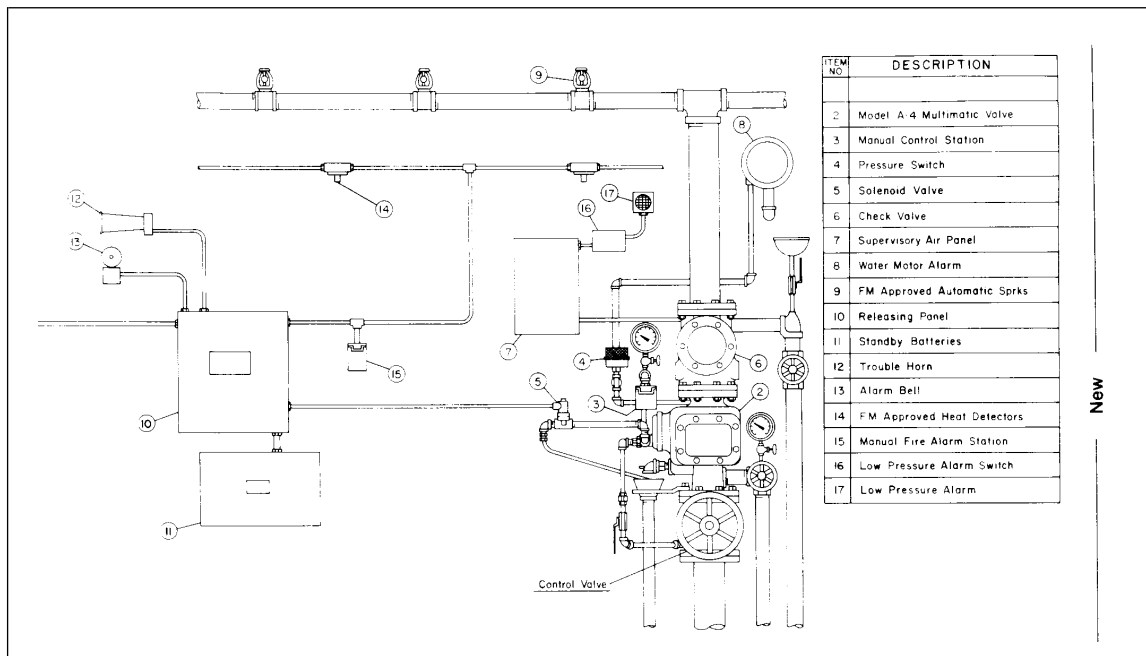

Fig. 181. Grinnell Electro Spray preaction system.

3. Open main drain (18, Fig. 179) and allow system to drain.
 4. Open auxiliary drain valves and plugs at low points in the system. Close when water ceases to drain.
 5. Depress the push rod of the ball drip valve (16, Fig. 179) to be sure it is open and that the Multimatic valve has drained.
 6. Remove handhole cover (2, Fig. 178) and carefully clean all interior parts. Make sure that the pressure equalizing vents (15, Fig. 178) in the clapper (11, Fig. 178) are open and that all parts are clean and free of scale. Test the clapper, clapper latch (10, Fig. 178), and the flange and push rod assembly (8, Fig. 178) for freedom of movement.
- WARNING: NEVER APPLY GREASE OR ANY OILY SUBSTANCE TO INTERIOR PARTS OF THE VALVE.**
7. Raise the clapper and move the clapper latch to the left sufficiently to allow the clapper to be resealed. Release the clapper latch so that its foot rests on the boss of the clapper.
 8. Open diaphragm chamber control valve (10, Fig. 179).
 9. Restore break-glass manual control station (13, Fig. 179) to service by pushing its interior operating lever up until flow of water into the drip funnel (17, Fig. 179) ceases. Then, with the lever up, close the hinged cover and insert a new glass rod through the hole in the top of the enclosing box. The break-glass station is now set for operation.
 10. Allow sufficient time for full pressure to build up against the diaphragm (12, Fig. 178) through the diaphragm supply restriction (14, Fig. 178).
 11. Replace the handhole cover on its gasket and tighten handhole cover nuts. Make sure the hole in the gasket is over the orifice in the face of the valve. Water will issue from this orifice if an attempt is made to open the main gate valve before the handhole cover is secured in place.
 12. Slowly open the main water supply valve (19, Fig. 179), closing the main drain valve (18, Fig. 179) when water begins to flow from it. If water leaks past the ball drip valve (16, Fig. 179) into the drip funnel (17, Fig. 179), the Multimatic valve is not seated tightly and must be reset. If there is no leakage, the Multimatic valve is seated tightly and the main water supply valve must be opened wide.

With Electric Actuation.

1. Close the main water supply valve (19, Fig. 179).

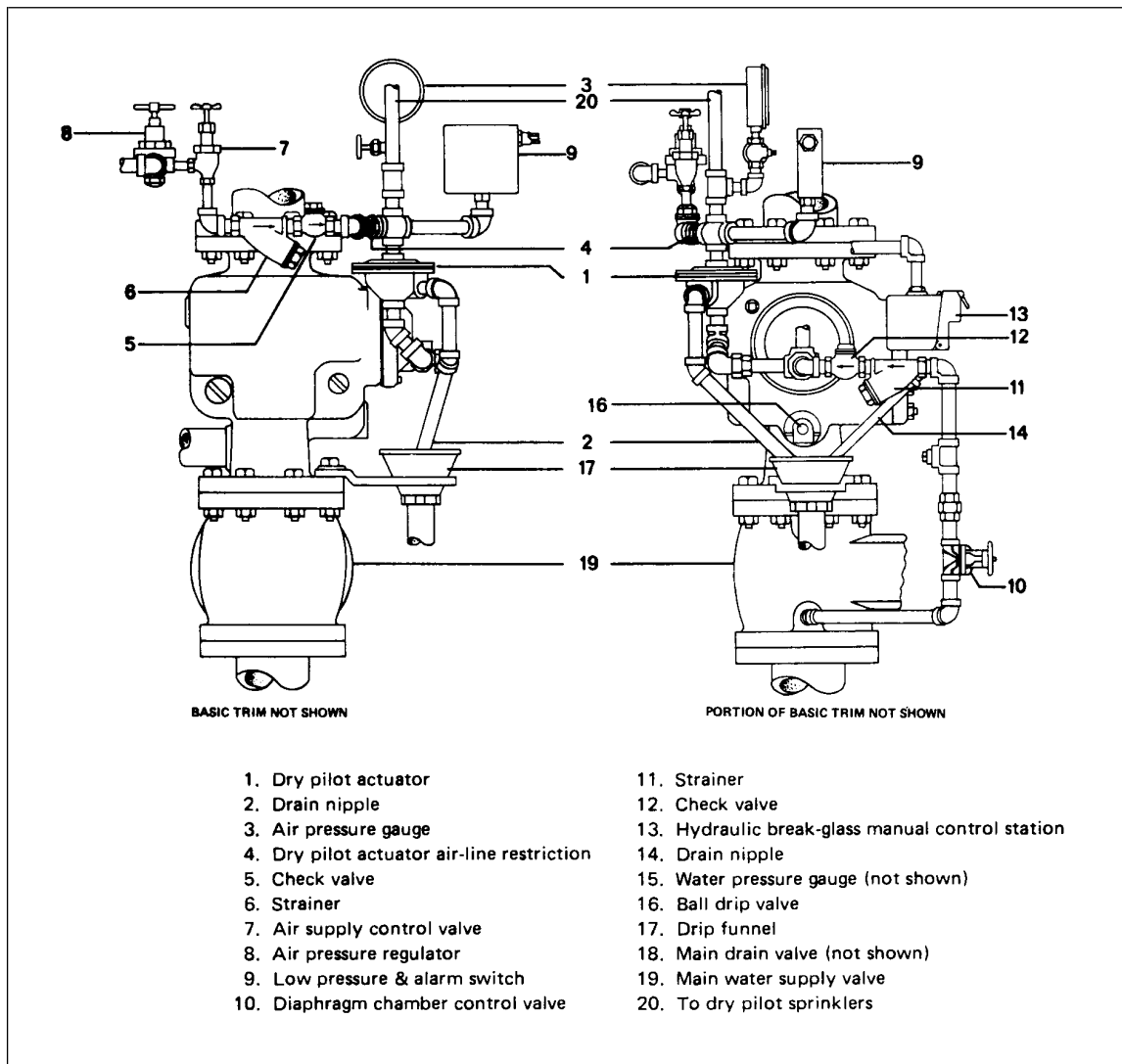

Fig. 182. Grinnell Multimatic valve Model A-4 with dry pilot actuation trim (air) and basic trim.

2. Fusible or bulb-type thermostats that have operated, or resetting-type thermostats which have suffered fire damage must be replaced.
3. If the system was operated by an electric manual control station, the control must be reset. In the case of the Grinnell Electric Break-Glass Manual Control, this is done by closing the hinged cover and inserting a new glass rod in the small hole through the top of the enclosure assembly.
4. The electric circuits should now be checked for continuity.
5. Reset the Multimatic valve as outlined under **RESETTING**, steps 2 through 12.

With Dry Pilot Actuation with Air.

1. Close the main water supply valve (19, Fig. 179).
2. Close air supply control valve (7, Fig. 182).
3. Replace all pilot line sprinklers which operated and all solder-type sprinklers which were exposed to high temperatures.

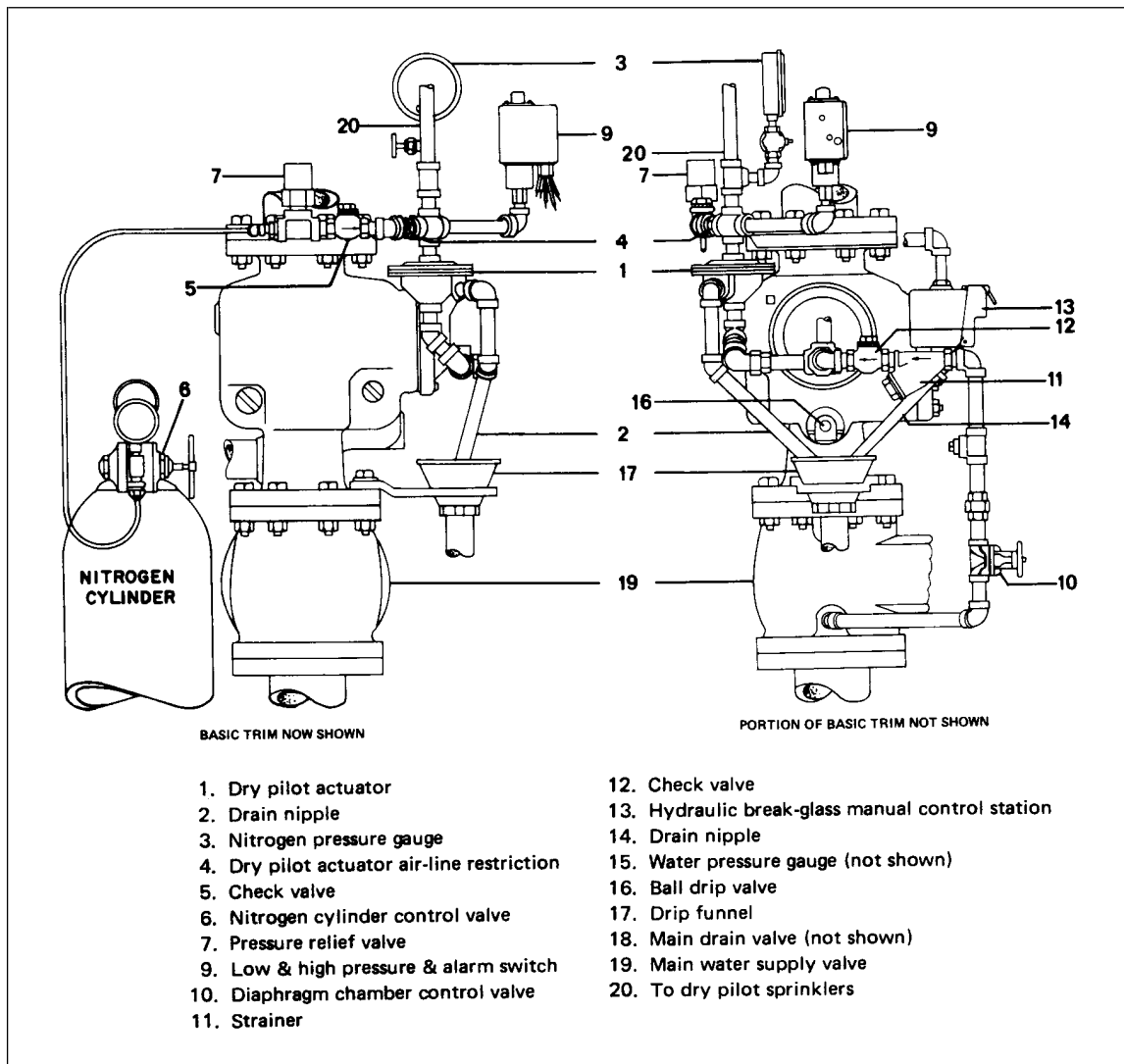

Fig. 183. Grinnell Multimatic valve Model A-4 with dry pilot actuation trim (nitrogen) and basic trim.

4. If the system was operated by a pneumatic manual control station, the control station must be reset. In the case of the Grinnell Pneumatic Break-Glass Manual Control Station, this is done by pushing the interior operating lever up, closing the hinged cover, and inserting a new glass rod through the small hole in the top of the enclosing assembly.

5. Slowly open the air supply control valve (7, Fig. 182) and allow the pressure to build up in the dry pilot lines. When the pressure gage (3, Fig. 182) indicates the required pilot line pressure (normally 30 psig), turn air supply control valve to a full open position.

6. Reset the Multimatic valve as outlined under **RESETTING**, steps 2 through 12.

With Dry Pilot Actuation with Nitrogen.

1. Close the main water supply valve (19, Fig. 179).
2. Close nitrogen cylinder control valve (6, Fig. 183).
3. See step 3 under **With Dry Pilot Actuation with Air.**
4. See step 4 under **With Dry Pilot Actuation with Air.**

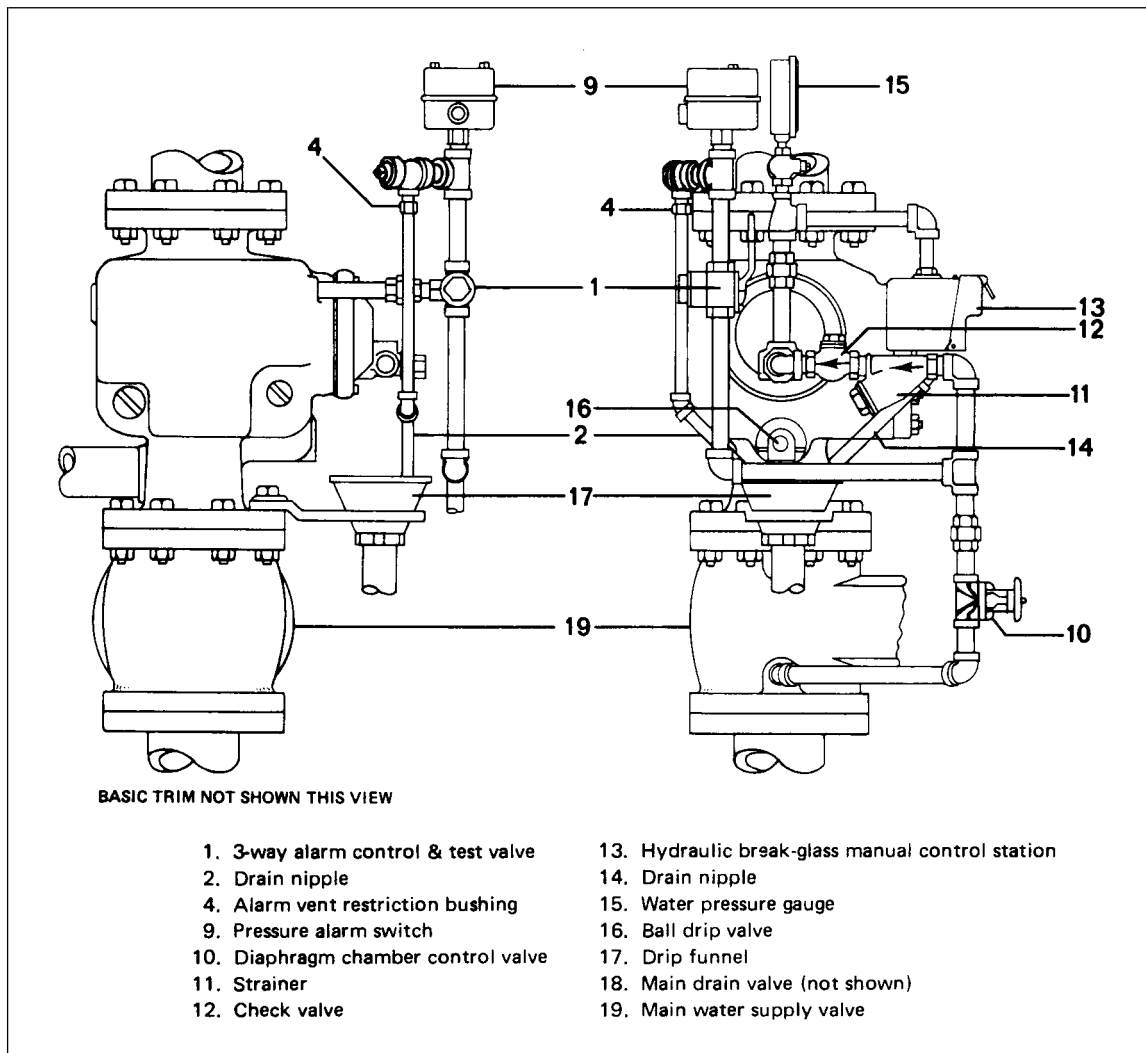

Fig. 184. Grinnell Multimatic valve Model A-4 with alarm and test trim and basic trim.

5. Slowly open nitrogen cylinder control valve and allow pressure to build up in the dry pilot lines. When the air pressure gage (3, Fig. 183) indicates the required pilot line pressure (normally 30 psig), turn the nitrogen cylinder control valve to a full open position.

6. Reset the Multimatic valve as outlined under **RESETTING**, steps 2 through 12.

With Alarm and Test Trim.

1. No resetting is necessary unless the alarms were silenced during operation of the system.
2. If the alarms were silenced, the alarm control and test cock (1, Fig. 184) must be returned to the ALARM position.
3. Reset the Multimatic valve as outlined under **RESETTING**, steps 2 through 12.

INSPECTION AND TEST PROCEDURE

With Basic Trim.

1. Close the main water supply valve (19, Fig. 179).
2. Open main drain valve (18, Fig. 179) to relieve the pressure from below the clapper (11, Fig. 178).

3. Test the operation of the break-glass manual control station (13, Fig. 179): pull the handle to open the cover and depress the interior operating lever. Water should discharge from the drain nipple (14, Fig. 179) and the operating lever should move freely. A drop of light lubricating oil may be applied if necessary. After testing, reset the break-glass manual control station as outlined under **RESETTING**, step 9.
4. Close diaphragm chamber control valve (10, Fig. 179). Remove plug from strainer (11, Fig. 179) and clean strainer basket and body. Reassemble strainer.
5. Follow steps 5 through 12 under **RESETTING**.

With Dry Pilot Actuation with Air.

1. Close the main water supply valve (19, Fig. 179).
2. Close the air supply control valve (7, Fig. 182).
3. Test operation of pressure switch and dry pilot actuator (1, Fig. 182) by slowly bleeding the pressure from the pilot lines through the inspector's test connection. The trouble alarm should operate on the loss of 6 psi in pilot line pressure, and the fire alarm should operate on an additional loss of 9 psi. A continued loss of pressure permits operation of the dry pilot actuator (1, Fig. 182) and water should discharge from the drain nipple (2, Fig. 182).
4. Close the inspector's test connection after satisfactory completion of the preceding test.
5. Inspect and if necessary clean the strainer (6, Fig. 182) and the check valve (5, Fig. 182).
6. Follow step 5 as outlined under **RESETTING-With Dry Pilot Actuation With Air**.
7. Open the main water supply valve (19, Fig. 179).

With Dry Pilot Actuation with Nitrogen. Proceed as under **With Dry Pilot Actuation With Air**, except substitute "nitrogen cylinder control valve (6, Fig. 183)" for "air supply control valve".

With Alarm and Test Trim. Turn the 3-way alarm control and test valve (1, Fig. 184) to the TEST position. This allows a flow of water to the pressure switch and the water motor alarm. The water motor alarm should operate and the pressure switch should function. After the test has been completed, reset the 3-way alarm control and test valve to the ALARM position.

Caution: When it is necessary to shut off the water supply to the piping upstream of the Multimatic valve, the main water supply valve (19, Fig. 179) should be closed. If this is not done, and if the check valve (12, Fig. 2) should leak, the diaphragm chamber loses pressure, freeing the deluge valve clapper. When upstream pressure is restored, the system piping floods and open sprinklers discharge. With the main water supply valve shut, restoration of the upstream pressure also restores any lost pressure in the diaphragm chamber; then the main water supply valve (19, Fig. 179) should be opened.

The "Valve Shut" tag procedure should be followed.

GRINNELL DRY PILOT ACTUATOR MODEL B-1

Description. The Model B-1 actuator is a normally-closed, rubber diaphragm operated valve. It is used when automatic fixed-temperature operation is desired, using a dry pilot line of sprinklers.

Operation. In the normal set position, air or nitrogen in the dry pilot line acts on the diaphragm (7, Fig. 185) to overcome the spring tension and keeps the diaphragm on its seat. Thus, water pressure is held back at the bottom opening (10, Fig. 185). Loss of pressure in the pilot line (by operation of a pilot line sprinkler) allows the spring (6, Fig. 185) to lift the diaphragm. This allows water from the Multimatic valve diaphragm chamber to be released to drain (11, Fig. 185). The Multimatic valve then operates as outlined under **OPERATION OF THE MULTIMATIC VALVE**.

4.7 Grinnell Protomatic Release Model F100**Grinnell Protomatic Release Model F100****With Multimatic Valve Model A-4****1966 To Date**

(Originally approved as Grinnell Airotrol Deluge System, 1966)
Grinnell Corp., Providence, R.I. 02901

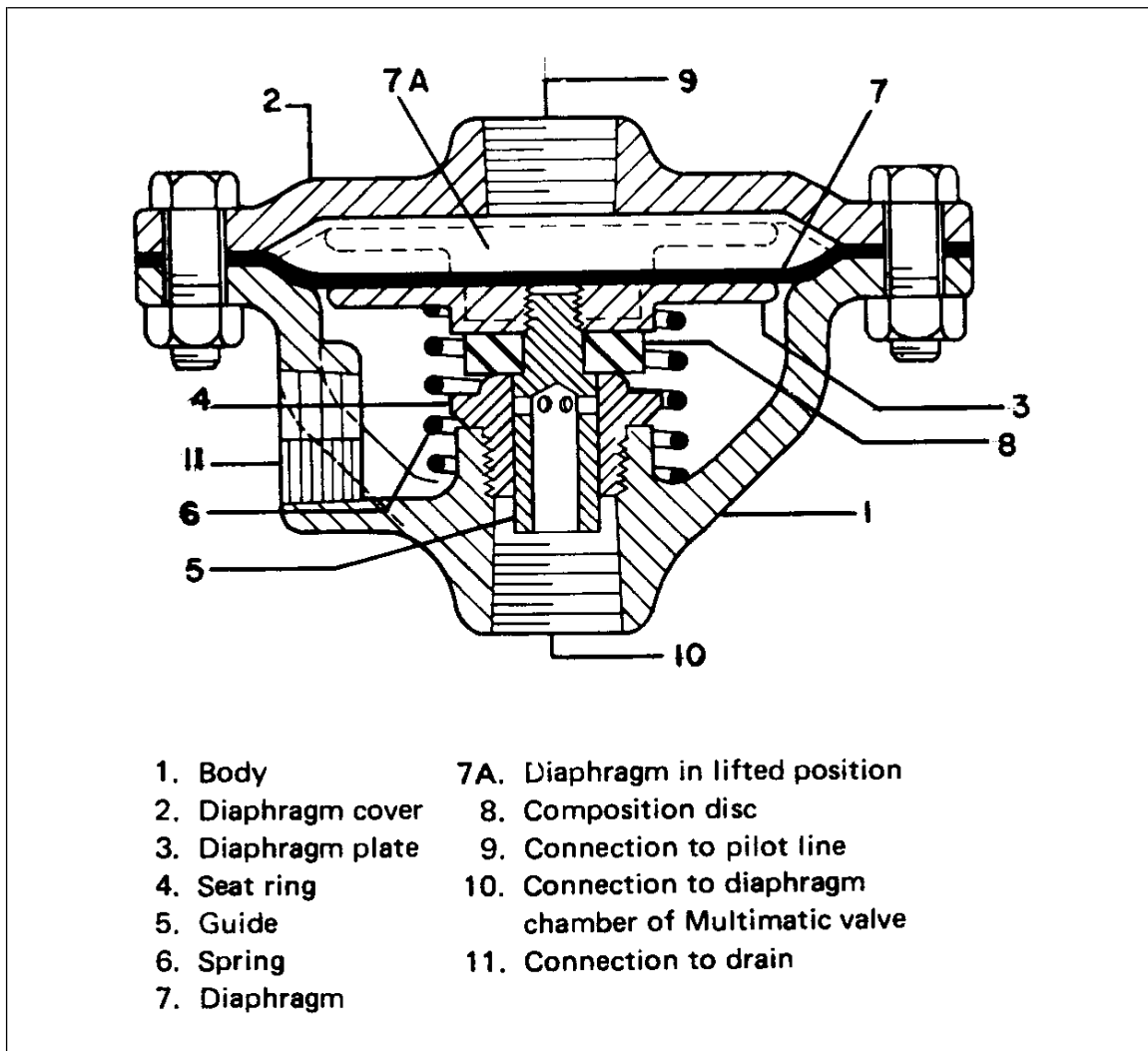

Fig. 185. Grinnell dry pilot actuator, Model B-1.

The Grinnell Protomatic system is a pressure supervised, thermopneumatically operated fire detection system for automatic actuation of deluge or special types of fire protection systems. Closed-loop tubing circuits are used for area protection while spot detectors are for the protection of specific hazards.

OPERATION OF THE PROTOMATIC RELEASE

The Protomatic release (Fig. 186) is the operating unit of the system. Its pneumatic components (Fig. 188) respond to variations in detection circuit pressures that result from a rate of temperature rise in the protected area. Calibrated venting permits changes in pressure due to ambient temperature, yet allows the release to react to fire-generated pressures and actuate the fire protection system.

Heat generated by fire raises the air pressure within the fire detection circuit. The increased pressure is exerted on the Model F 100 Protomatic release (Fig. 186) where it produces a force to operate the release. A spring within the release opens a normally closed sleeve valve assembly (9, Fig. 189) to relieve the water pressure within the diaphragm chamber (13, Fig. 187) of the Multimatic valve. When this happens, the Multimatic valve opens to admit water to the fire protection system.

The Protomatic release has two independent electric switches: a low pressure alarm switch (5, Fig. 186) to monitor supervisory pressure in the release and detection circuits, and a snap-action alarm switch (19, Fig. 186 and 6, Fig. 189) to actuate a fire alarm when the Protomatic system operates. Alternative switches are provided if additional electrical functions are required. The Model F 100 Protomatic release is for service

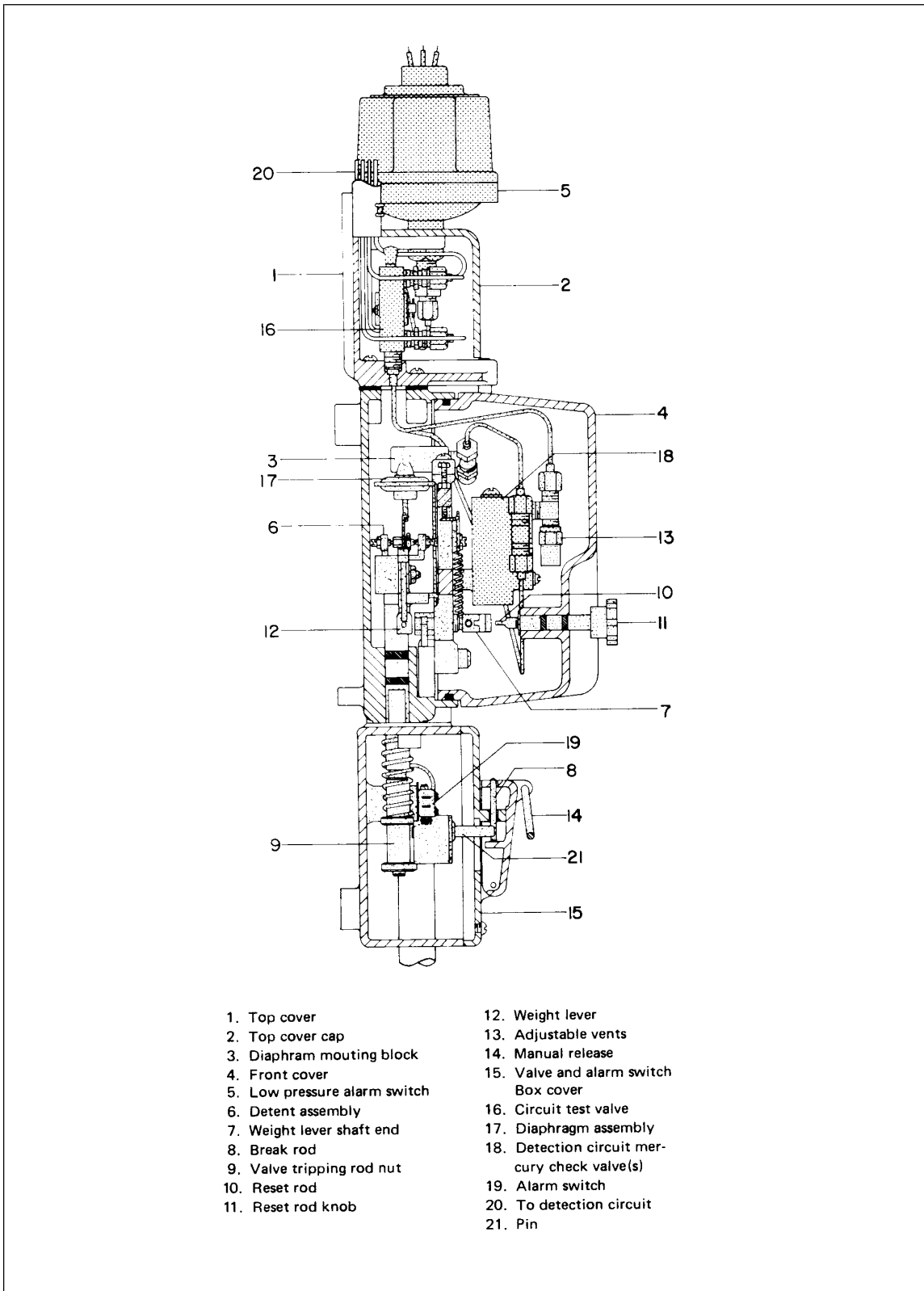

Fig. 186. Grinnell Protomatic release Model F100.

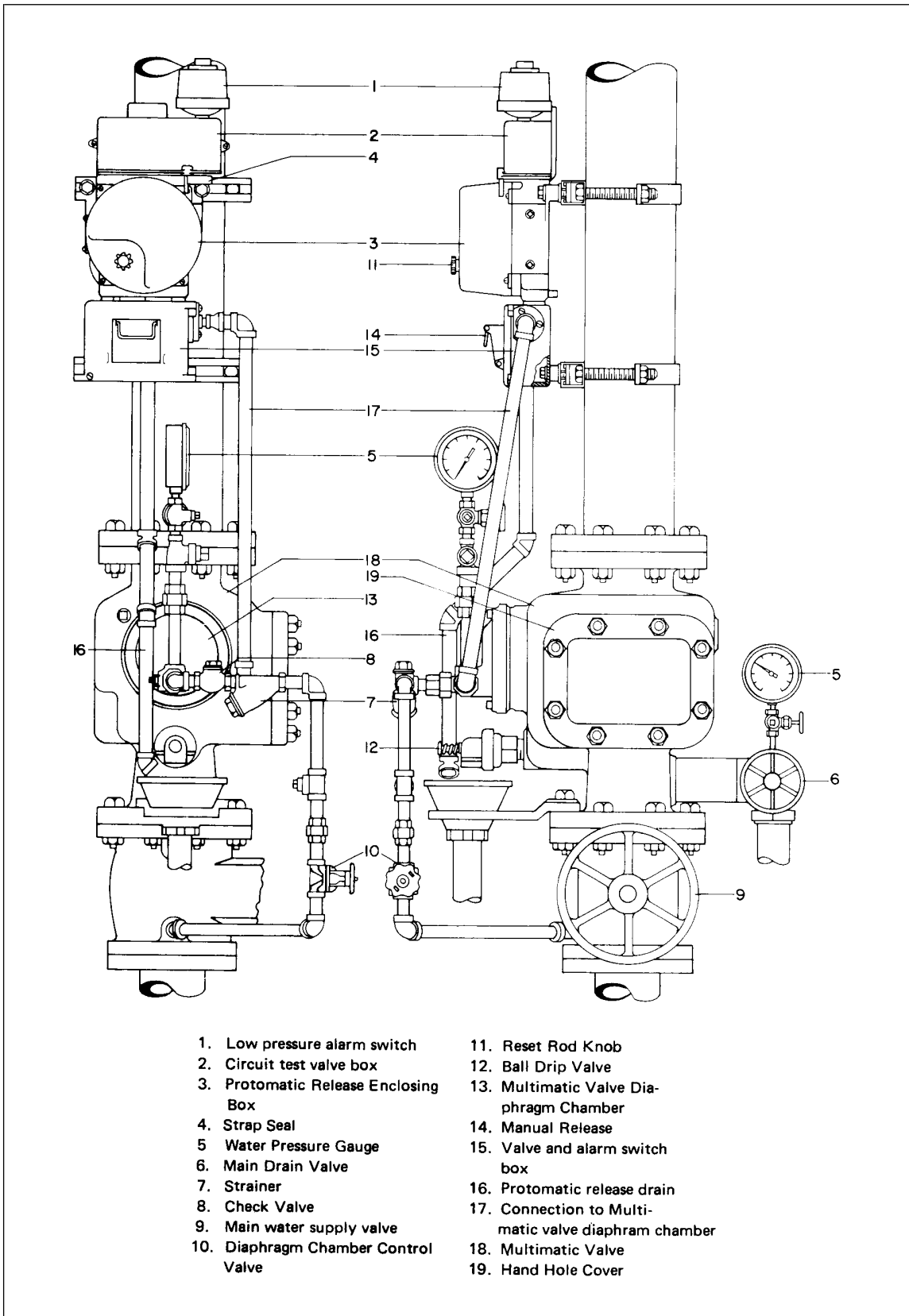

Fig. 187. Grinnell Protomatic Release Model F100, installed with Multimatic valve

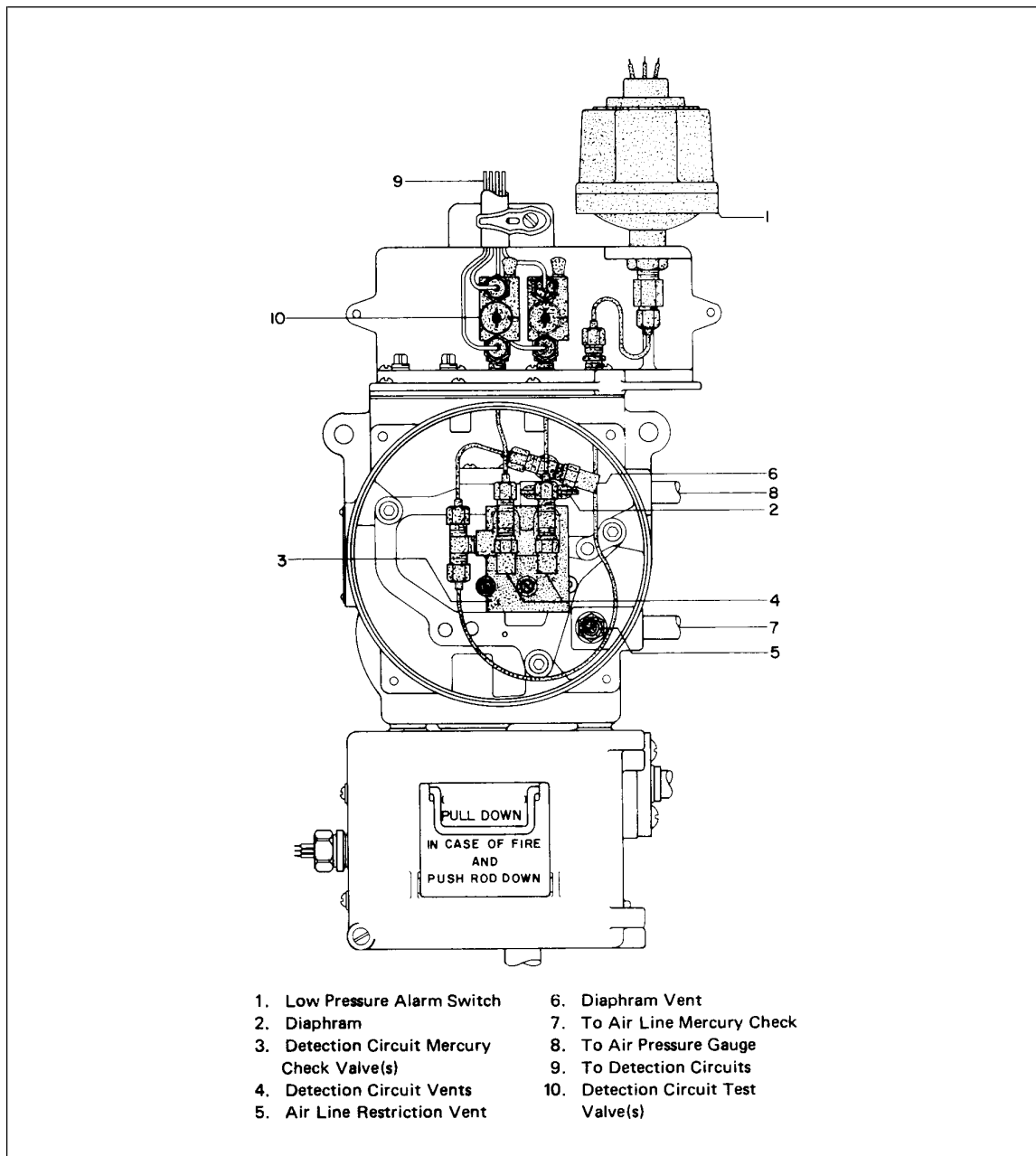

Fig. 189. Pneumatic Components of Protomatic Release.

only in those areas where no explosion hazard exists. The Model F 100X Protomatic release is for use where explosionproof electrical equipment is required. (Fig. 190 and Fig. 191).

Protomatic Detection Circuits. The Protomatic release can accommodate four detection circuits. An auxiliary enclosure for mercury checks (Fig. 193) is furnished for each additional four circuits required.

The Protomatic system utilizes two types of detection circuits:

1. A Protomatic detection tubing circuit for indoor installations only, consisting of an independent loop of partially or completely exposed circuit tubing symmetrically spaced throughout the protected area.
2. A Protomatic detector circuit for either indoor or outdoor installations, consisting of from one to six Protomatic detectors (Fig. 192) located throughout the protected area and connected in series by circuit tubing.

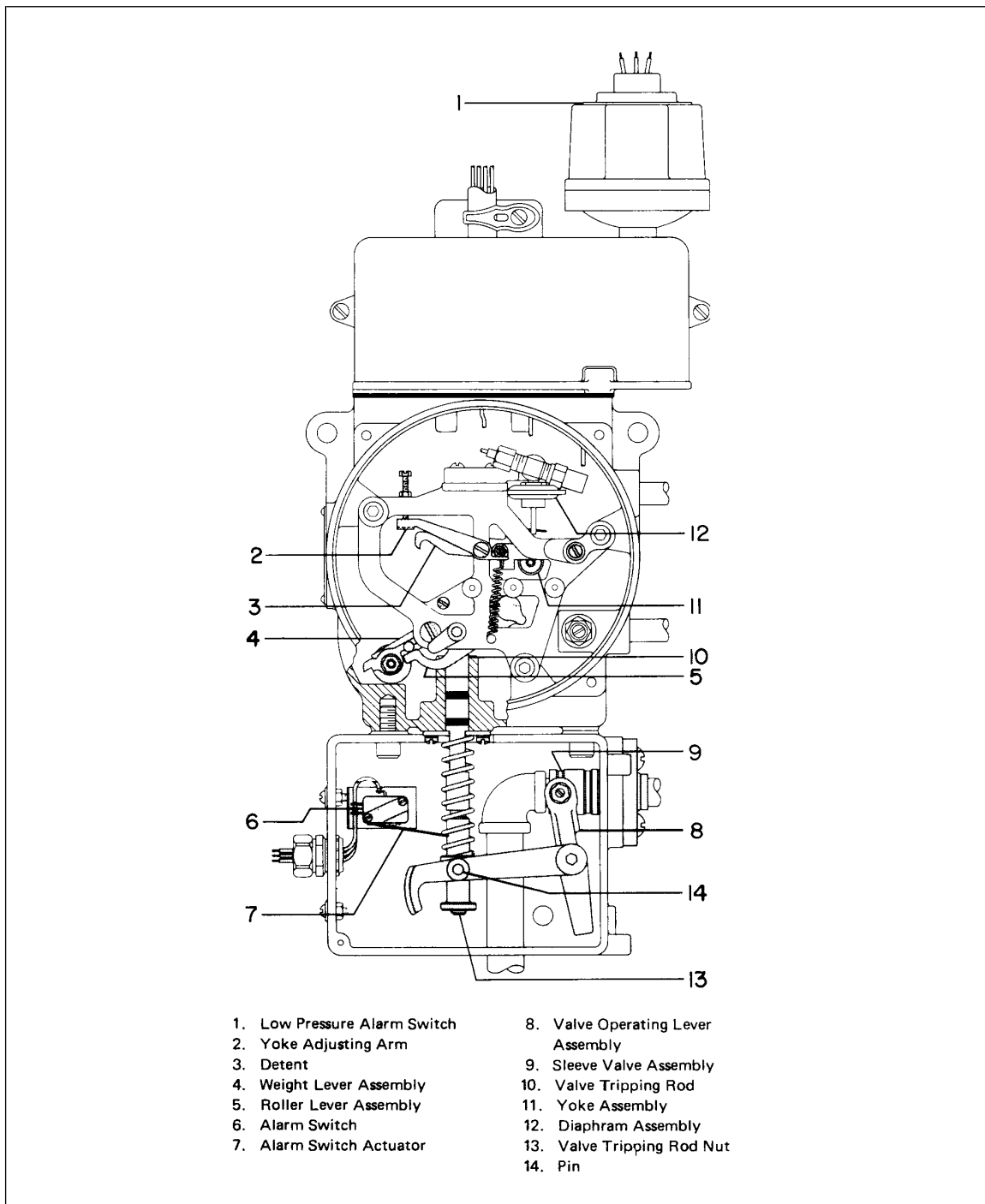

Fig. 189. Protomatic Release, Mechanical Assemblies in operated positions.

Tubing of both types of detection circuits is installed in a loop with the end of each circuit connected to its own circuit test valve (10, Fig. 188) at the Protomatic release.

Supervisory Pressure. Pressure at approximately 24 ounces per square inch for pneumatic supervision for the Protomatic system may be supplied from a Grinnell supervisory air panel (Fig. 194), a plant air system (Fig. 10), or from a cylinder of compressed nitrogen (Fig. 196) connected to the Protomatic release through an air line mercury check (15, Fig. 197).

Pressure may be supplied to closely grouped systems from a common source by use of auxiliary connections.

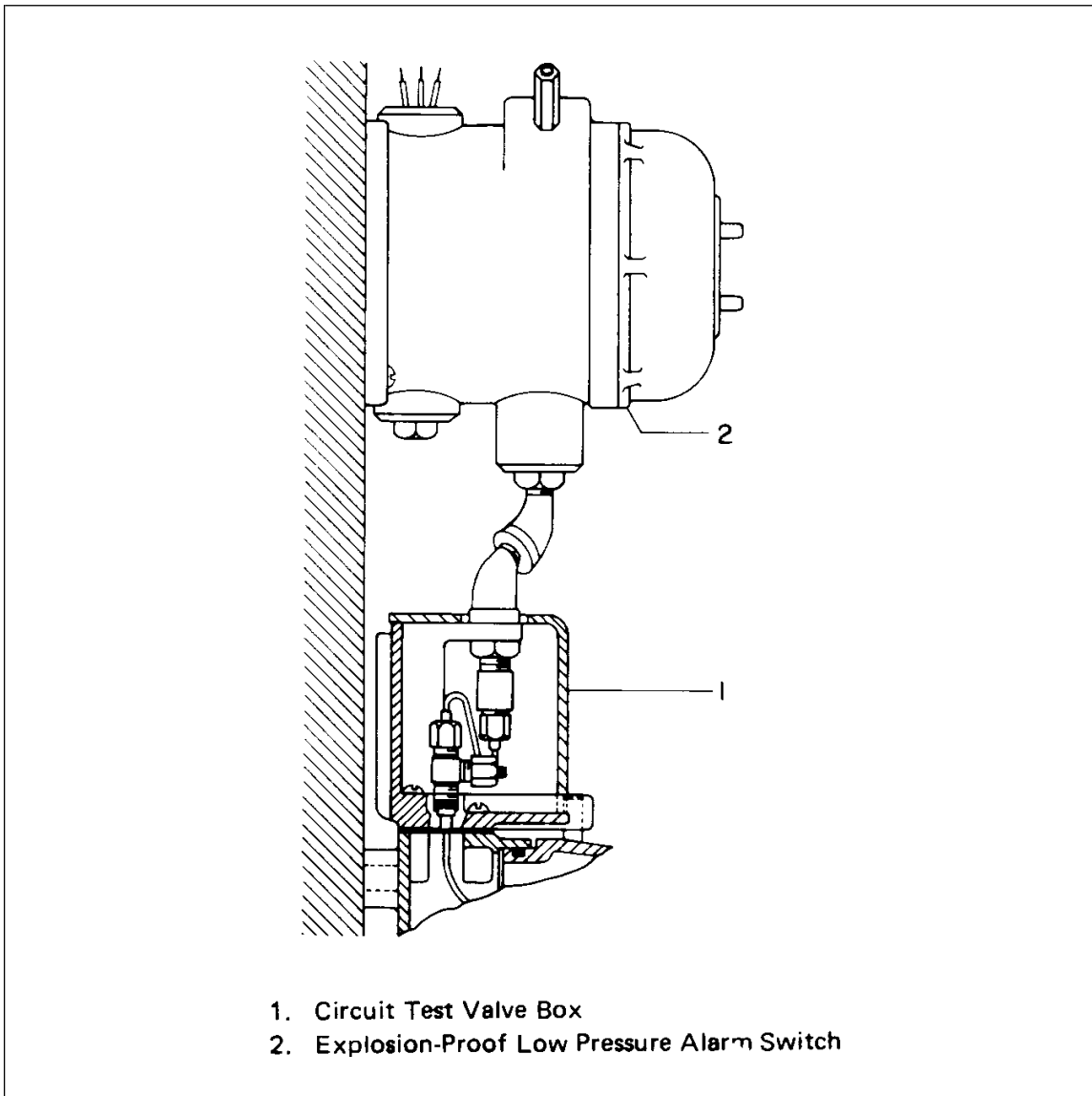

Fig. 190. Explosion-proof low pressure alarm switch.

The supervisory air panel (Fig. 194) is a self-contained unit consisting of an air pump, pressure switch, air dryer, air check valve, and connections for attachment to the Protomatic release.

A plant air or compressed nitrogen supervisory system consists of air dryer, pressure regulators, control valves, gauges, pipe, nipples, tubing, and fittings for connection to the Protomatic release.

The Protomatic system is specifically approved for use with Grinnell Multimatic valve, Model A-4 (18, Fig. 187), where automatic rate-of-temperature-rise actuation is desired.

INSTRUCTIONS FOR RESETTING

To Reset Protomatic Release After Automatic or Manual Pneumatic Operation.

1. Close the main water supply valve (9, Fig. 187) and the diaphragm chamber control valve.
2. Push the reset knob (11, Fig. 186) in and gently rotate clockwise until the reset knob (10, Fig. 186) slips into the slot in the face of the weight lever shaft end (7, Fig. 186). Engage the weight lever (12, Fig. 186) and the detent (6, Fig. 186) by continued clockwise rotation. As soon as resistance to rotation is felt, stop turning and pull the reset rod back to its normal position.

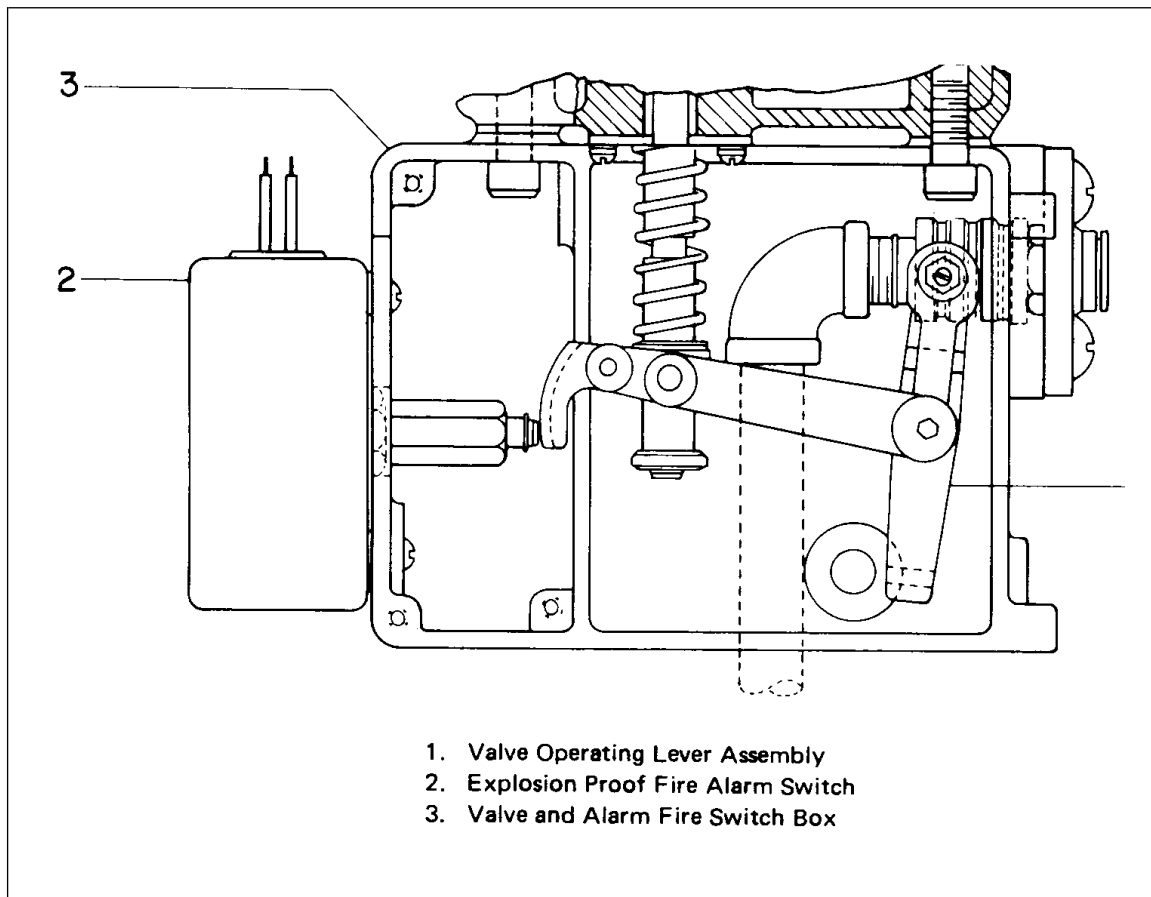

Fig. 192. Explosion-proof Fire Alarm Switch.

Note: Proper engagement of the weight lever and the detent is dependent upon supervisory air or nitrogen pressure being balanced in all pneumatic components of the release. When the reset rod is pulled back to its normal position, there will be an audible thud from the release if the weight lever and detent are not engaged. If this occurs, additional time must be allowed for the supervisory air or nitrogen pressure to equalize.

3. Remove the corner screw from the valve and alarm switch box cover (15, Fig. 186 and 15, Fig. 187) and open the cover.

4. Apply upward pressure to the valve tripping rod nut (9, Fig. 186 and 13, Fig. 189). As the valve tripping rod nut is raised, the valve tripping rod (10, Fig. 189) will lock in its service position.

5. Close the sleeve valve (9, Fig. 189) by pushing up on the pin (21, Fig. 186 and 14, Fig. 189) projecting from the valve operating lever assembly (8, Fig. 189).

6. Open the diaphragm chamber control valve (10, Fig. 187).

7. Inspect the sleeve valve and its drain connections for leaks. The sleeve valve must be watertight. Check the valve for obstructions by pushing down on the pin (21, Fig. 186) projecting from the valve operating lever while observing the drain connections. There must be a free flow of water through the drain.

Caution: If the sleeve valve leaks, check the valve operating lever to be sure it is in its uppermost position. If flow from the valve is obstructed, flush the valve by sudden opening after it has been closed long enough to permit a full buildup of pressure. If these measures fail, contact the nearest factory representative for assistance. Under no conditions should disassembly of the sleeve valve be attempted by other than fully qualified personnel.

8. Close the diaphragm chamber control valve (10, Fig. 187).

9. Close the sleeve valve (9, Fig. 189) as soon as water stops flowing from its drain connection.

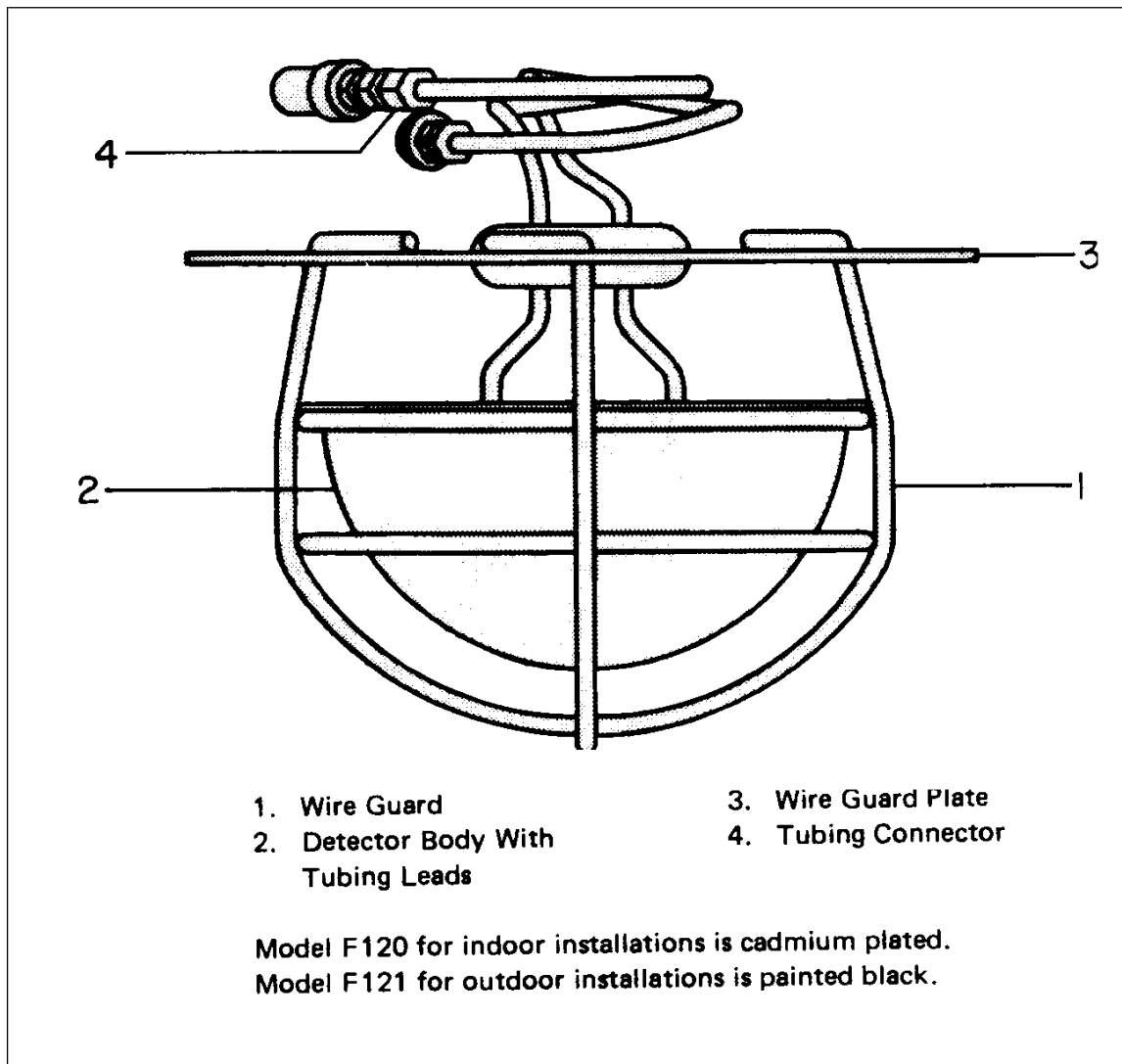

Fig. 192. Protomatic Detector.

10. Close the valve and alarm switch box cover (15, Fig. 186) and replace the corner screw.
11. If the release was actuated by operation of a manual pneumatic remote control, the remote control must be reset. Grinnell remote control stations are reset by pushing the operating lever up, closing the cover and inserting a new break rod through the small hole in the top of the enclosure assembly.
12. The Protomatic release is now set for service.
13. Reset the Multimatic valve according to **INSTRUCTIONS FOR RESETTING MULTIMATIC VALVE.**

Note: The "Shut Valve" tag procedure should be followed.

To Reset Protomatic Release After Manual Operation.

If actuation was by operation of a manual pull cable station or of the manual release (14, Fig. 187) on the front of the valve and alarm box cover, the Protomatic release should be reset as follows:

1. Close the main water supply valve (9, Fig. 187) and the diaphragm chamber control valve (10, Fig. 187).
2. Remove the corner screw from the valve and alarm switch box cover (15, Fig. 186 and 15, Fig. 187) and open the cover.

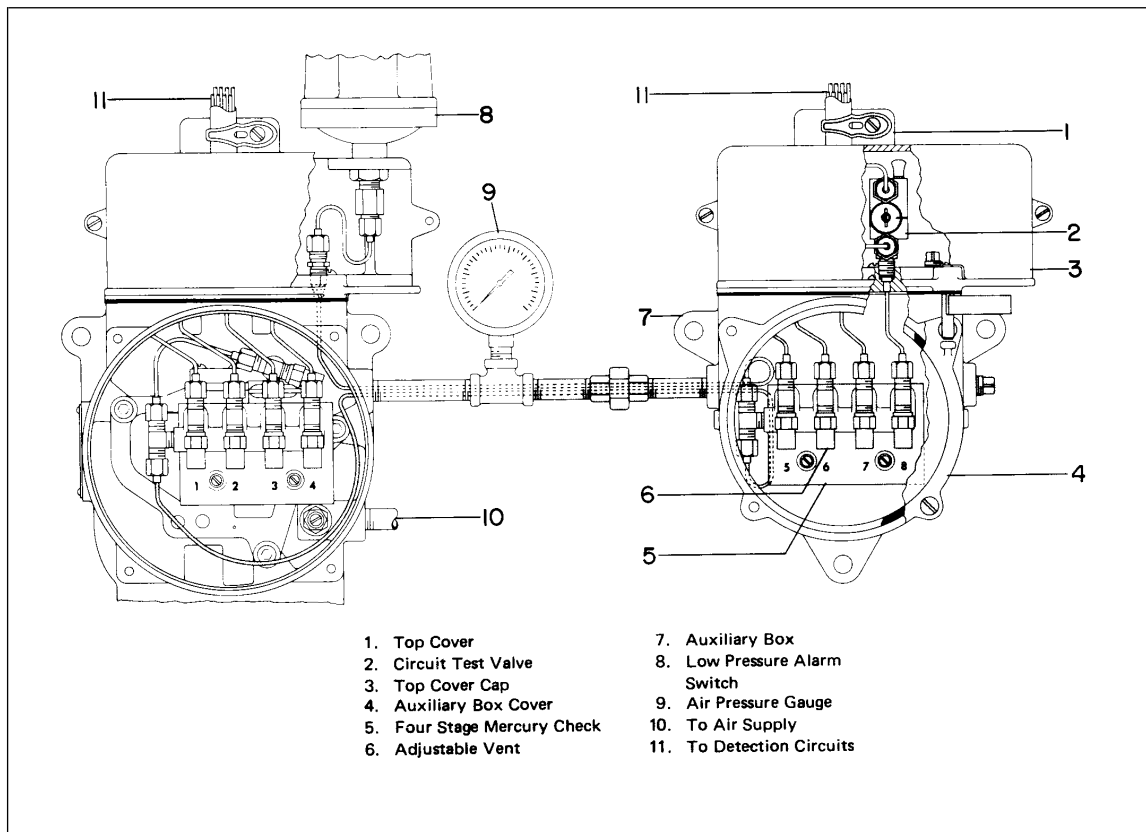

Fig. 193. Auxiliary Enclosure for Mercury Checks for Protomatic Release.

3. Close the sleeve valve (9, Fig. 189) by pushing up on the pin (21, Fig. 186) projecting from the valve operating lever assembly (8, Fig. 189).

4. Open the diaphragm chamber control valve (10, Fig. 187).

5. Inspect the sleeve valve and its drain connections for leaks. The sleeve valve must be watertight. Check the valve for obstructions by pushing down on the pin (21, Fig. 186) projecting from the valve operating lever while observing the drain connections. There must be a free flow of water through the drain.

Caution: If the sleeve valve leaks, check the valve operating lever to be sure it is in its uppermost position. If flow from the valve is obstructed, flush the valve by sudden opening after it has been closed long enough to permit a full buildup of pressure. If these measures fail, contact the nearest factory representative for assistance. Under no conditions should disassembly of the sleeve valve be attempted by other than fully qualified personnel.

6. Close the diaphragm chamber control valve (10, Fig. 187).

7. Close the sleeve valve (9, Fig. 189) as soon as water stops flowing from its drain connection.

8. Close the valve and alarm switch box cover (15, Fig. 186) and replace the corner screw.

9. If the release was actuated by operation of the manual release cover, close the cover and insert a new break rod (8, Fig. 186) through the small hole in the top of the cover.

10. The Protomatic release is now set for service.

11. Reset the Multimatic valve according to **INSTRUCTIONS FOR RESETTING MULTIMATIC VALVE.**

Note: The "Shut Valve" tag procedure should be followed.

Instructions for Resetting the Multimatic Valve.

1. Open main drain (6, Fig. 187) and allow system to drain.

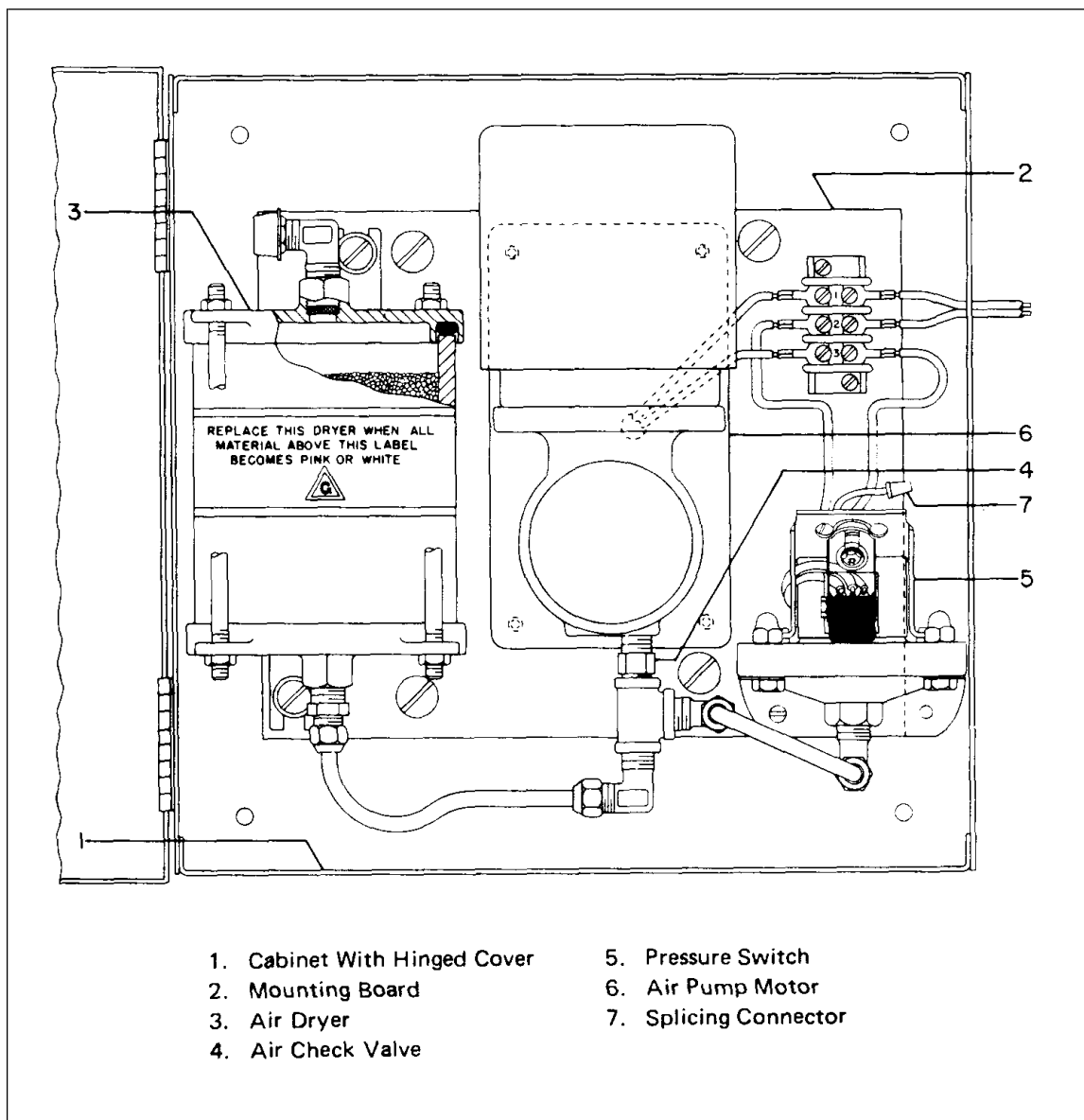

Fig. 194. Supervisory Air Panel, Model F111, for Protomatic Release.

2. Open auxiliary drain valves and plugs at low points in the system. Close when water ceases to drain.
 3. Depress the push rod of the ball drip valve (12, Fig. 187) to be sure it is open and that the Multimatic valve has drained.
 4. Remove hand-hole cover (19, Fig. 187) and carefully clean all interior parts. Make sure that the pressure equalizing vents (15, Fig. 198) in the clapper (11, Fig. 198) are open and that all parts are clean and free of scale. Test the clapper, clapper latch (10, Fig. 198), and the flange and push rod assembly (8, Fig. 198) for freedom of movement.
- CAUTION: NEVER APPLY GREASE OR ANY OILY SUSTANCE TO INTERIOR PARTS OF THE VALVE.**
5. Raise the clapper and move the clapper latch to the left sufficiently to allow the clapper to be resealed. Release the clapper latch so that its foot rests on the boss of the clapper.
 6. Open diaphragm chamber control valve (10, Fig. 187).

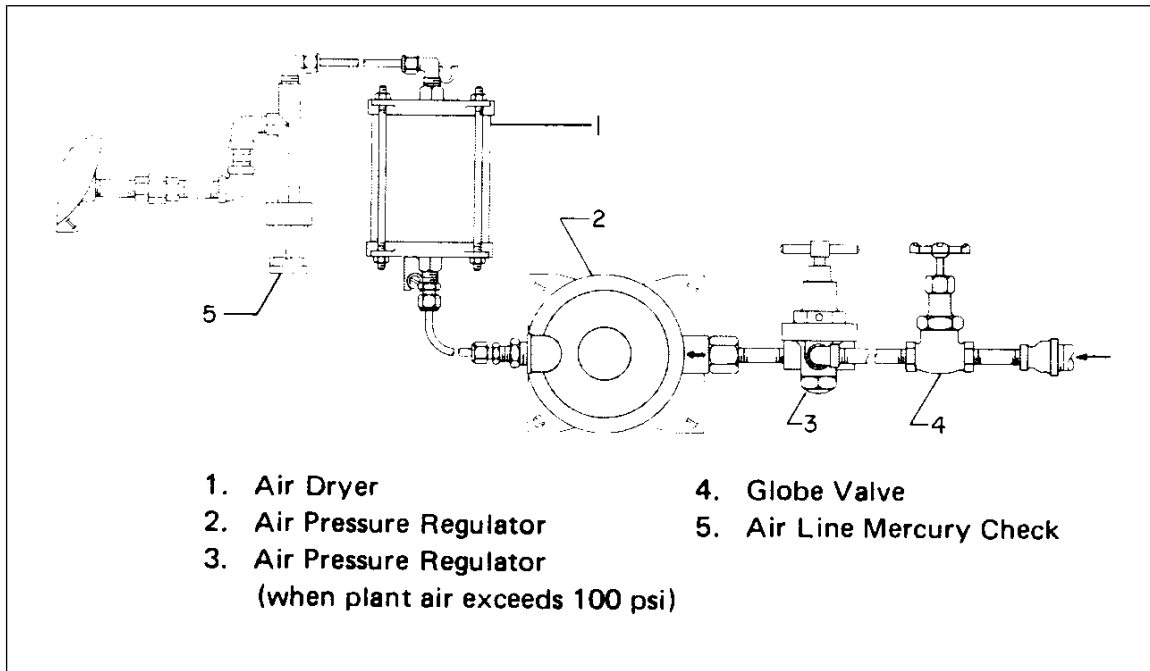

Fig. 195. Plant Air System for Protomatic Release

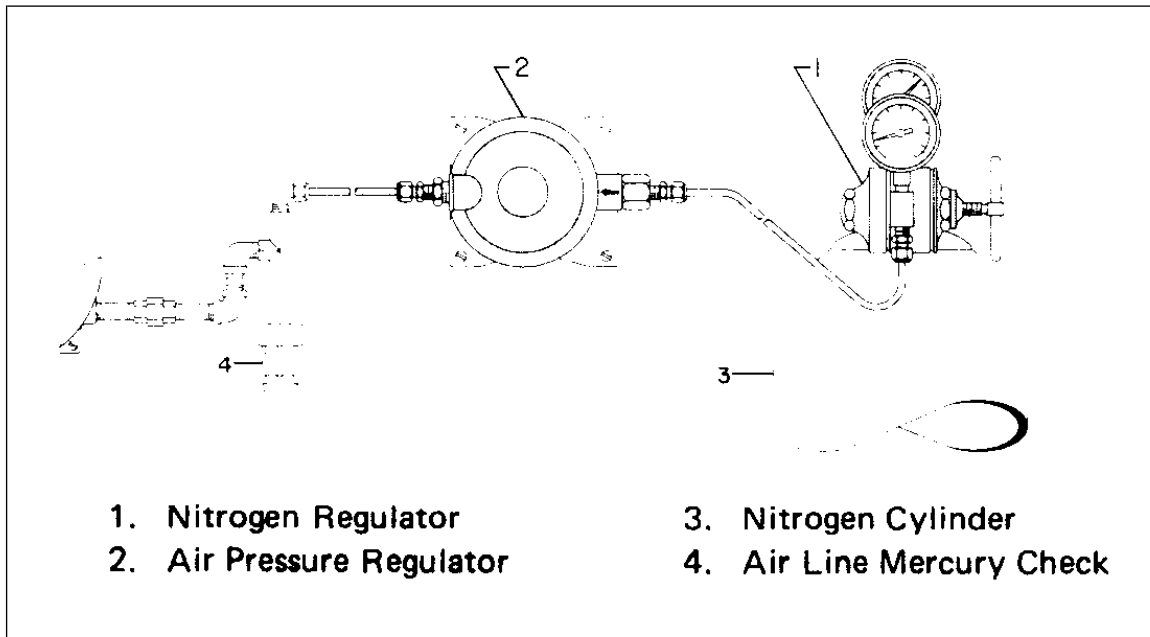

Fig. 196. Compressed Nitrogen System for Protomatic Release

7. Allow sufficient time for full pressure to buildup against the diaphragm (12, Fig. 198) through the diaphragm supply restriction (14, Fig. 198).

8. Replace the hand-hole cover (19, Fig. 187) on its gasket and tighten hand-hole cover nuts. Make sure the hole in the gasket is over the orifice in the face of the valve. Water will issue from this orifice if an attempt is made to open the main gate valve before the hand-hole cover is secured in place.

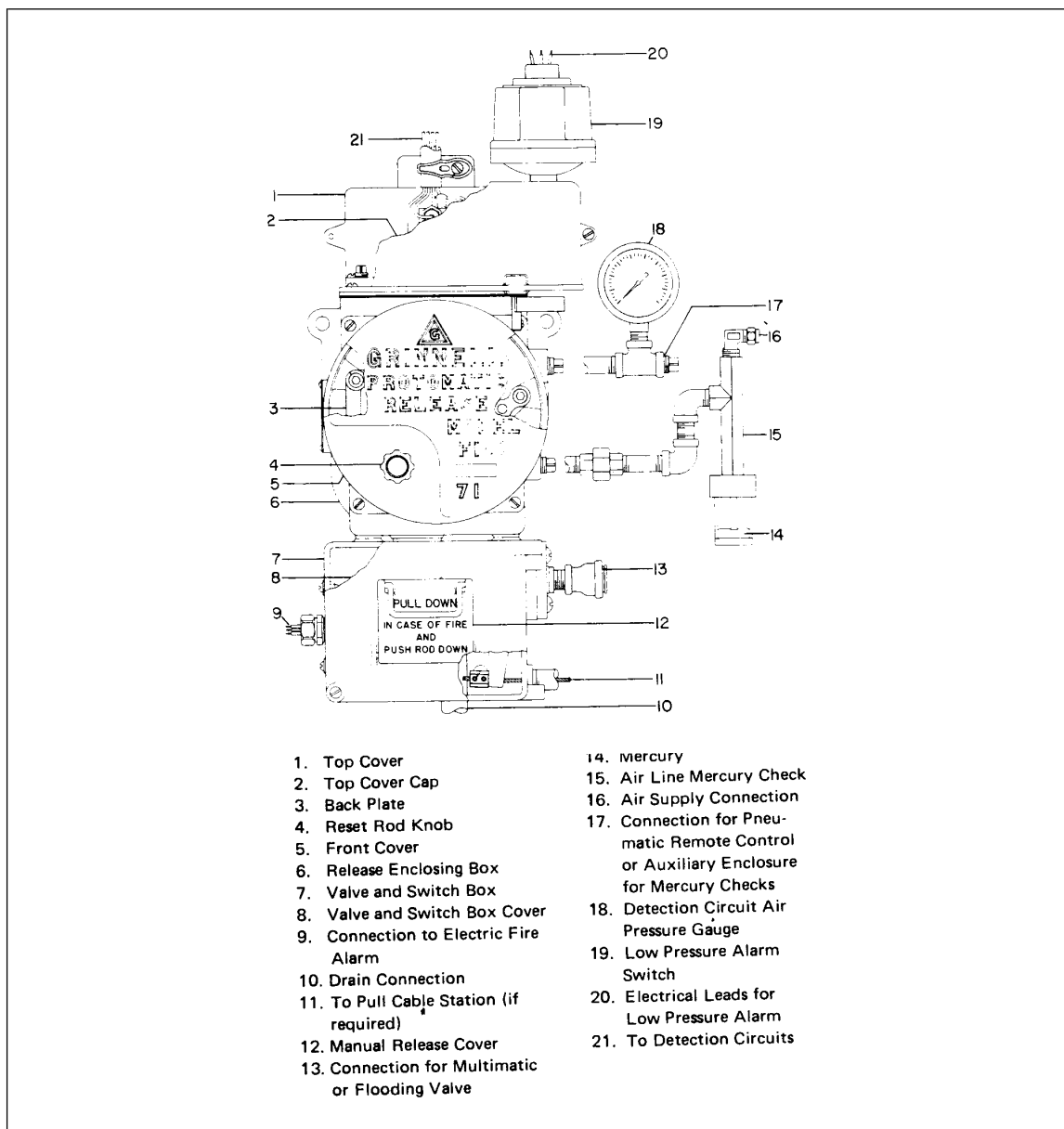

Fig. 197. Housing Components and Trimmings for Protomatic Release.

9. Slowly open the main water supply valve (9, Fig. 187), closing the main drain valve (6, Fig. 187) when water begins to flow from it. If water leaks past the ball drip valve (12, Fig. 187) into the drip funnel, the Multimatic valve is not seated tightly and must be reset. If there is no leakage, the Multimatic valve is seated tightly and the main water supply valve must be opened fully.

INSTRUCTIONS FOR INSPECTING THE PROTOMATIC RELEASE

Protomatic systems should be visually inspected and physically tested quarterly. The Protomatic release detection circuits and supervisory pressure system should be inspected for physical defects or other conditions that could affect operation of the system. Integrity of the detection circuits and response of the release should be tested. Dependability of the supervisory pressure and operation of the alarms should be verified.

Inspect the release and trimming for physical damage. Check the sleeve valve (9, Fig. 189) and drain connections for evidence of leaks. Rotate the reset rod knob (11, Fig. 186) to be sure the reset rod (10, Fig. 186) is free.

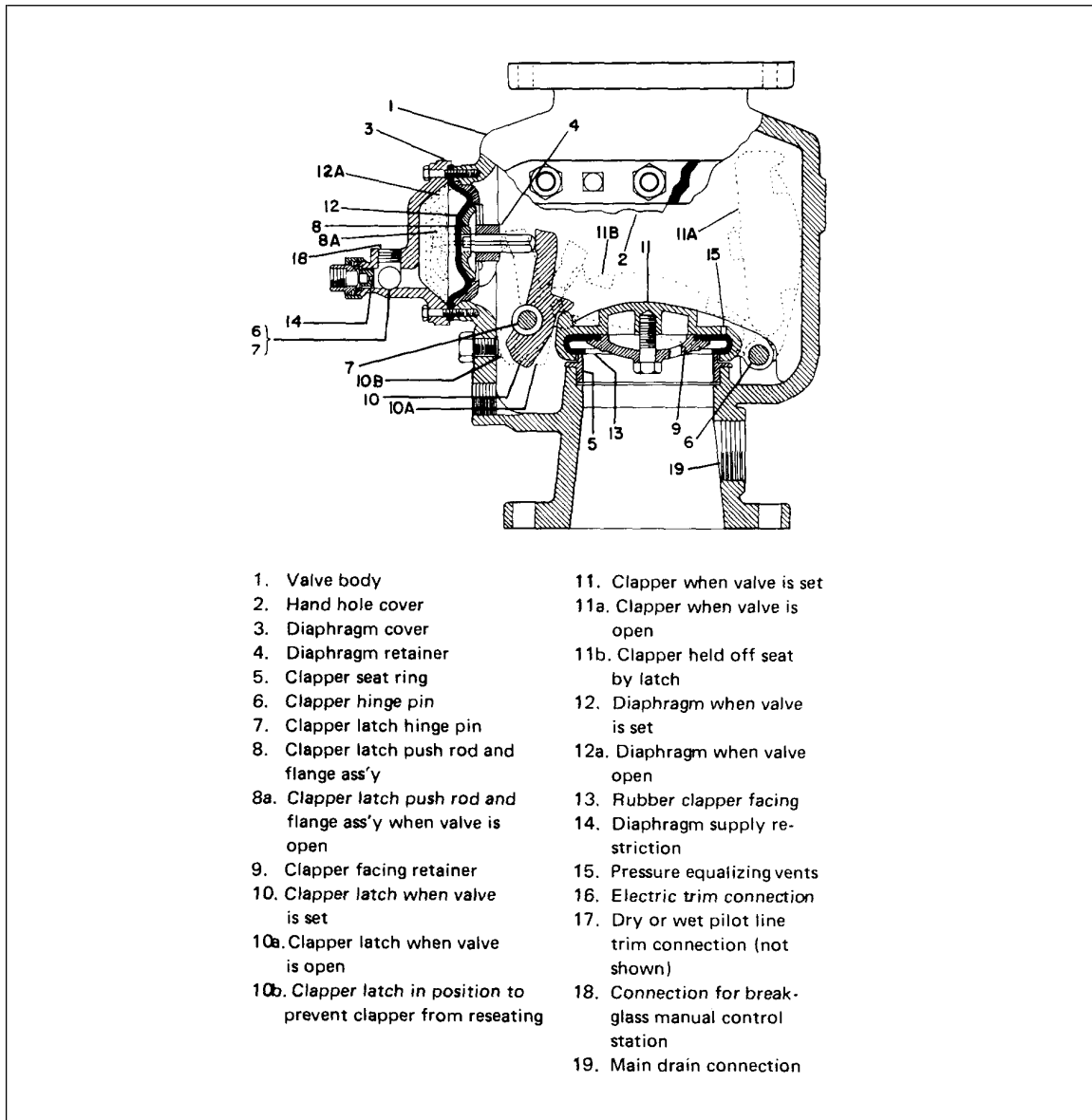

Fig. 198. Grinnell Multimatic Valve Model A-4.

The strap seal (4, Fig. 187) should be unbroken. Compare the serial number on the seal with the recorded serial number to be sure the front cover (4, Fig. 186) has not been tampered with.

Caution: Do not remove the front cover (4, Fig. 186) unless subsequent tests indicate operating deficiencies. If removal is necessary, it should be done only by fully qualified personnel.

Inspect all Protomatic detectors and exposed tubing for corrosion or mechanical damage. Be especially watchful for broken, pinched, or tightly looped tubing.

The source of supervisory pressure should be inspected to be sure it is in good condition and is operating properly. If nitrogen is used, the reading of the high pressure gauge should be recorded and compared with readings of previous inspections to determine if an abnormal loss of nitrogen has occurred.

Operation Tests. At quarterly inspections, response of the release and detection circuits should be tested and operation of the sleeve valve and alarms verified. **(To be done only by fully qualified personnel.)**

Release Response Test. Response capabilities of the release and detection circuits are verified by the *Standard Release Response Test* or the *Special Release Response Test*. **(To be done only by fully qualified personnel.)**

The Standard Release Response Test is for verification of the response capabilities of the Protomatic release and all Protomatic detection circuits except those outlined in (1) and (2) of the *Special Release Response Test*.

The Special Release Response Test is designed for verification of response capabilities of the Protomatic release with Protomatic detector circuits within the scope of either of the following conditions:

1. Protomatic detector circuits with 8-second circuit vents, 3.5 ounces per square inch release trip settings, and consisting of at least 600 but less than 800 feet of tubing with more than four detectors connected.
2. Protomatic detector circuits with 8-second circuit vents and 3.5 ounce per square inch release trip settings, and consisting of at least 800 but not over 1,000 feet of tubing with any number of detectors connected.

Sleeve Valve and Alarm Test. Operation of the sleeve valve and the electric fire alarm is verified by a common test procedure. Before conducting the test, proper notification must be given to the owner and to the fire department or central control station, if the alarm is so connected. Details of the test procedure are:

1. Close the main water supply valve (9, Fig. 187).
2. Open the main drain valve (6, Fig. 187).
3. Remove the corner screw from the valve and alarm switch box cover (15, Fig. 186) and open the cover.
4. Open the sleeve valve (9, Fig. 189) by pushing down on the pin (21, Fig. 186) projecting from the valve operating lever. Water should flow unobstructed from the drain connection (16, Fig. 187) of the sleeve valve and the fire alarm should sound.
5. Close the sleeve valve (9, Fig. 189) by pushing up on the pin (21, Fig. 186) projecting from the valve operating lever. Water should stop flowing from the drain connections and the alarm should be silenced.

Caution: If the sleeve valve leaks, check the valve operating lever to be sure it is in its uppermost position. If flow from the valve is obstructed, flush the valve by sudden opening after it has been closed long enough to permit a full buildup of pressure. If these measures fail, contact the nearest factory representative for assistance. Under no conditions should disassembly of the sleeve valve be attempted by other than fully qualified personnel.

6. Close the valve and switch box cover (15, Fig. 186) and replace the corner screw.
7. Close the main drain valve (6, Fig. 187).
8. Open the main water supply valve (9, Fig. 187) fully.

Note: The "Shut Valve" tag procedure should be followed.

4.8 Hodgman Model A

Hodgman Model A Water Control Valve 3-INCH 1963-1969 6-INCH 1969

Hodgman Manufacturing Co., Taunton, Massachusetts

DESCRIPTION

The Model A Hodgman water control valve (Fig. 199) is a differential type valve, designed to control the flow of water to open sprinklers, spray nozzles, or mechanical foam-making equipment.

This differential-type water control valve has two clappers (D and G), at right angles to each other and connected by an arm so that they function as a unit. The water seat clapper (D) holds back the water supply. A ball stud universal joint (E) connects it to the arm (N) so that it will seat tightly. The pressure chamber clapper (G) separates the pressure chamber formed by the handhole cover (B) from the upper part of the valve body (A) which is part of the open head sprinkler system. Clapper (G) has a rubber seat (I) which forms a seal with pressure chamber water seat ring (H).

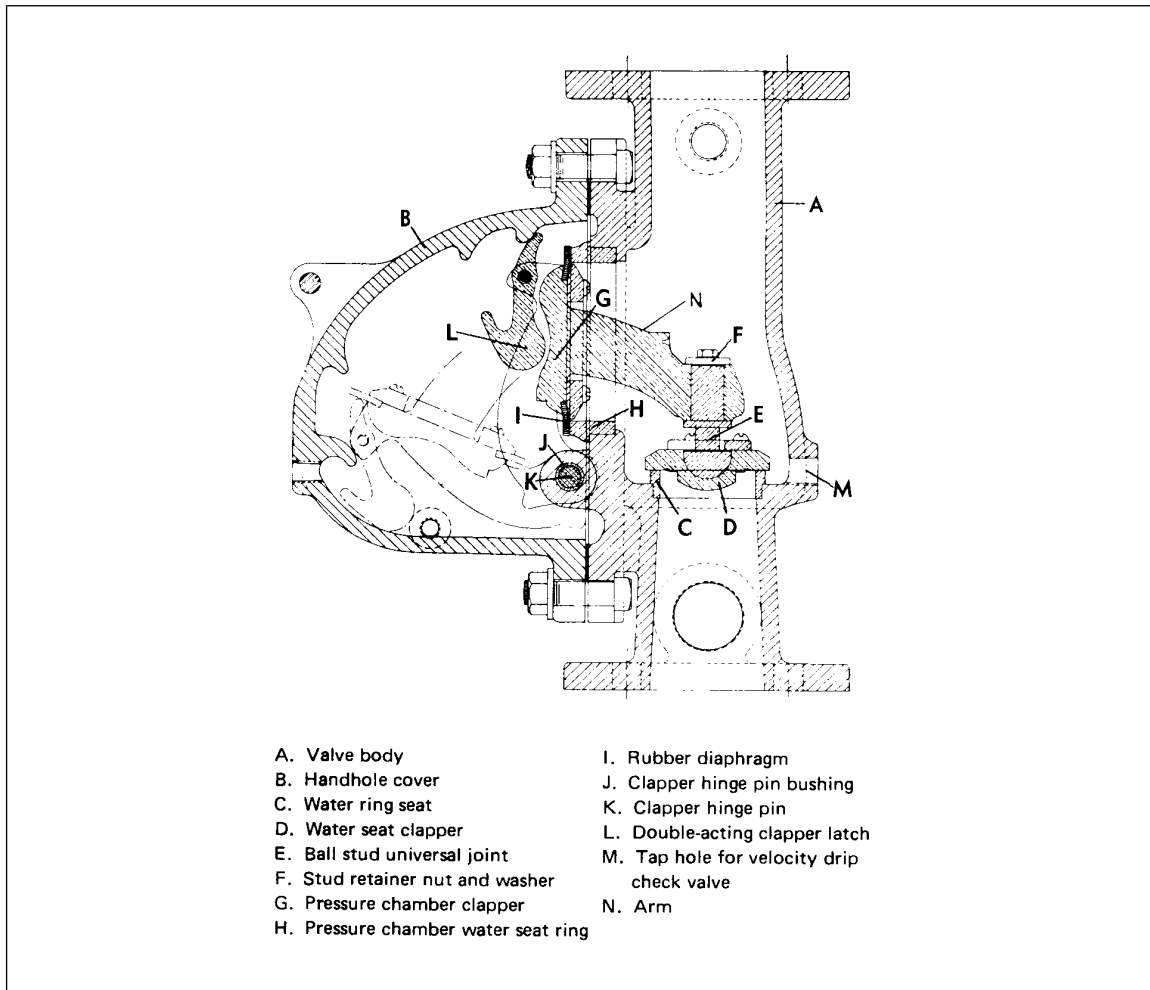

Fig. 199. Hodgman Model A deluge valve.

Under normal set conditions, the chamber formed by clapper (G) and cover (B) is filled with water having the same pressure as the main water supply under water clapper (D). The water is supplied through a 1/2-inch priming line from beneath the manual water control valve. The priming line to the pressure chamber is equipped with a priming cock, a 'Y' strainer and a restriction orifice (6, 7 and 8 in Fig. 201). After the deluge valve is set, the priming cock (6, in Fig. 201) is closed and water is then automatically supplied to the pressure chamber through a line from below the water clapper D (Fig. 199). This line connects to the priming line between the priming cock (6, in Fig. 201) and the 'Y' strainer (7, in Fig. 201). A check valve (13, in Fig. 201) in the line prevents inadvertent operation of the deluge valve if there is a drop in the main water supply pressure.

OPERATION OF DELUGE VALVE

Refer to Figure 199.

In normal set condition, equal water pressure is maintained in the pressure chamber and below the water clapper in the deluge valve. When water or air is released from the pilot line by the operation of either a sprinkler head, emergency trip valve, or a detector release, the actuator exhausts the water pressure in the pressure chamber of the deluge valve. When the water is released in this pressure chamber faster than it can be replaced through the inlet orifice, the deluge valve will trip and allow water to flow to the extinguishing system of open sprinkler heads. Water also enters the pipe line leading to a pressure switch and/or motor gong. The water clapper D is held in an open position by the double-acting clapper latch.

EMPTYING AND CLEANING

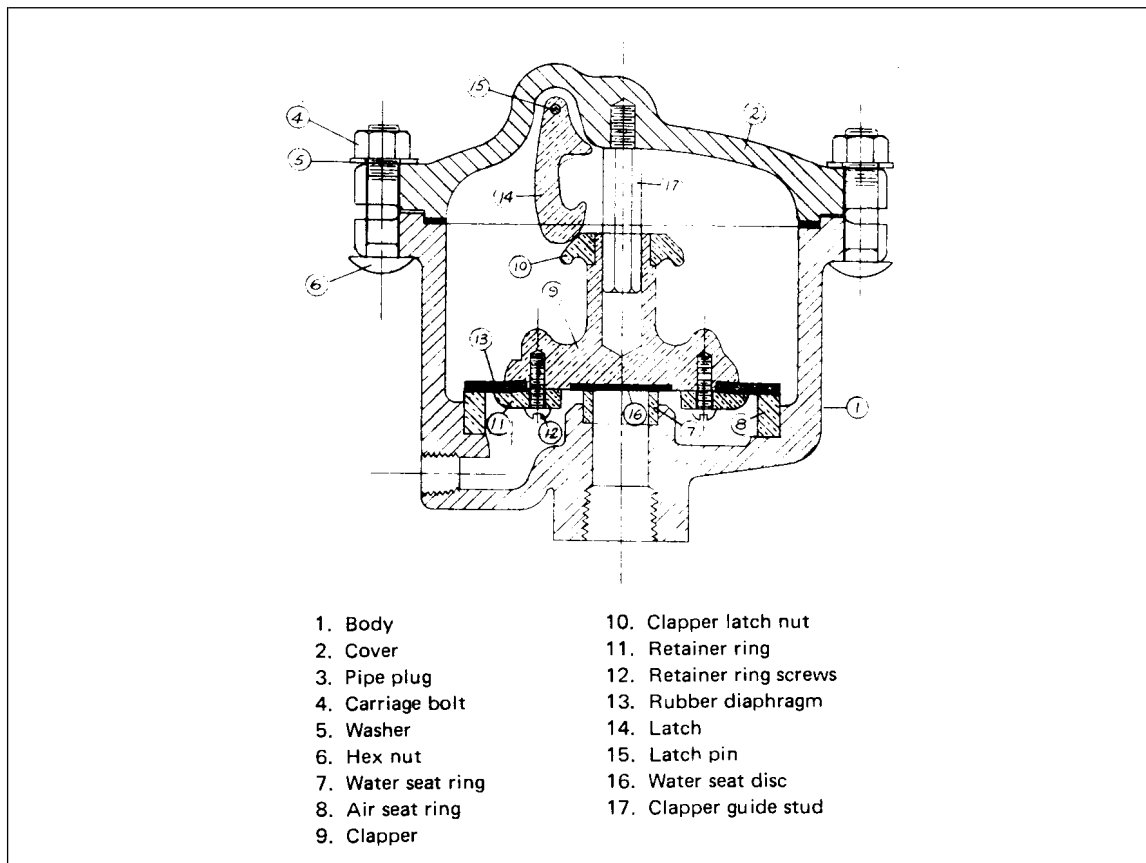

Fig. 200. Model A pilot line actuator.

Refer to Figure 199.

Close main gate valve in supply line. Open wide drain valve (15, in Fig. 201) and remove handhole cover plate B (Fig. 199). Remove clapper assembly by holding it in one hand and taking hinge pin K completely out. With cleaning cloth carefully wipe off the surface of the rubber seat I, water seat clapper D, water ring seat C, pressure chamber and pressure chamber water seat ring H. Replace clapper assembly with clapper hinge pin K and push clapper assembly forward to the seat rings so that it is in a closed position.

RESTORING DELUGE SYSTEM TO SERVICE

1. Reset detector release. See section titled **RESTORATION OF DETECTOR RELEASE DEVICES.**
2. Reset actuator. See sections titled **PILOT LINE ACTUATOR** and **Cleaning and Resetting Actuator.**
3. Reset deluge valve (Fig. 201) as follows:
 - (a). Open priming stop cock (6). Water is admitted through restriction unit (8) to the pressure chamber and pilot line.
 - (b). Partially open emergency trip valve (5) until water flows from the ball drip valve (13); then close emergency trip valve (5). This eliminates air pockets from the pressure chamber. Pressure on gauges (9 & 10) should read the same.
 - (c). Close main drain valve (15) and then reopen two full turns.
 - (d). Crack open supply gate valve; then close drain valve (15). If there is no leakage into the drip cup (18), fully open water supply gate valve.
 - (e). Close priming stop cock (6) tight. Deluge valve is now reset and system restored.

Note: If a failure in water pressure or water supply occurs, check valve (19) and the closed priming cock (6) would retain pressure in the pressure chamber, preventing operation of the deluge valve.

PILOT LINE ACTUATOR

Description. A Hodgman Model A pilot line actuator (Fig. 200) is used with the Hodgman Model B deluge valve on installations where automatic fixed temperature operation is desired. The pilot line of sprinklers contains air if exposed to freezing temperatures. The actuator is basically a differential-type valve that is in a normally closed position. It consists of an upper and lower chamber separated by a bronze clapper (9). The rubber seat (13) is secured to the clapper by a retaining ring (11), and the water seat disc (16) is bonded to clapper (9). A clapper guide stud (17) is threaded into the cover. Also attached to the cover by a pin is the clapper latch (14).

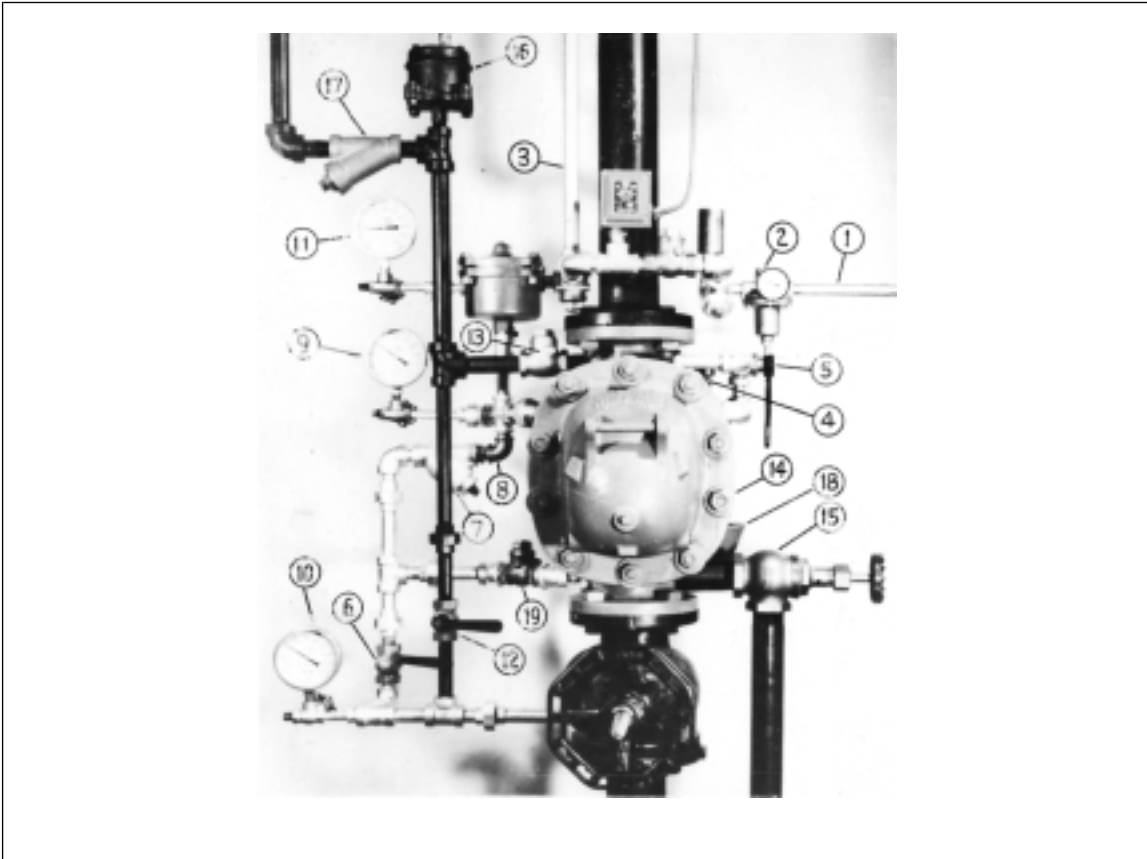

Fig. 201. Deluge valve installation, showing trimmings.

Operation. When the clapper is on its seat, a small amount of priming water is provided to assure a more positive seal at the air seat ring. Pilot line pressure acting downward on the larger surface of the clapper overcomes water supply pressure acting upwards at the small area in the center of the clapper. The fusing of one or more sprinklers in the dry or wet pilot line reduces pressure in the upper chamber to the point where water supply pressure overcomes the downward force, and the clapper moves upwards on a guide stud (17) and is held open by a latch (14). The movement of the clapper seat allows water supply pressure in the enclosed chamber of the deluge valve to escape to atmosphere, thus operating the deluge valve. A restriction orifice in the deluge valve trim line, supplying the enclosed chamber of the actuator and the pilot line, assures positive action of the actuator.

Cleaning and Resetting. Remove nuts and bolts and raise cover of actuator (Fig. 200) slightly. With one hand reach under cover (2) and disengage clapper latch (14) from clapper (9). Lift off cover completely and remove clapper. With a clean cloth wipe diaphragm and water seats clean. Replace clapper on seat and pour in priming water sufficient to cover rubber seat (13) of valve. Replace cover with clapper guide (17) centered in guide hole of clapper, and bolt tightly in place.

RATE-OF-RISE AND FIXED-TEMPERATURE THERMOSTATIC RELEASE MODEL 68 DETECTOR

The Hodgman Model 68 Detector Device is a combination fire detector and release device (Fig. 202). It operates on both the rate-of-rise and fixed-temperature principles. The detectors are intended for installation within a building at ceiling level. The detectors are interconnected by a pilot line piping system connected to a Hodgman Model A actuator (for dry pilot lines) and Model A automatic operated water control (deluge) valve.

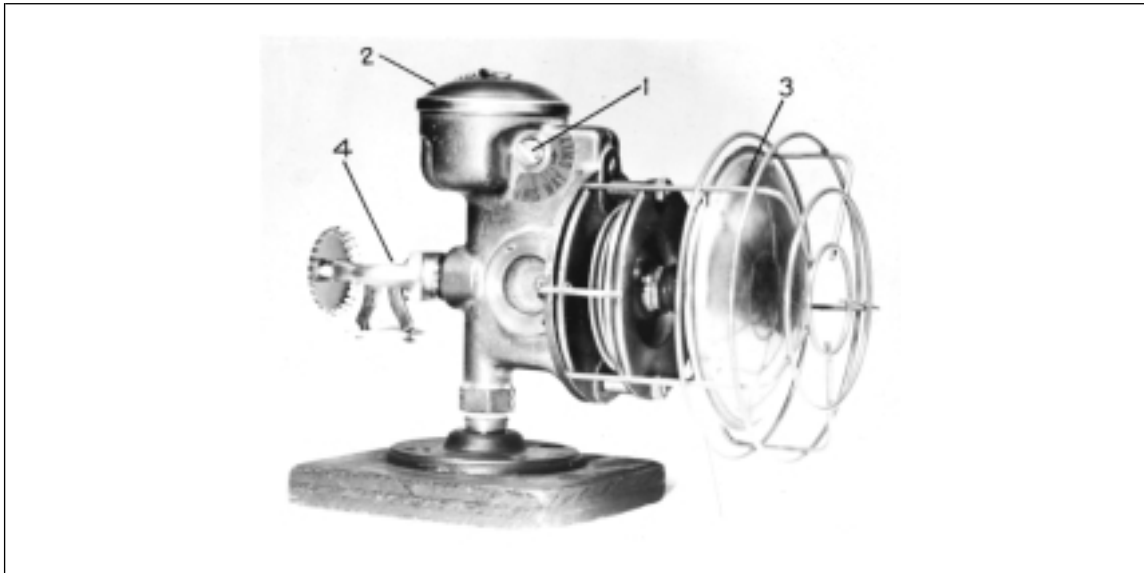

Fig. 202. Model 68 thermostatic release detector.

1. The Model 6 detector-release, when heat operated, relieves the pilot line pressure. It has a combination rate-of-rise and fixed-temperature heat-responsive device with a built-in valve. The valve is piped to the air or water pilot line system of an actuator or water deluge valve. The detector is rated to handle 40 psig air or 150 psig water pressure.

2. The detector's valve operates when a heat collector is exposed to a fire condition producing a temperature rise of at least 15°F per minute or exceeds the temperature rating of an automatic sprinkler head which acts as the fixed temperature operating element.

Operation.

General.

1. The detector is selected with a proper vent orifice to compensate for normal ambient temperature changes. Similarly, the sprinkler head temperature is selected to suit the location.
2. With a detector installed in the pilot pipe line of a system, the reset latch level pin (1) is turned which latches the valve cap assembly onto its seat. The pilot line is then pressurized with either air or water.

Alarm Condition.

1. A fire, producing a rate of temperature rise which exceeds the pressure venting rate of the detector orifice, causes the bellows (3) to expand. Its attached push rod forces the linkage to pivot and rotate, causing the reset latch to disengage. The hinged valve cap assembly rotates free and releases the pressurized air or water in the pilot line and blows the cover cap (2) to one side. This reduction of pressure causes the deluge valve to operate.

2. If the sprinkler head (4) fuses first, the pilot line air or water is released through the sprinkler orifice.

Restoration of Detector Release Devices. All detector release units that operate during a fire should be tested with the following procedure. Refer to Fig. 202.

1. Close main water supply valve to deluge valve.
2. Replace sprinkler head (4) in all operated release units.

3. Restore all detectors by turning the latch reset pin (1) with a screw driver $\frac{1}{4}$ turn. This will hold the valve cap assembly with rubber seat closed, i.e. on the vertical passageway from pilot line.
4. Position dust cover (2) on all release bodies.
5. If pilot line is dry, pressurize pilot line to operating pressure. If pilot line is wet, fill pilot line with air. (If an air line is not available, a small portable air compressor may be used to fill the pilot line.)
6. Hold heat source near heat collector chamber (3) of each release unit until release operates with the dust cover cap (2) being blown off the top of release body. This indicates that the soldered joints around the heat chamber have not failed and release unit is undamaged.
7. If a release unit fails to operate or has had a sprinkler head (4) with a rating of 286°F operate, the entire release unit must be replaced with a new unit.

4.9 Reliable Model B (Supertrol)

Deluge and Preaction Sprinkler Systems

RELIABLE MODEL B DELUGE VALVE MODEL A DRY PILOT LINE ACTUATOR SUPERTROL DELUGE AND PREACTION SYSTEMS

Reliable Automatic Sprinkler Co., Mt. Vernon, N. Y.

INTRODUCTION

The Reliable Model B deluge valve (Fig. 203) is used to control the flow of water to special extinguishing systems of open sprinklers, spray nozzles, or mechanical foam-making equipment.

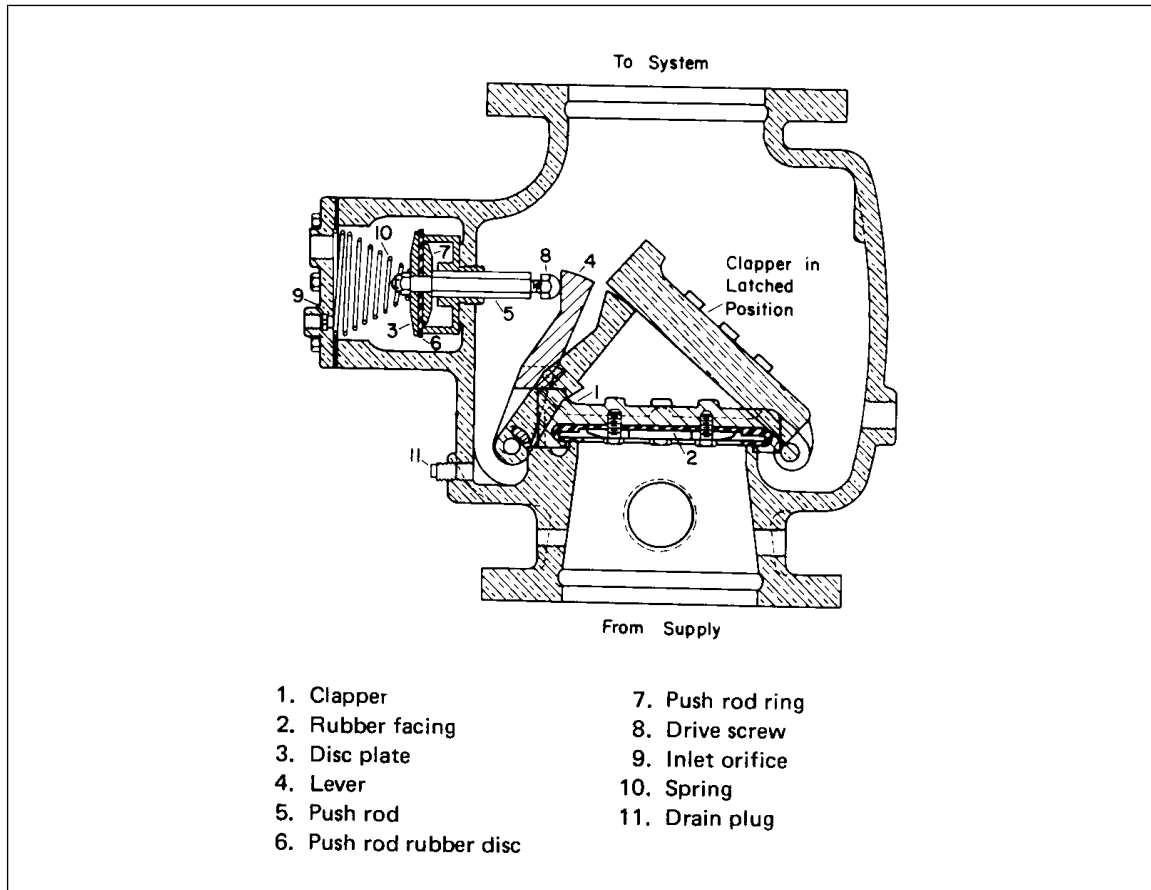

Fig. 203. Reliable Model B deluge valve.

Under normal conditions, clapper 1 is held closed by water pressure acting on disc plate 3 within a chamber (differential unit). Water pressure is admitted to the push rod chamber through a 1/8-in. inlet orifice 9, in a line from below the main supply valve. Whenever water pressure in this chamber is released to atmosphere faster than it can be supplied through the 1/8-in. orifice, the deluge valve will trip. Release of pressure from this chamber may be accomplished by any one of the following methods.

1. **Automatic.** Operation of one or more closed sprinklers in the wet or dry pilot line.
2. **Manual.** Opening of one or more manually operated valves arranged for remote or local operation of the deluge valve.

The Model A actuator permits a dry pilot line to be installed in locations subject to freezing temperatures. Release of pressure from the pilot line moves the actuator diaphragm to open a port and release the pressure from the push rod chamber of the deluge valve. The dry pilot line may be pressurized with air or nitrogen.

DESCRIPTION

Model B Deluge Valve

In the Model B deluge valve (Fig. 203), water supply pressure acts on disc plate 3 to transmit a force through push rod 5 to lever 4. Sufficient force is then created to keep clapper 1 closed.

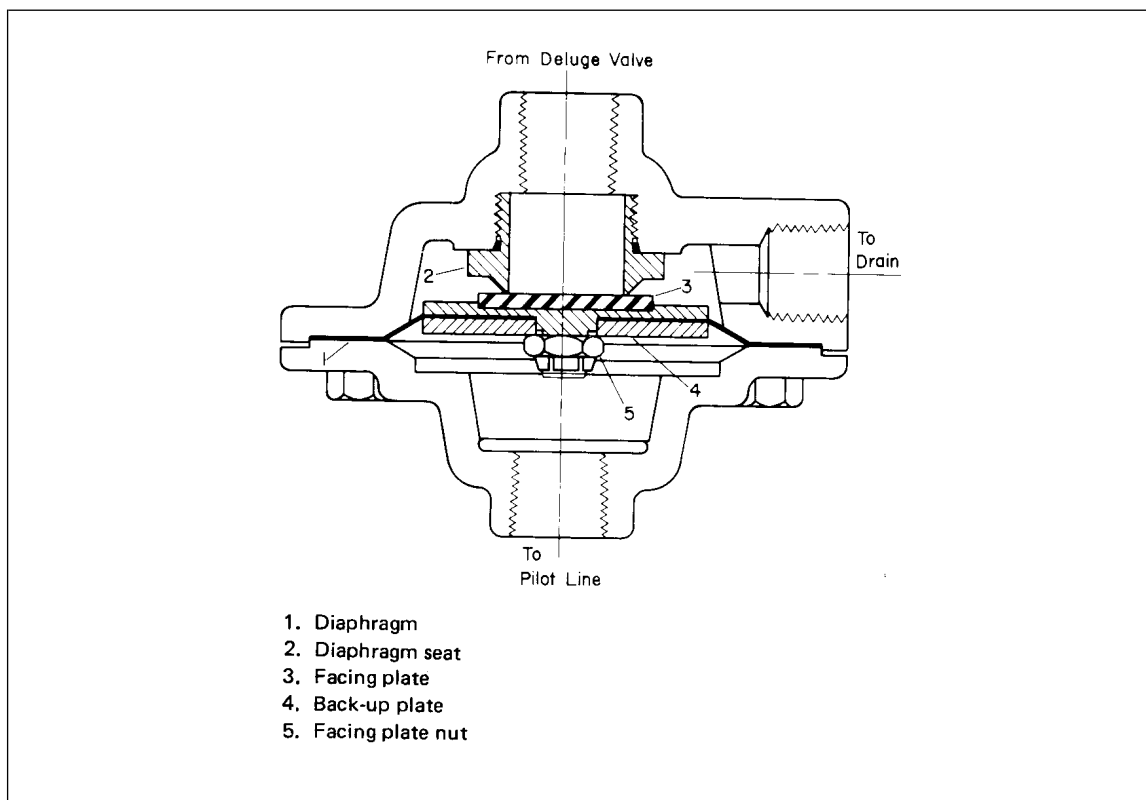

Fig. 204. Reliable Model A dry pilot line actuator.

Model A Actuator

The Model A actuator (fig. 204, 205) is a rubber-diaphragmoperated valve used to separate water pressure, used in the deluge valve, from the air or nitrogen pressure in the dry pilot line.

Model 2000 Control Panel

Three different Model 2000 control panels may be used with the Supertrol System. These are: (1) one-zone system panel; (2) two-zone system for protection of two separate areas; and (3) cross zoning in a single area. Operation of a (smoke) detector in either zone results in a prealarm signal only; the deluge valve is not opened by the solenoid release until at least one detector in each zone operates.

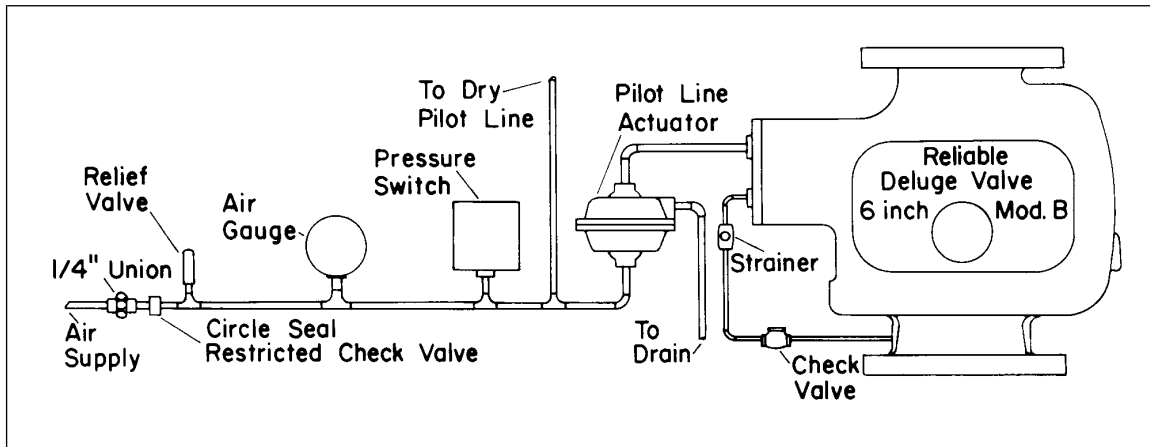

Fig. 205. Pilot line set-up (air).

Pilot Line Pressure Supply

Pressure supplied to the pilot line of sprinklers can be from either a nitrogen cylinder, a shop air system, or an automatically controlled compressor.

Nitrogen Cylinder. When the pressure supply is a cylinder (Fig. 206), nitrogen pressure is controlled by a twostage gas regulator manufactured by Airco Welding Products, Style No. 8069402. Maximum nitrogen pressure within the pilot line is controlled by a relief valve set at 40 psig. The 1/16-in. restricted check valve limits the nitrogen supply to assure reliable operation of the actuator.

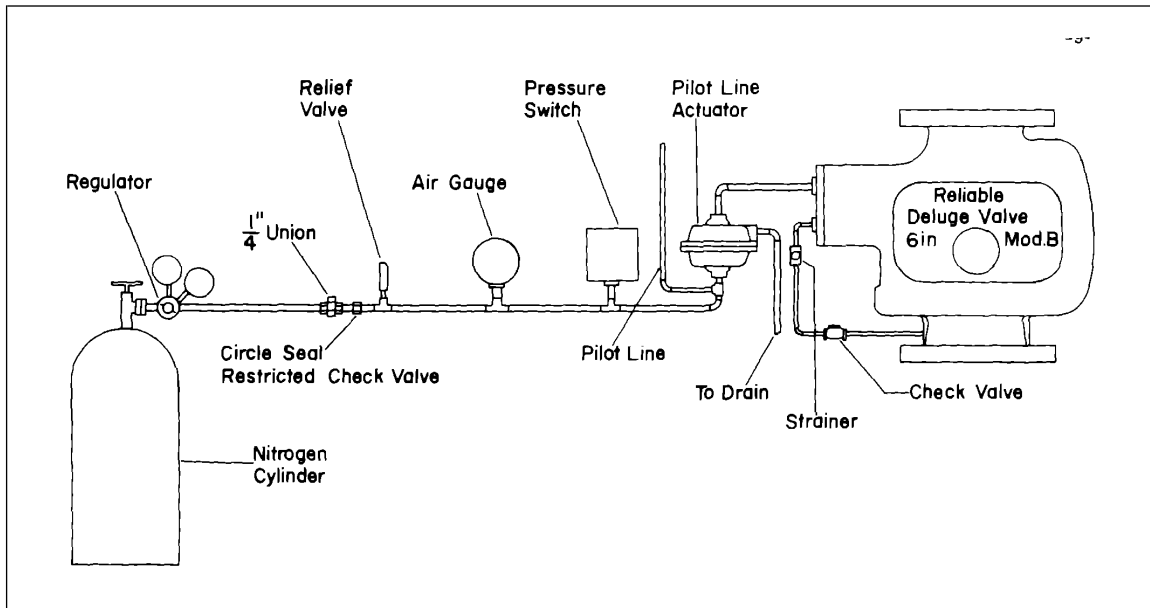

Fig. 206. Pilot line set-up (nitrogen).

Shop Air or Compressor. Fig. 205 shows the arrangement of components for shop air compressor tie-in. A 1/16-in. orifice limits the air supply to assure reliable operation of the actuator. A pressure switch is provided to give a low pressure alarm when the pressure in the pilot line drops to 25 psi.

OPERATION

Deluge Valve

When system pressure is released, either manually or automatically, water pressure on disc plate 3 (Fig. 203) is vented faster than it can be replaced through the 1/8-in. supply restriction orifice. Pressure in the push rod chamber is reduced sufficiently to allow supply pressure to force clapper 1 open. Clapper 1 is then out of the waterway or held open by lever 4.

Model A Actuator

Loss of pressure in the pilot line (by operation of a pilot line sprinkler) causes the diaphragm 1 and facing plate 3 to open (Fig. 204). This allows water from the deluge valve diaphragm chamber to be released through the drain in the actuator. The deluge valve operates as outlined in the preceding paragraph.

SETTING

Deluge Valve with Wet Pilot Line

Refer to Figures 1 and 5.

1. Close the main control valve supplying the water to the system.
2. Open main drain valve A.
3. Open all drain valves and vents at low points throughout the system, closing them when water ceases to flow.
4. Open drain valve E (Fig. 207) and drain water from the diaphragm chamber.

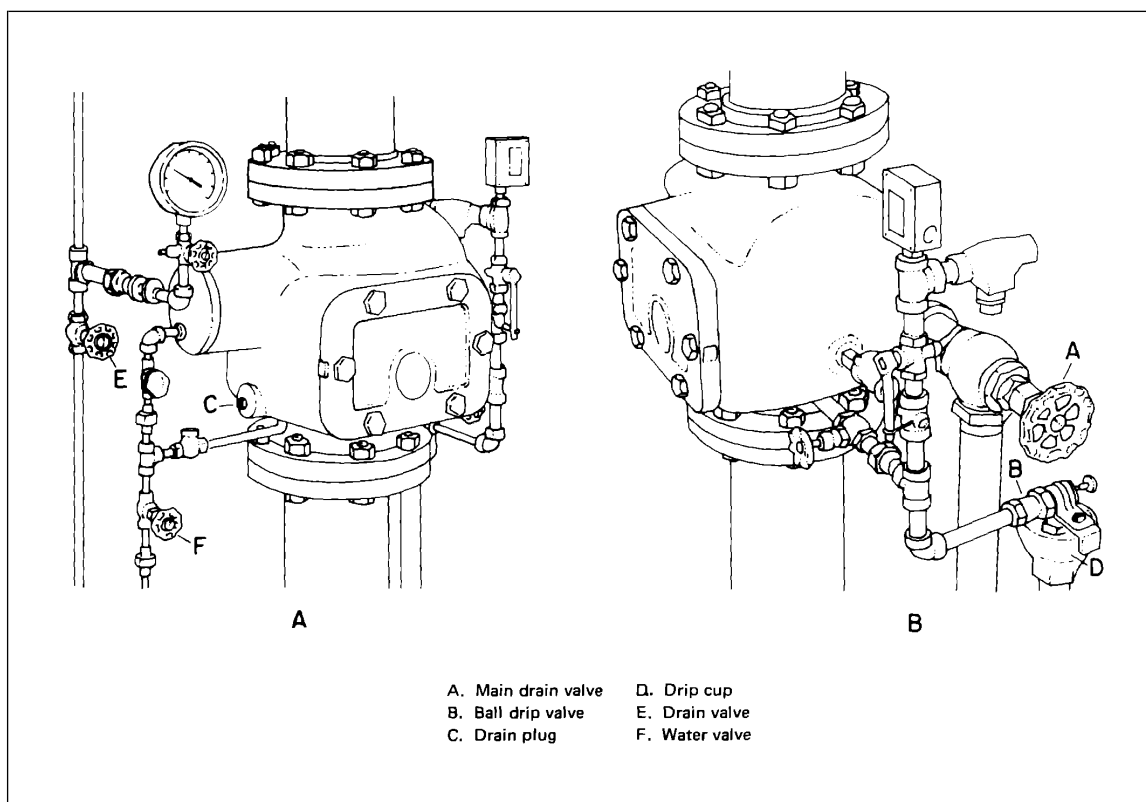

Fig. 207. Deluge valve with Model A actuator, basic trim.

5. Push in the plunger of the ball drip valve to force the ball from its seat.
6. Remove drain plug 11 (Fig. 203) (C, Fig. 207) and drain the body of deluge valve. Replace the plug securely when water ceases to flow.
7. Remove cover and raise clapper 1 to its open position.
8. Carefully clean rubber facing 2, clapper 1, and the seating surface.

9. Push lever 4 to the left and lower clapper 1.
10. Replace cover and tighten bolts.
11. Open water valve F (Fig. 207) and allow water to fill the push rod chamber. Close drain valve E and bleed the wet pilot line to remove all air from the system.
12. Open the main control valve slightly and close main drain valve A (Fig. 207) when water flows from it. Observe if water leaks through ball drip valve B into drip cup D. If no leak occurs, the water seat is tight.
13. **Open wide the main control valve.**
14. Close water valve F.

Deluge Valve with Model A Actuator

Refer to Figure 207, deluge valve with basic trim, and Figure 208, deluge valve with actuator trim.

1. Perform the preceding steps 1 through 10 of the setting procedure with basic trim.
2. Open water valve F and allow water to fill the push rod chamber and flow through pilot line actuator.
3. Pump air pressure into the dry pilot line as given in Table 27.

Table 27. Air Pressure For Dry Pilot Line

Maximum Water Pressure,			Air Pressure to be Pumped into Dry Pilot Line					
			Not Less Than			Not More Than		
psi	(kPa)	(b)	psi	(kPa)	(b)	psi	(kPa)	(b)
50	(345)	(3.5)	15	(103)	(1.0)	25	(172)	(1.7)
75	(517)	(5.2)	20	(139)	(1.4)	30	(207)	(2.1)
100	(689)	(6.9)	25	(172)	(1.7)	35	(241)	(2.4)
125	(862)	(8.6)	30	(207)	(2.1)	45	(310)	(3.1)
150	(1034)	(10.3)	35	(241)	(2.4)	50	(345)	(3.5)

4. Slightly open the main control valve, closing main drain valve A when water flows.
5. Observe if water leaks pass ball drip valve B into drip cup D. If no leak occurs, the water seat is tight.
6. Slowly **open wide the main control valve.**
7. Close water valve F.

TESTING

Model A Actuator Without Operating Deluge Valve

1. Close the main control valve.
2. Open water valve F (Fig. 207).
3. Decrease pressure on the dry pilot line until the pilot line actuator operates. This will be indicated by a sudden drop of water pressure in the deluge valve.
4. To reset, increase pressure in the dry pilot line as given in Step 3 in the preceding section on resetting the deluge valve with actuator.
5. Open slightly the main control valve, closing the main drain when water flows.
6. Close water valve F.
7. **Open wide the main control valve.**

SUPERTRON DELUGE SYSTEM SUPERTRON PREACTION SYSTEM

INTRODUCTION

The Model B Deluge Valve is also used in two systems known as the Supertrol Deluge System (Fig. 209) and the Supertrol Preaction System (Fig. 210). These two Supertrol systems are very similar, the difference being the addition of closed heads, supervisory air, and a check valve on the preaction system.

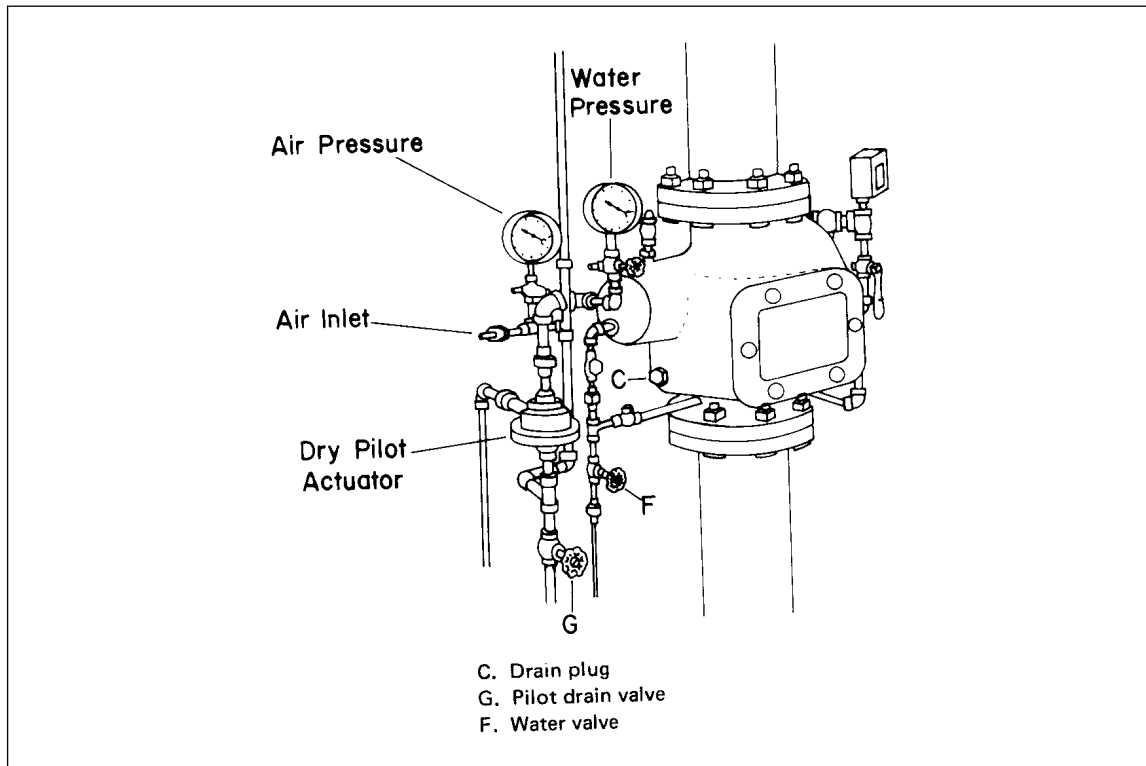

Fig. 208. Deluge valve with Model A actuator, actuator trim.

DESCRIPTION

(Refers to both systems unless otherwise stated.)

Detectors

Any FM approved 24-volt d-c normally open detector may be used. For example, a heat actuated detector of either fixed temperature or rate of rise type; or a smoke detector of either the photoelectric or ionization types.

Model CRB-1 Control Panel

The Control Panel D (Fig. 209) supplies power to operate detectors, alarms, and the release valve G. All equipment is constantly supervised such that any fault causes a trouble alarm to sound. A fault condition in any detector loop causes the control panel to automatically switch to emergency operation. In this mode fire protection is not impaired. The panel pulses the faulty circuit at four-minute intervals until the circuit is fixed. Once fixed the panel resets automatically to normal supervisory condition.

In the event of a primary (110 VAC) power failure, the control panel automatically switches to battery power. The batteries should supply power for a minimum of 90 hours.

Release Valve

The Reliable Model No. LV2LB×25 solenoid valve is approved as the release valve for this system (G, Fig. 209 and 210).

Check Valve (on Preaction System)

Any FM approved single check valve may be used to confine system air pressure.

Air Supply (Preaction System)

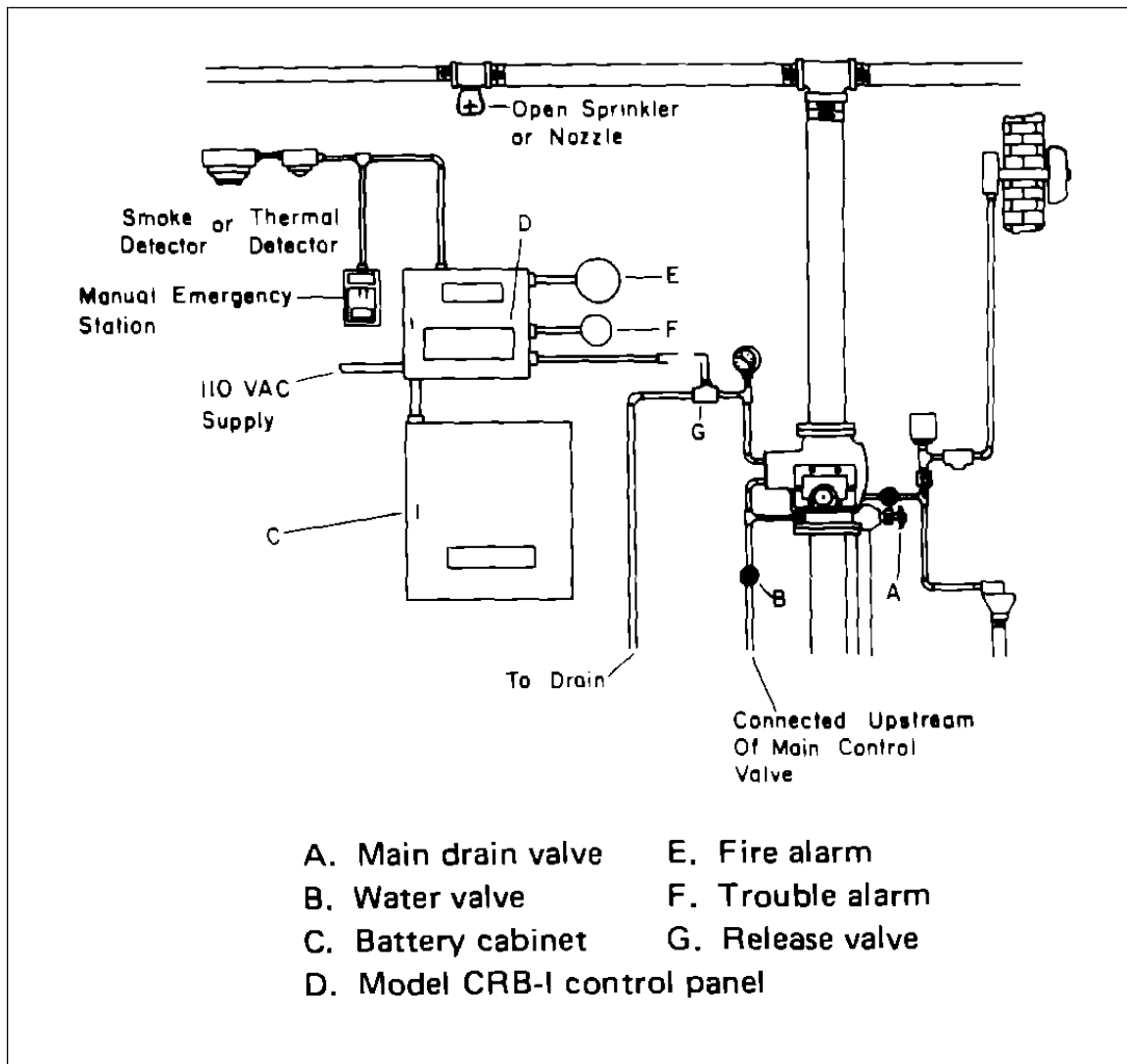

Fig. 209. Supertrol deluge system.

Air is pressurized to approximately 1.5 psi in the preaction sprinkler system. If a sprinkler operates or piping is broken, the pressure is lost and causes an alarm to sound. Pressure may be maintained by either the Model A air compressor panel with associated components or the Model C air pressure maintenance device using shop air.

Model A Air Compressor Panel. The component arrangement of the Model A compressor panel is shown in Fig. 211. The air pump 1 is a Neptune-Dyna Model 4K104. The pump has a rated capacity of 21 ft³ of air per hour. Maximum pressure is 18 psi. It is driven by a 1.32-amp, 1550-rpm, 115-volt, 60-cycle a-c electric motor.

The sprinkler alarm switch 5 is Type J27AX Model 6290 dual switch, manufactured by United Electric Controls Co. This has two pressure switches. One switch is factory set to start the air compressor when system pressure drops to 1.0 psig and to stop the compressor when system pressure reaches 1.5 psig. The other switch is factory set to operate the low-air warning light 3 and horn 4. With the silence switch in normal position, the low-air warning light is energized and the horn sounds when system pressure drops to approximately ½ psi. The silencing switch does not affect the operation of the air warning light but does silence the horn. With the switch in silence position, the horn is silenced for pressures of 1 psi or less. The horn will then sound when pressure goes above 1 psi, therefore requiring manual restoration of the silencing switch to the normal position after the pressure has been restored to normal.

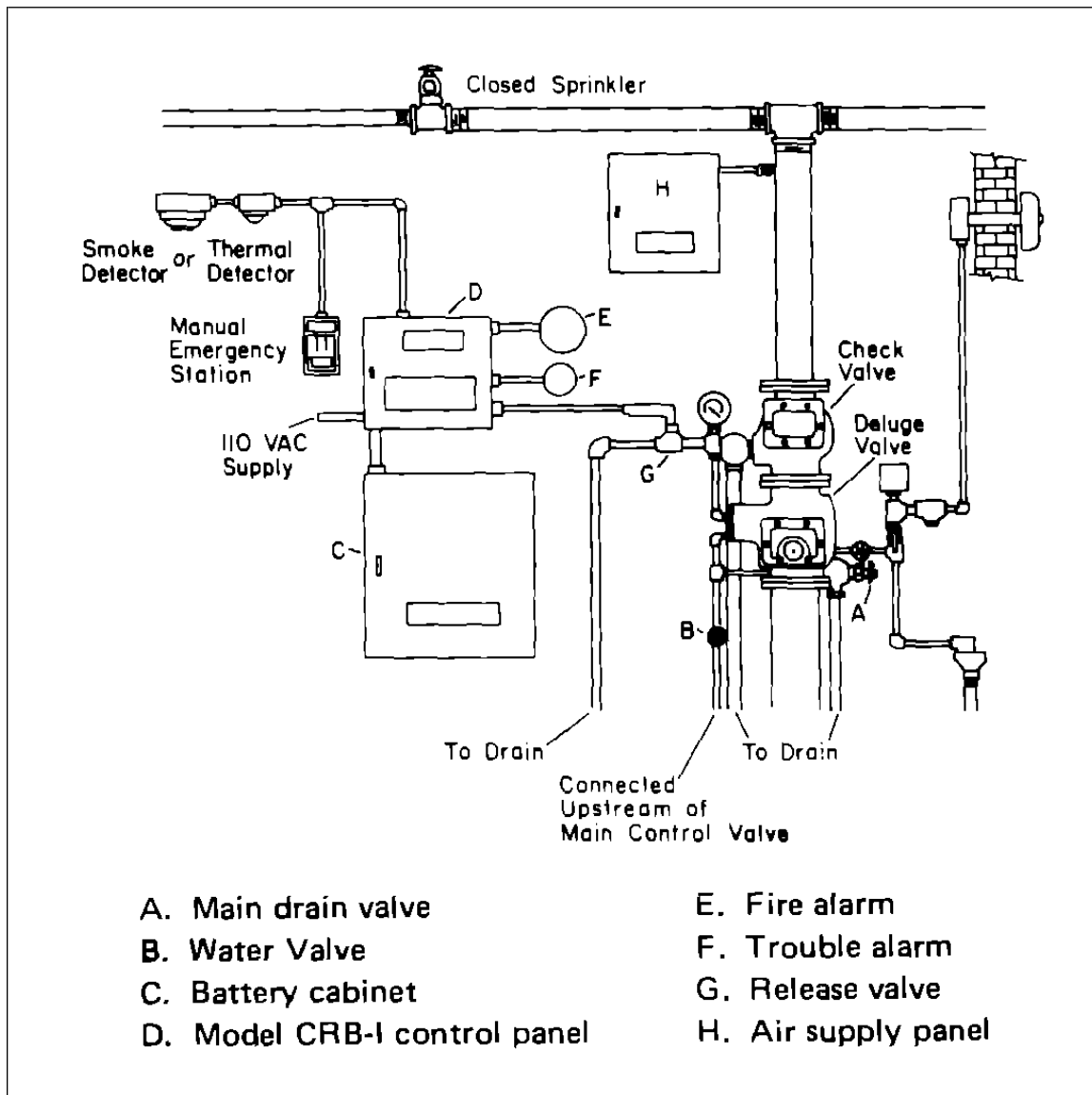

Fig. 210. Supertrol pre-action system.

Model C Air Pressure Maintenance Device. The Model C air maintenance device (Fig. 212) is used where the source of air supply is from the plant air system. The air maintenance device is the Model 2403C2H42 made by Bastian-Blessing Co. This device reduces the plant air pressure to 1.0 to 1.5 psi for use in the sprinkler system.

The Model 26X-6299 Low Pressure Alarm switch 3 manufactured by United Electric Controls Co. is used to sound an alarm when sprinkler system air pressure drops to 1/2 psi.

A 1/2-in. check valve 4 is provided upstream of the alarm switch to prevent water from entering the air maintenance device.

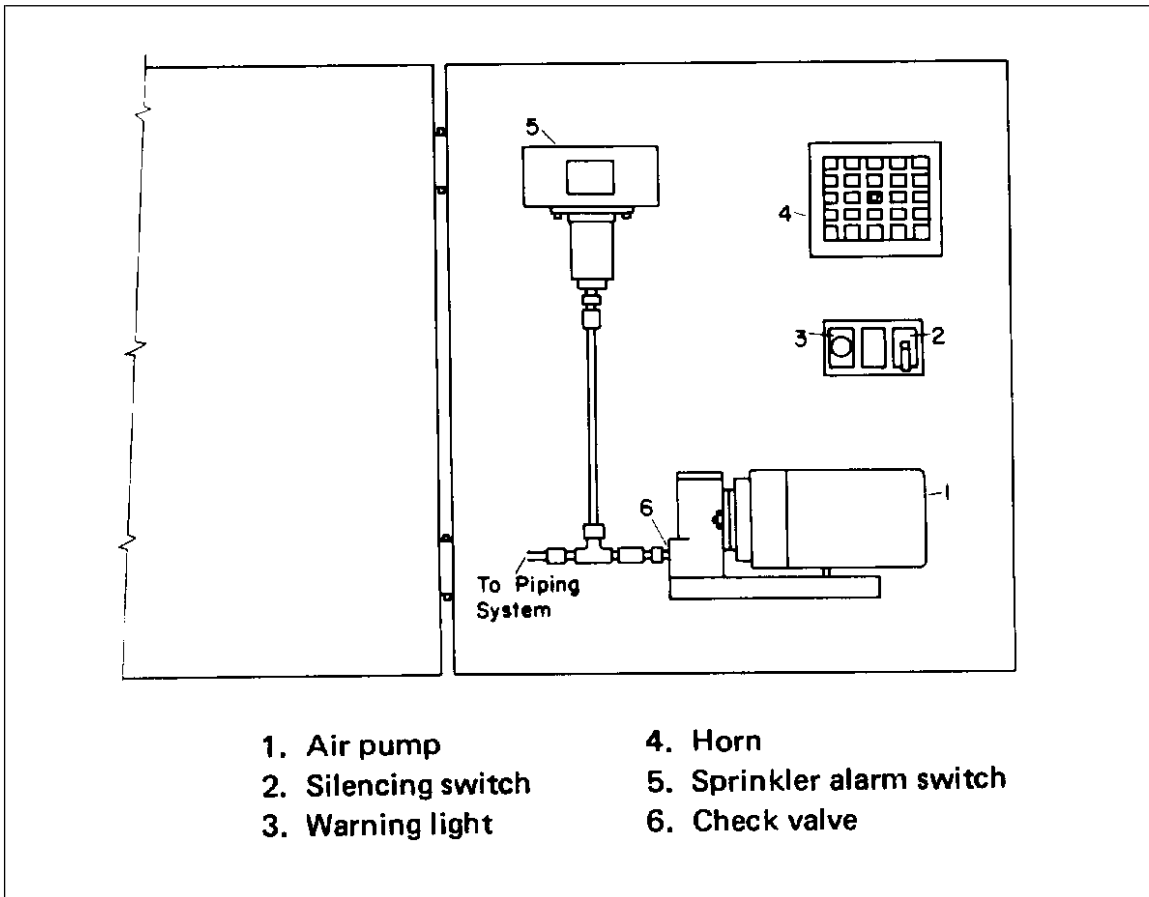

Fig. 211. Model A compressor panel

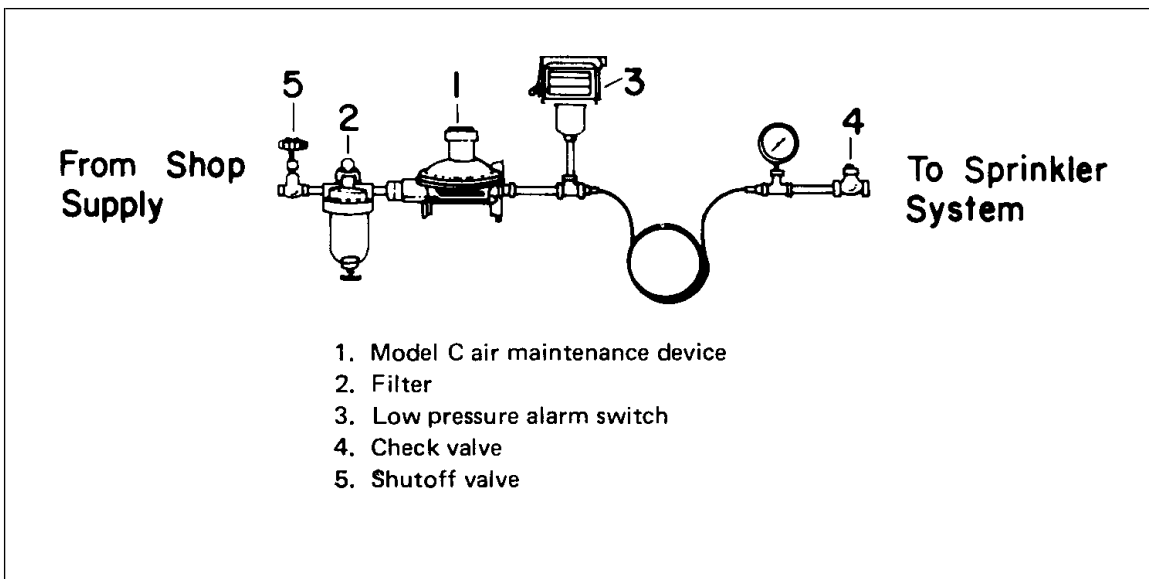

Fig. 212. Model C air maintenance device.

4.10 Rockwood Model K-2

**Deluge Systems
WITH ROCKWOOD WATER-CONTROL VALVE MODEL K-2
2-Inch - 1956 to Date**

The Model K-2 automatic water-control valve (Fig. 213) is essentially a single-swing clapper check valve in which the rubber-faced clapper (3) is held on its seat by mechanical linkage. The linkage assembly consists of internal release lever (4), plunger (5), external release lever (8) and release rod (11). The clapper is loaded by clapper spring (14) which retains it in a wide open position, upon operation. The plunger is hinged to the internal release, and has a neoprene circumferential facing (6) which seals off the opening in the valve body when water flows through the valve. Loading of lever spring (13) limits the movement of the internal release lever. A ball drip (20) installed in the threaded connection in the valve body opposite the clapper hinge accommodates any small leakage that may occur past the clapper.

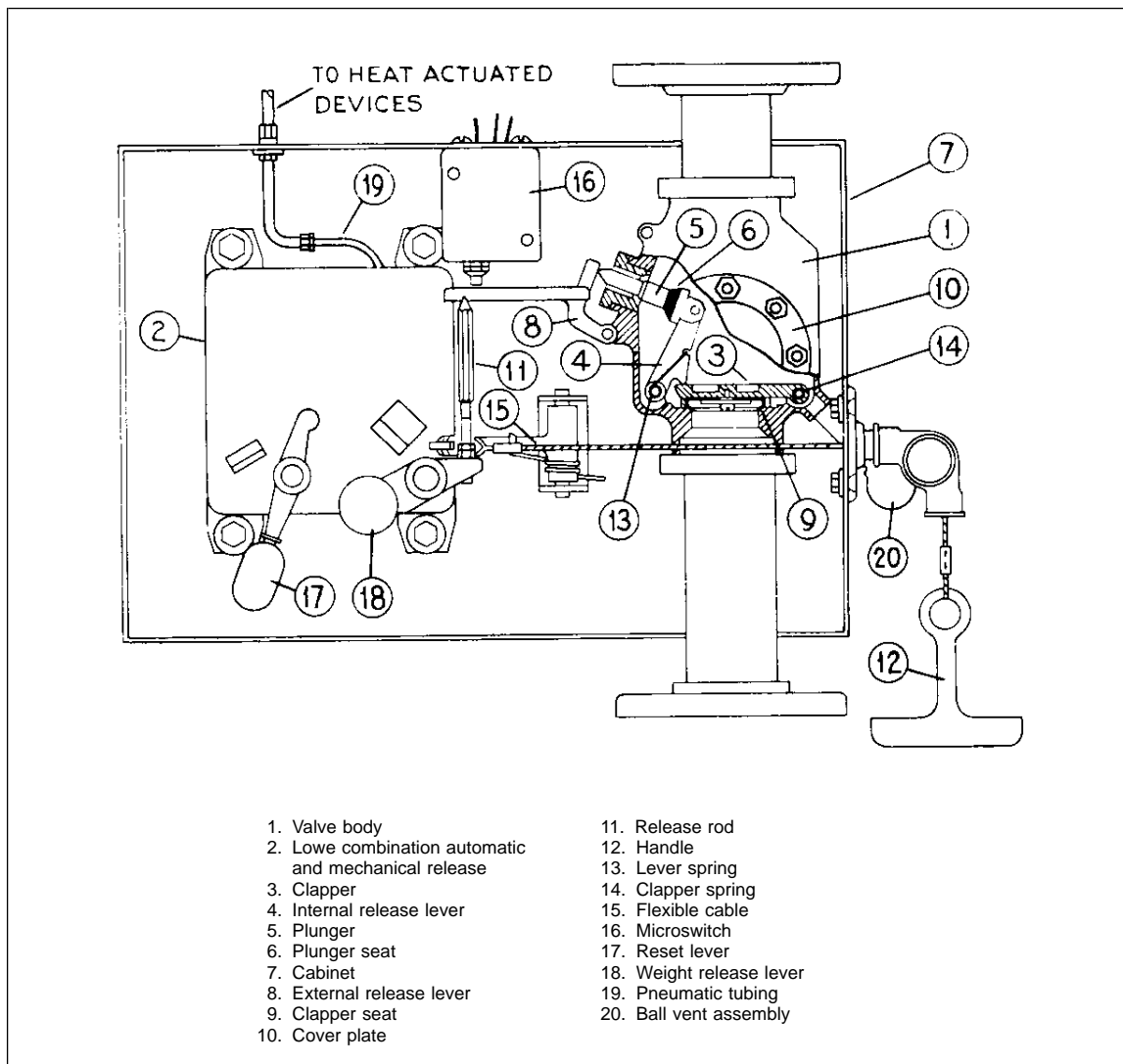

Fig. 213. Rockwood Model K-2 (2-in.) water-control valve and release.

Releasing Mechanism

The releasing mechanism for the automatic water-control valve is a mechanical type rate-of-rise device manufactured by the "Automatic" Sprinkler Corporation of America (Model 80-100, or Lowe Release.)

Manual operation of the valve is accomplished by an outward pull on handle (12) and cable (15), removing release rod (11) and its restraint of the external release lever.

A microswitch (16) is mounted over the release box with switch plunger normally depressed by contact with the external release rod. Removal of the rod upon operation of the deluge valve either automatically or manually will initiate an electrical signal. The automatic water-control valve manufactured between 1956 and 1958 differs from subsequent models in that a snap-action type switch was provided on the side of the release box in lieu of the present microswitch. With that arrangement, an alarm would be initiated only when the deluge valve operated automatically.

Actuating Mechanism

Automatic control of the release mechanism is accomplished through the use of heat-actuated devices (pneumatic thermostats) located so as to detect fires in the area protected. These thermostats operate on a rate-of-rise of temperature determined by the area of the orifice in the compensating vent. Pressure in the thermopneumatic system is set at 1½ inches of water column and a No. 10 vent accommodates normal temperature fluctuations.

OPERATION

Under normal conditions, water pressure acts upward and against the clapper of the valve, tending to raise it. This upward force is opposed by the greater downward force exerted through the mechanical linkage arrangement of the valve in conjunction with the release.

When fire occurs, the air pressure within the HAD's in the fire area increases and is transmitted through copper tubing to the release. Operation of the release removes the downward force acting on the valve clapper, permitting the clapper to be forced open by water pressure. The clapper is spring loaded and remains open until reset manually. The action of the clapper and its spring moves the internal release lever clockwise until the facing of the plunger makes contact with the bushing, preventing leakage past this point. When flow ceases, the seat moves away from the bushing and the water remaining in the sprinkler piping will slowly discharge from this opening.

SETTING

1. Close the valve controlling the water supply to the system.
2. Open the ¾-in. drain valve below the automatic water-control valve to drain the system.
3. Turn the reset lever on the release clockwise to lock the weight release lever in position.
4. Remove the cover plate from the automatic water-control valve and clean the seats and facings of the clapper and plunger.
5. Reseat the clapper and hold down with internal release lever.
6. Transfer load to the external release lever by holding the latter against the plunger where it extends through the side of the valve. Pressure on the microswitch plunger automatically resets the alarm.
7. Place the pointed end of the release rod into the opening on the underside of the release lever and slide opposite end into the slot in the weight release lever, first making sure that the arm of the manual release is behind the release rod.
8. Replace the cover plate. Tighten nuts evenly.
9. Close the ¾-in. drain valve and slowly open the main water supply valve. If there is no leakage past the clapper as evidenced by discharge from the ball drip, the valve is tight and the main control valve should be opened wide.
10. Test the drain valve below the automatic water control valve and, if satisfactory, seal the main water supply control valve in the open position. The system is now in service.

MAINTENANCE AND INSPECTION

Deluge systems require careful maintenance, inspection and testing by specially trained personnel. Unless a plant has such specialists available, it is advisable to purchase these services under a contract arrangement with the system manufacturer or installer. Only minor, readily apparent adjustments or repairs should be made by personnel other than specialists.

The automatic water-control valve should be trip-tested annually.

PROCEDURE FOR OPERATING TESTS

1. Connect the electric test set supplied by the manufacturer to a 110/120 volt supply for about 15 minutes before testing begins.
2. In advance, notify the fire department, central station supervisory service, or other agencies which may receive signals during the test procedure.
3. Close the main water supply control valve to the system.
4. Open the 3/4-in. drain below the automatic water-control valve.
5. Apply the electric test set to the most remote HAD, or test thermostat if one is provided, noting the time required to trip the automatic release. Operation should occur within five to twenty-five seconds. In areas where pyroxylin or other hazardous materials are used or stored, immerse the thermostat in a small container of hot water instead.
6. Wait a few minutes after removing the heat from the HAD to allow air pressure in the release to become equalized with the atmosphere through the compensating vent. Then reset the release mechanism as described under Setting, beginning with Step 3.

4.11 Star Electromatic Model D

**Deluge Systems and Preaction Sprinkler Systems
With Star Electromatic Automatic Water Control Valve Model D
3 IN. (76 MM) 1948
6 IN. (152 MM) 1948**

DELUGE SYSTEM

Water Control Valve

The Star Model D automatic water control valves (Fig. 214 and 215) are single-swing clapper check valves in which the metal-faced clapper is held on its molded rubber seat disc by a retaining lever. Operation of the triple action release (Fig. 214 and 215), actuated by an electric power unit (Fig. 216) and control unit (Fig. 217), allows water pressure to open clapper 1.

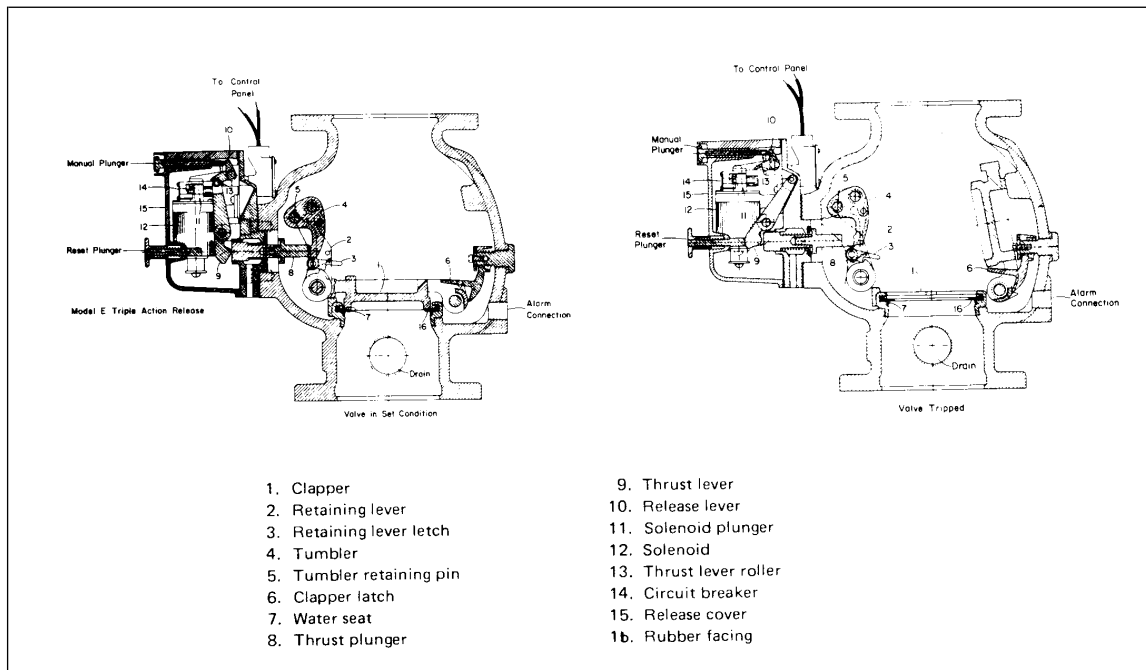

Fig. 214. Star Electromatic Model D water control valve, 6-inch (152-mm), with Star Model E Triple Action Release.

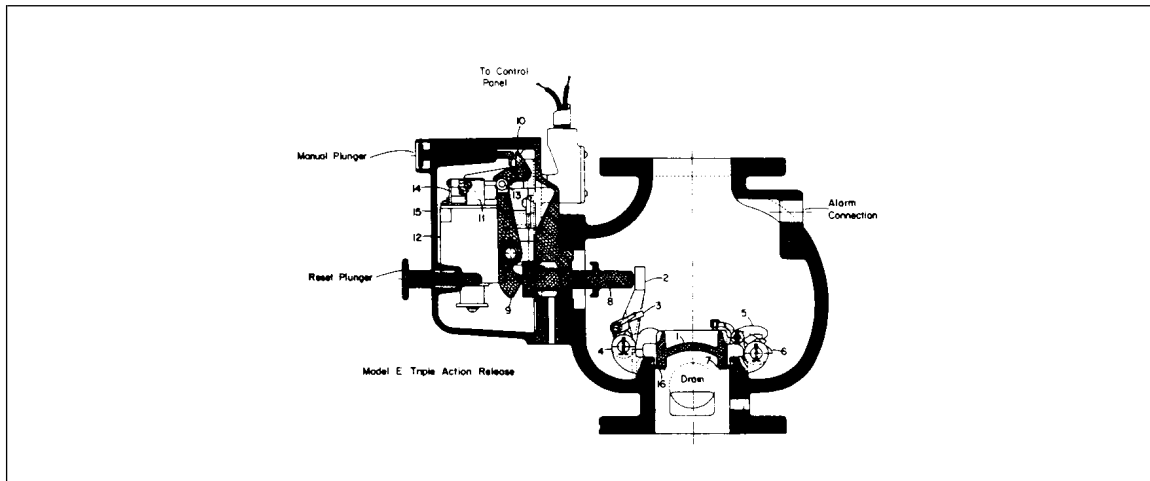

Fig. 215. Star Electromatic Model D water control valve, 3-inch (76-mm), with Star Model E Triple Action Release.

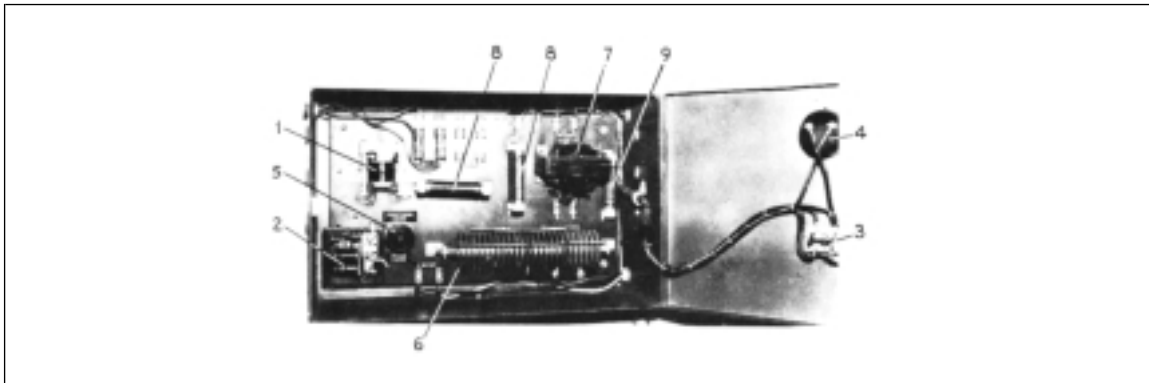

Fig. 216. Star Model D-1 power unit.

Schematic. Wiring diagram of the electrical circuit for the Star automatic water control valve Model D. Relay, thermostat, and McCulloch switch contacts are shown in the energized or normal operating position. Contacts A1, A2, A3 and A4 are part of the double throw McCulloch circuit switch. Numbers near circles indicate terminal strip numbers in the Star Model D control unit. For example, wires to the trouble signal are connected to terminals 11 and 12 which are located at the right of release supervisory relay 4.

In the 3-in. (76-mm) valve, retaining lever 2 (Fig. 215) is hinged to seat ring 4 and held in place by thrust plunger 8. In the 6-in. (152-mm) valve, retaining lever 2 (Fig. 214) is hinged to the valve body and held in place by tumbler 4 (Fig. 214) which rests against thrust plunger 8.

In both valves thrust plunger 8 extends through the valve body and is a part of the Star Model E release mechanism. A latching mechanism prevents the clapper from returning to its seat after the valve has tripped.

Releasing Mechanism

The Star Model E triple action release (Fig. 214 and 215) is operated either manually or electrically. In set position thrust lever 9 holds thrust plunger 8 against tumbler 4 (Fig. 214) or retaining lever 2 (Fig. 215). Thrust lever 9 is kept in position by thrust lever roller 13 resting in a notch on release lever 10. The release lever is operated manually by depressing the manual plunger, and electrically by the raising of solenoid plunger 11 when solenoid 12 is energized by the control and power panels after operation of a fire detection thermostat.

The releasing mechanism can be tripped manually for water supply pressures up to 100 psi (689 kPa) (6.89 b).

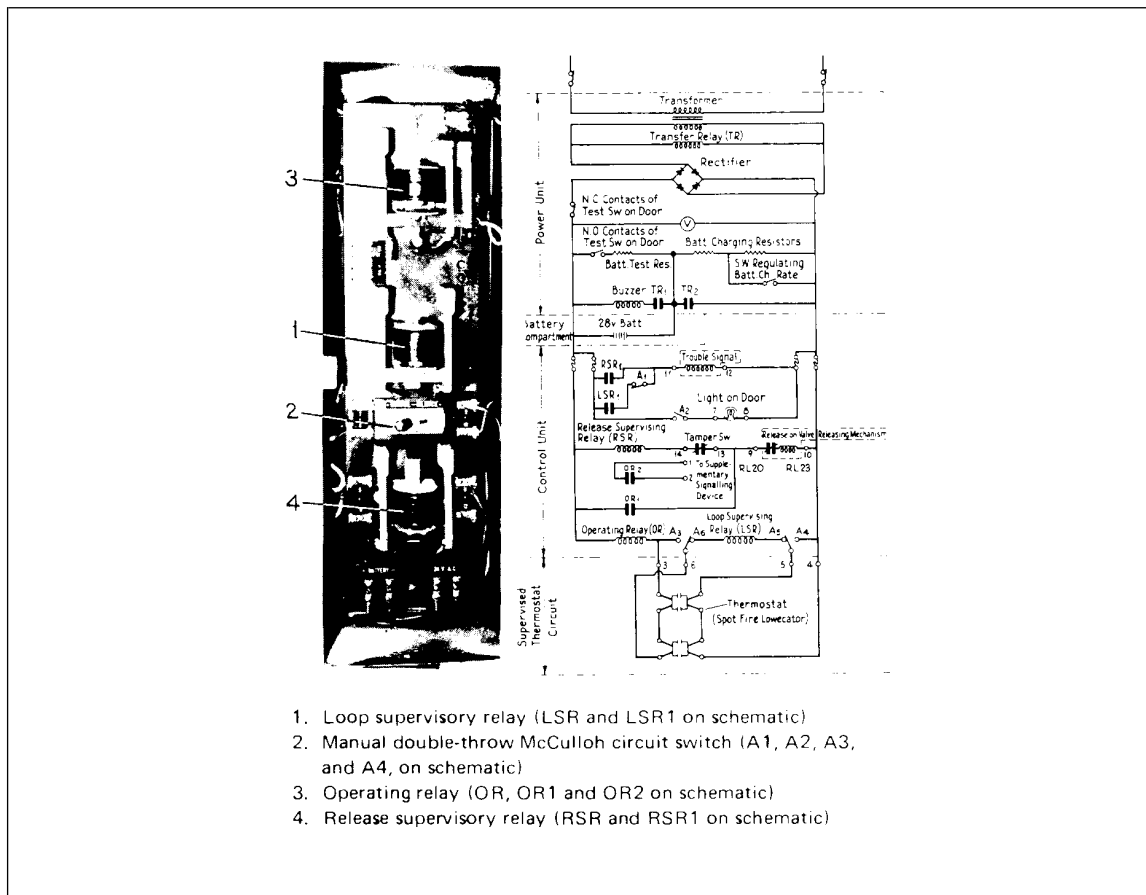

1. Loop supervisory relay (LSR and LSR1 on schematic)
2. Manual double-throw McCulloch circuit switch (A1, A2, A3, and A4, on schematic)
3. Operating relay (OR, OR1 and OR2 on schematic)
4. Release supervisory relay (RSR and RSR1 on schematic)

Fig. 217. Star Model D control unit.

Fire Detection Device

The fire detection thermostats are Star Spot Fire Lowecators which operate by both rate-of-rise and fixed temperature.

Power Units

The Model D-1 Electromatic power unit (Fig. 216) normally furnishes 28 volt direct current from a reliable a-c source to the control unit (Fig. 217). Should the a-c source fail, the power panel provides for automatic switchover to a 28-volt storage battery. The power panel also includes a trickle battery charger, a buzzer to indicate failure of a-c power, and a means for testing the condition of the battery under load.

The Model D-6 electromatic power unit is used when more than one control cabinet is supplied. The D-6 unit is identical to the D-1 power unit except that the rectifier has twice the current rating.

Battery Compartment

The battery is housed in a separate steel cabinet. Leads are short and enclosed in rigid metal conduit. With the D-1 power unit, or with the D-6 unit supplying two or three control cabinets, a single 28-volt glass cell storage battery rated at 18-ampere hours is used. When four, five, or six control cabinets are to be supplied by the D-6 power unit, two sets of 28-volt batteries are connected in parallel.

Control Unit (Fig. 217)

The Star Model D electromatic control unit is enclosed in a substantial locked metal cabinet. A detector circuit (loop supervisory) relay, a release supervisory relay, and an operating relay are mounted on a panel at the rear of the cabinet. The operating relay has auxiliary contacts for connecting by open or closed circuit to a local annunciator or central station supervisory system.

A manual double-throw key-type switch is mounted in the cabinet for converting the closed circuit detector system to two open circuit systems if there is a break in the wiring, with each circuit operative to the point where the break exists. This system is a typical manual McCulloh circuit and provides protection until repairs are made. A light indicates when the switch is not in a normal closed position.

Public Utility Generating Stations

Deluge systems installed in public utility generating stations exclude the power panel with triple action release. Control panels are provided with voltage ratings that conform to voltages available, usually 48-, 125-, or 250 volts direct current.

PREACTION SPRINKLER SYSTEMS

The installation of the Model D water control valve in a preaction sprinkler system (Fig. 218) is the same as in a deluge system except that devices are added to provide for supervisory air pressure in the sprinkler piping. A rubber-faced check valve is provided above the water control valve to confine supervisory air pressure. Supervisory air is supplied by an automatically controlled electrically operated pump. Components include the air compressor and motor, compressor control switch, low-air-pressure signal switch, relief valve, strainer, check valves, toggle switch, and pipe fittings.

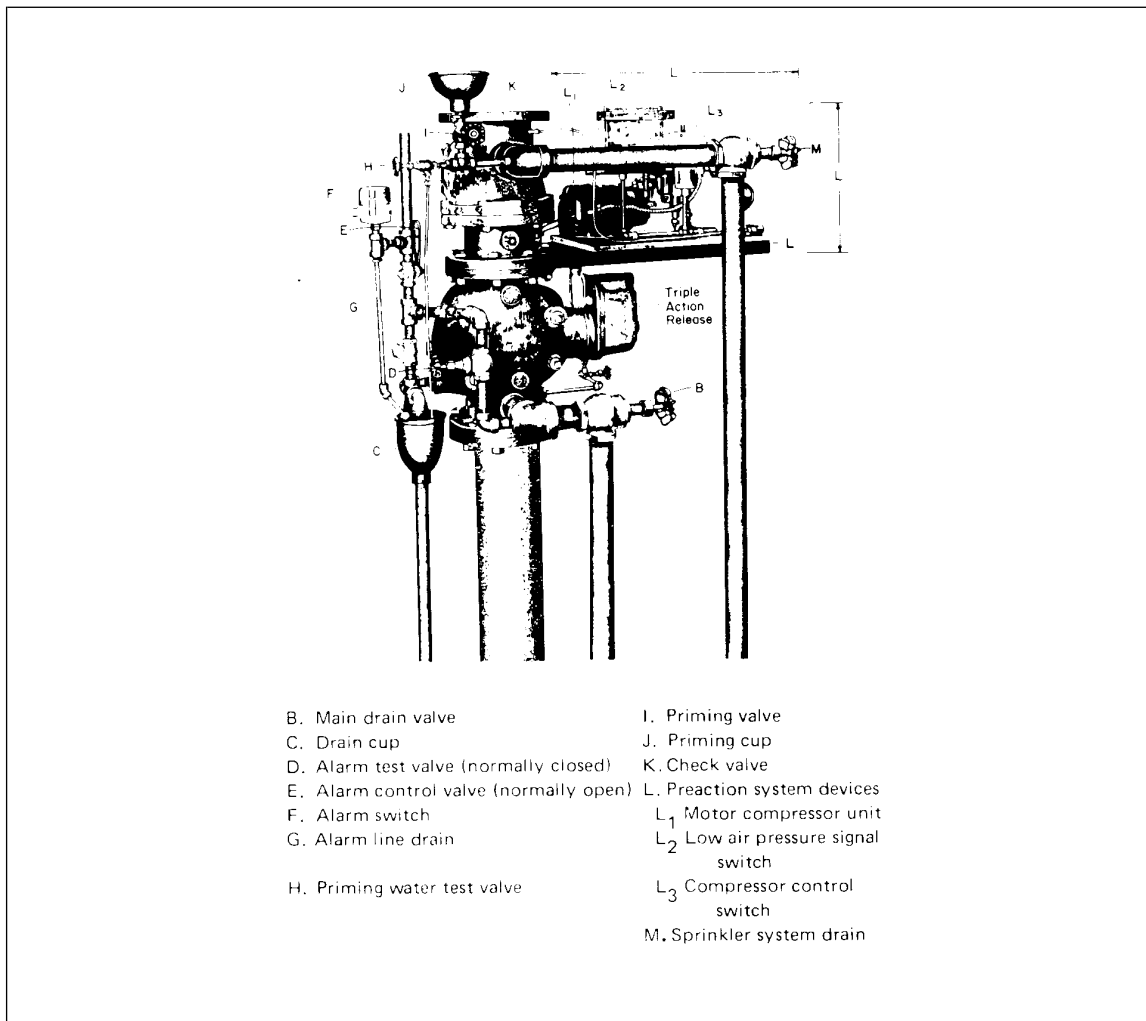

Fig. 218. Star Electromatic Model D water control valve with preaction trim. (In deluge systems the preaction devices, H to M inclusive, are not used, and the riser connects directly to the Model D valve.)

Provision is also made for priming and for checking priming water levels at the check valve. The sprinkler system piping can be drained through the valve in the drain line at the check valve.

The compressor control switch maintains air pressure between 2 ½ and 4 psi (17 to 27 kPa)(0.2 to 0.3b). An air relief valve set at 10 psi (69 kPa)(0.7b) prevents excessive pressure in the sprinkler piping. Check valves in the line protect the air pressure controls and the air compressor unit from high water pressure when the system operates.

OPERATION

Heat from a fire causes the contacts of the fire detection device to close and short out the coil of the loop supervising relay (LSR, Fig. 217), closing its contacts (LSR1, Fig. 217) and actuating a trouble signal. Increased current flows through the operating relay (OR) closing its contacts (OR-1 and OR-2), which actuate a supplementary signaling device at an annunciator board, central station service, or other location, and also shorting the relief supervising relay (RSR). In turn, increased current flows through solenoid 12 (Fig. 214) moving solenoid plunger 11 upward causing release lever 10 to rotate. Thrust lever 9 pivots, operating circuit breaker 14, removing power from solenoid 12. Thrust plunger 8 is released and water pressure forces clapper 1 open.

Failure of Normal Power Supply

Refer to Fig. 217 schematic.

When the a-c voltage falls below 52 volts, the coil of transfer relay (TR) is de-energized and closes its contacts (TR-1 and TR-2). This closing completes the circuit to the buzzer indicating power failure, shorts out the battery-charging resistors, and connects the batteries so that it will provide power to the supervisory circuit and proper operation of the system.

At public utility generating stations, if the primary d-c voltage fails, a transfer switch automatically changes over the load to the station's emergency storage batteries.

Break In Thermostat Supervisory Circuit

Refer to Fig. 217 schematic.

If the looped wiring to the thermostats breaks, the current in the loop supervising relay (LSR) is interrupted, causing the relay to be de-energized and to close its contacts (LSR-1), completing the circuit to the trouble signal. The trouble signal continues to sound until the break is repaired or until the manual double-throw switch is thrown from the normal to the silent position. In the silent position contact A-1 opens, contact A-2 closes, completing the circuit to the light on the door of the control unit cabinet. Contact A-3 closes completing the circuit from the operating relay (OR) to one side of the loop, and contact A-4 closes completing the circuit to the other side of the loop. Contacts A-5 and A-6 open removing the coil of the loop supervising relay (LSR) from the circuit. The system then operates as an open-circuit unsupervised system until repairs are made.

Release Device Supervisory Circuit

The continuity of wiring for the two solenoids 12 (Fig. 214 and 215) is supervised by a release supervising relay (RSR). Current flowing through the circuit is sufficient to energize the release supervising relay, but not high enough to operate the solenoids. If the wiring breaks, the coil of the release supervising relay (RSR) de-energizes and closes its contact (RSR-1), completing the circuit to the trouble signal.

Leak Or Break In Sprinkler Piping (Preaction Sprinkler System)

Preaction system devices (Fig. 218) incorporate a low air pressure switch which operates an audible trouble signal when air pressure drops to about 2 psi (14 kPa)(0.1b) in the sprinkler piping. Moving the toggle switch to the "R" position de-energizes and silences the trouble signal, and energizes a red light. When air is increased to about 2 psi (14 kPa)(0.1b), the trouble signal is energized again. Moving the toggle switch to *normal* de-energizes the trouble signal and red light.

SETTING

1. Close the main control valve supplying water to the system deluge valve. Open main drain valve B (Fig. 218). With a preaction system, open sprinkler system drain M (Fig. 218). Close these valves when water ceases to flow.
2. Remove the cover plate from the deluge valve and carefully clean clapper 1, water seat 7, and rubber facing 16. (Fig. 214 and 215)

3. On the 6-in. (152-mm) valve (Fig. 214) lower clapper 1 to its seat by releasing clapper latch 6. Simultaneously, raise retaining lever latch 3 which moves the upper end of retaining lever 2 clockwise and exerts a counterclockwise pressure on the lower end of tumbler 4. Release tumbler 4 after the leading edge of retaining lever 2 has passed under tumbler retaining pin 5. Move retaining lever 2 to make sure that the final set has been obtained at all contact points.

On the 3-in. (76-mm) valve (Fig. 215) lower clapper 1 to its seat by releasing latch pawl 5. Lift retaining lever latch 3 and move retaining lever 2 to the upright position, making sure that the toe on retaining lever 2 is securely engaged above the extension on clapper 1.

4. Push the reset plunger (Fig. 2141 and 215) until it engages and resets the release mechanism. If the mechanism will not reset, examine the thermostats and the thermostat electric circuits. Replace any thermostat in which the fixed temperature elements have fused. Correct any wiring defects. The release mechanism will not reset if any of the contacts in the thermostats are closed, if there is a short in the wiring, or if the contacts in any manual fire alarm stations have not been returned to their open positions.

5. Replace the cover plate on the deluge valve.

6. Open main drain valve B slightly. Open the main control valve slowly until water flows from main drain valve B. Close main drain valve B slowly and **open wide the main control valve**. In addition, with preaction systems prime check valve K through priming cup J.

7. Test the water supply by opening main drain valve B.

MAINTENANCE, INSPECTION, AND TESTS

Refer to Data Sheet 2-81, *Inspection and Maintenance of Sprinkler Systems*. In addition, the following procedures should be followed.

Monthly

Check the condition of the storage batteries as follows. Open the door of the power unit (Fig. 216) and make sure that charge regulating switch 5 is in the trickle-charge position. Close the cabinet door and hold battery condition test switch 3 depressed for 30 seconds, noting the reading of voltmeter 4. The reading should not be less than 25 volts. If a lower reading is obtained, move charge-regulating switch 5 to the trickle-charge position and repeat the test. If the voltage rating is again less than 25 volts, replace the battery.

Quarterly

Check operation of the transfer relay (Fig. 217 schematic) as follows. Open the cabinet of the power unit (Fig. 216). Have the main switch in the a-c line supplying the power unit opened momentarily. Observe that this de-energizes transfer relay 1 (Fig. 216) and sounds indicating buzzer 2. Close the power unit cabinet.

Annually

On some systems, remote manually operated fire alarm stations are provided which are connected to the thermostat wiring loop. Remove the cover containing the glass panel and trip the release mechanism by depressing the pushbutton. Replace the cover containing the glass panel. Reset the release mechanism. The manual plunger (Fig. 214 and 215) should be moved to ensure proper operation.

4.12 Star Model F Hidromatic

Star Model F Hidromatic Deluge Valve

3 IN., 1964

6 IN., 1965

STAR MODEL AA DRY PILOT LINE ACTUATOR

1964

Star Sprinkler Corp., Philadelphia, Pa.

The Star Model F deluge valve is used to control the flow of water to special extinguishing systems of open sprinklers, spray nozzles, or mechanical foam-making equipment. It is basically the same as the Model D, the principal difference being a refinement to the "differential unit" which is part of the tripping mechanism.

Under normal conditions, the deluge valve is held closed by hydrostatic pressure imposed on a clapper within a chamber (differential unit). Water pressure is admitted to this chamber through a 1/8-in. orifice in a line from below the main supply valve. Whenever water pressure in the chamber is released to atmosphere faster

than it can be supplied through 1/8-in. orifice, the deluge valve will trip. Release of pressure from this chamber to cause subsequent operation of deluge valve may be accomplished by any one of the following methods.

1. Automatic. Operation of one or more closed sprinklers in the wet or dry pilot line.
2. Manual. Opening of one or more manually operated valves arranged for remote or local operation at the deluge valve.

The Model AA actuator, a diaphragm operated valve, is used with a dry pilot line. Release of pressure from the pilot line moves the actuator diaphragm to open a port and release the pressure from the enclosed chamber of the deluge valve.

DESCRIPTION

Model F Deluge Valve. The 3-in. deluge valve (Fig. 219) is basically identical to the 3-in. Model F dry pipe valve and the 6-in. deluge valve (Fig. 220) is similar to the 6-in. Model F dry pipe valve (Data Sheet 2-87). Clapper latch assembly, retaining lever, and auxiliary valve assembly are also identical to those of the Model F valve.

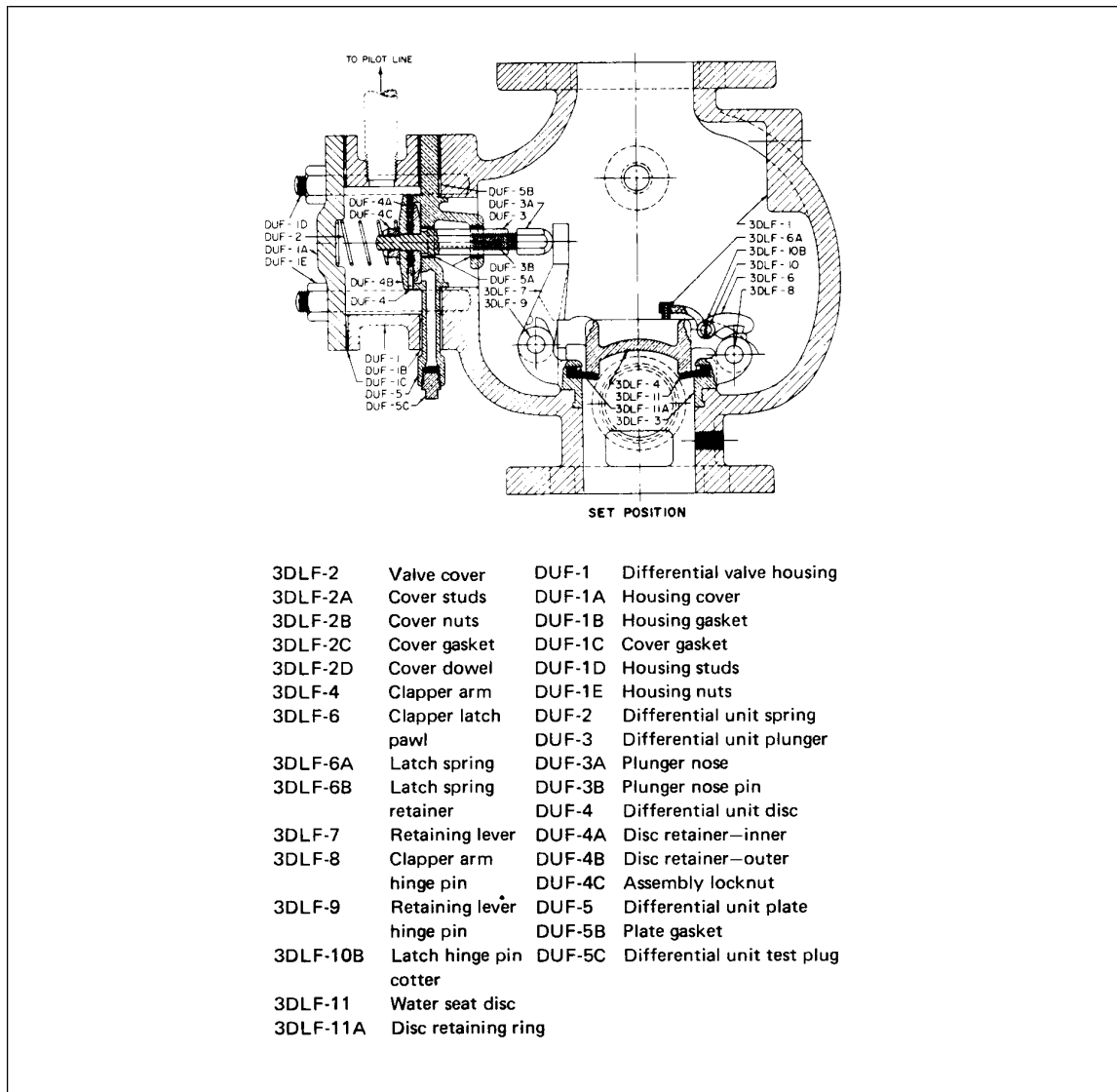

Fig. 219. Star Model F 3-inch deluge valve.

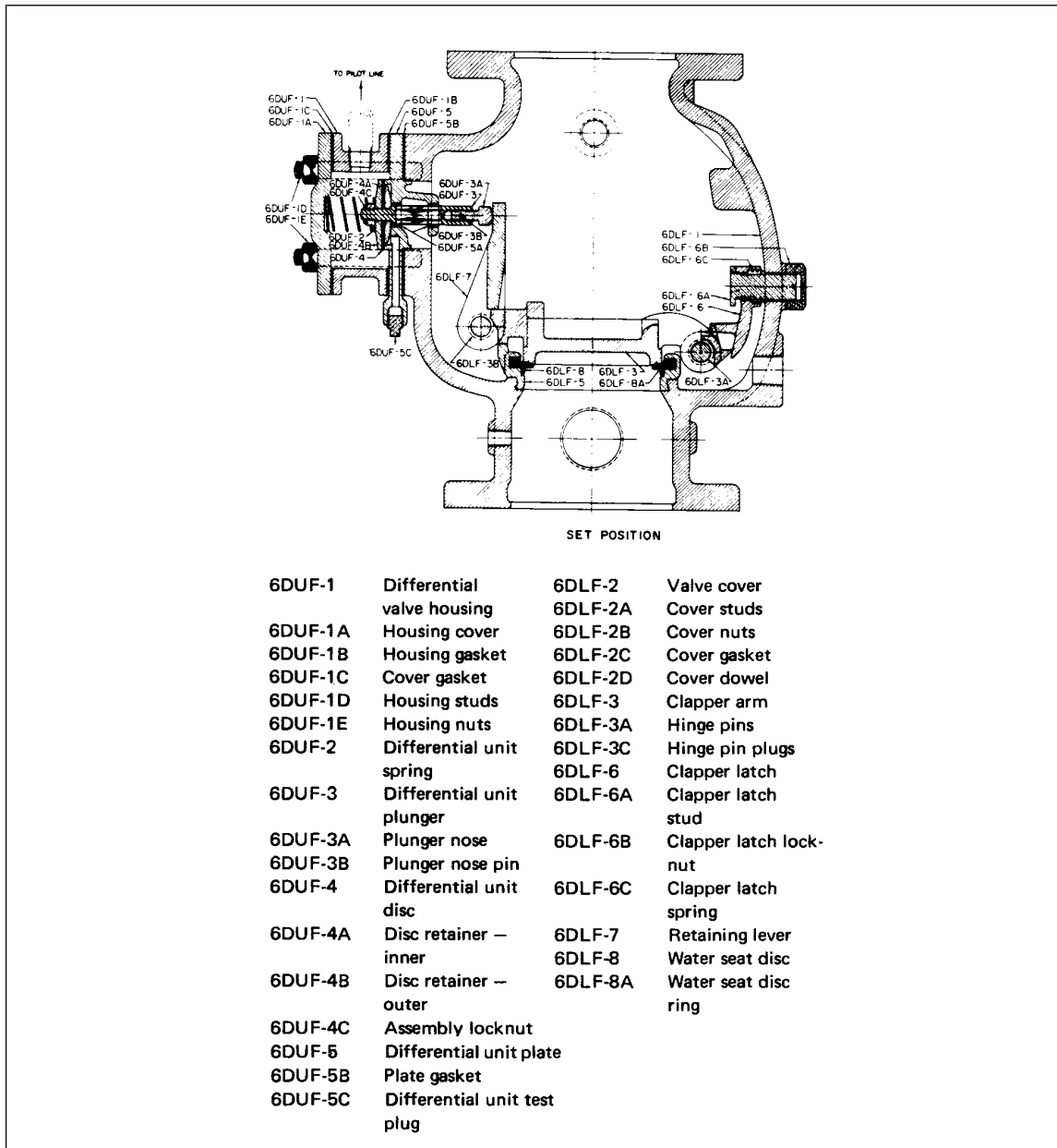

Fig. 220. Star Model F 6-inch deluge valve.

The differential housing is in two parts. The pilot line is piped to the body of the housing, and the cover allows for inspection of the differential valve without dismantling piping.

Model AA Actuator. The Model AA actuator (Fig. 221) is made up of a two-piece cast iron body which encloses a diaphragm and valve assembly. The diaphragm support plate (3A) is held against the plate ring (3B) by pressure in the pilot line. The operating spring (3C) is compressed under normal conditions. The guide bushing (5) has six $\frac{7}{16}$ -in.-dia. holes in the upper section. The discharge orifice seal (4B) prevents passage of water from the deluge valve to the drain.

Pressure Line and Pilot Line Pressure Supply. The pressure supplied to the pilot line of sprinklers will be from either a nitrogen cylinder, shop air system, or automatically controlled compressor.

The air or nitrogen pressure within the pilot line is controlled by a Bastian-Blessing Co., No. 3131, Type A, relief valve set at 100 psi. Normal pressure maintained in pilot line is 20 psi.

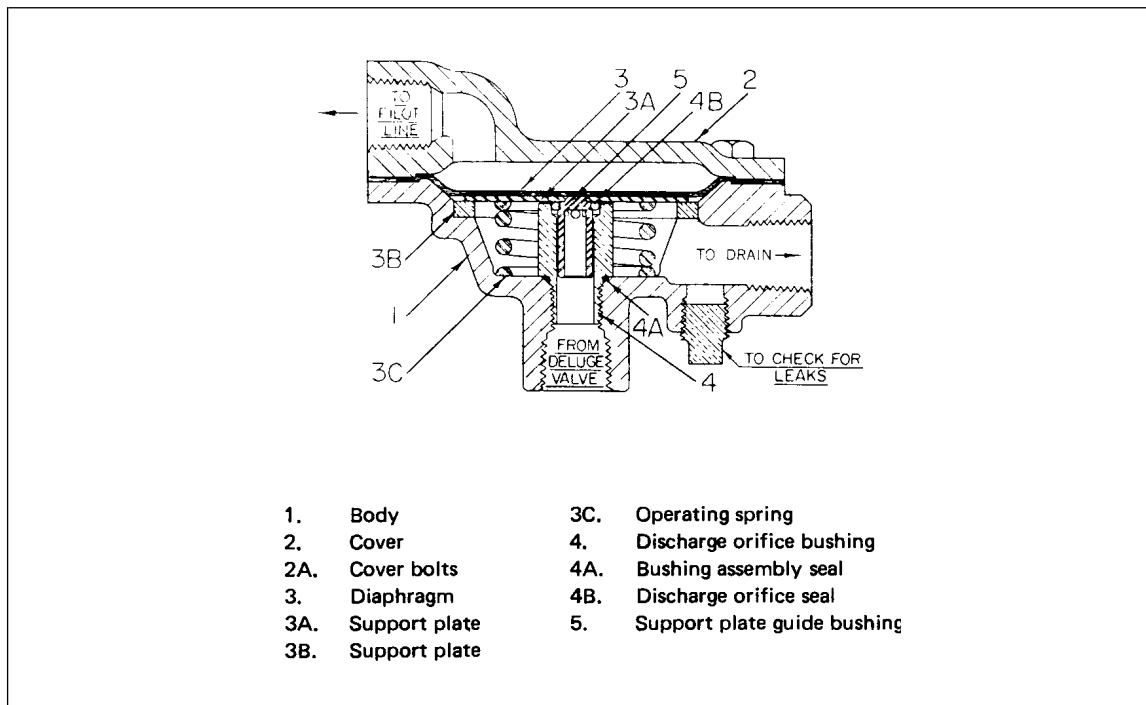

Fig. 221. Star Model AA pilot line actuator.

OPERATION

Deluge Valve. Water pressure is supplied through a differential chamber from the supply side of main water supply valve (13, in Fig. 222). Water pressure acting on top of the differential unit disc (DUF-4) creates a force which is transmitted and amplified at the deluge valve clapper. This force holds the clapper in closed position.

When the system is operated either manually or automatically, the pressure differential unit disc (DUF-4 or 6DUF-4) is released faster than it can be replaced through a relatively small supply restriction. The pressure on the disc is quickly reduced to the point where it is overbalanced by the pressure on the clapper, and the valve opens. Water flows through the waterflow alarm switch or water motor gong.

Model AA Actuator. Refer to Fig. 221. When pressure above diaphragm (3) is released by operation of a sprinkler in the pilot line, spring (3C) raises the diaphragm, support plate (3A), guide bushing (5), and orifice seal (4B). Water from the deluge valve, in passing to drains through opening in guide bushing (5), releases pressure in the differential unit to operate the deluge valve. When a dry pilot line is desired, the Model AA actuator is installed close to the deluge valve.

SETTING THE VALVE

1. Close main water supply valve for the deluge system and open main drain valve (4, in Fig. 222) of the water control valve, alarm line drains, and all other drain valves or plugs at the low points in the sprinkler system.
2. Push inward on the spring-loaded manual drain pin of the automatic drain valve (3, in Fig. 222) to be sure deluge valve is open and the body of the Hidromatic Valve has been drained.
3. **a. Setting differential unit on 3-in. valve (Fig. 219).** Remove the differential valve housing cover (DUF-1A). Do not lose or damage differential unit spring. Remove plunger assembly and wipe clean the seating surfaces on differential unit plate (DUF-5) and the bearing surfaces of plunger guide bushings (DUF-5A). Replace plunger assembly, differential unit spring (DUF-2), and housing cover (DUF-1A). Make sure differential unit spring (DUF-2) is in its proper position, over the assembly lock nut (DUF-4C) and in housing cover (DUF-1A) reset.

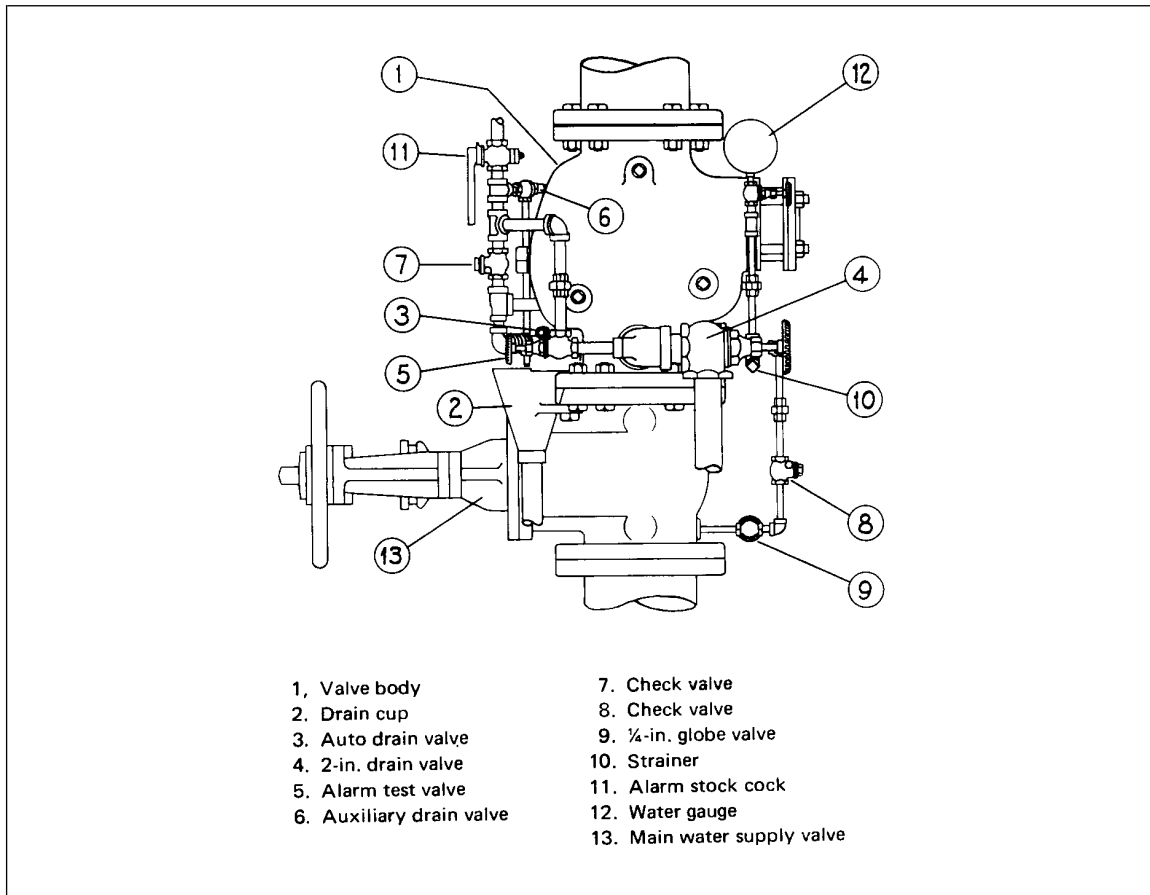

Fig. 222. Star Model F Hidromatic deluge valve.

- b. Setting differential unit on 6-in. valve (Fig. 220).** Remove the differential valve housing cover (6DUF-1A). Do not lose or damage differential unit spring (6DUF-2). Remove plunger assembly and wipe clean seating surfaces on the differential unit plate (6DUF-5) and the bearing surface of the plunger guide bushings (6DUF-5A). Replace plunger assembly, differential unit spring (6DUF-2), and housing cover (6DUF-1A). Make sure differential unit spring (6DUF-2) is in correct position over assembly lock nut (6DUF-4C) and in housing cover (6DUF-1A) reset.
- 4. a. Setting the 3-in. deluge valve (Fig. 219).** Remove cover (3DLF-2) and wipe clean water seat (3DLF-A), seat ring (3DLF-8A), seating surfaces, and clapper arm (3DLF-3). Make sure all hinging is free. Retaining lever (3DLF-7) should now move freely to the left, pushing plunger nose (DUF-3A) on plunger assembly along with it. Unlatch and lower clapper arm (3DLF-3) to the set position on its nose under the retaining lever (3DLF-7). There is approximately 1/16-in. clearance between the plunger nose (3DUF-3A) and the retaining lever (3DLF-7). Replace the valve cover (3DLF-2) and bolt tight.
- b. Setting the 6-in. deluge valve (Fig. 220).** Remove the cover (6DLF-2) and wipe clean the water seat (6DLF-8), seat ring (6DLF-8A), seating surfaces, and clapper arm (6DLF-3). Make sure all hinging is free. Retaining lever (6DLF-7) should move freely to the left, pushing plunger nose (6DUF-3A) on plunger assembly along with it. Unlatch and lower clapper arm (6DLF-3) into the set position with its nose under the retaining lever (6DLF-7). There is about 1/16-in. clearance between the plunger nose (6DUF-3A) and the retaining lever (6DLF-7). Replace the valve cover (6DLF-2) and bolt tight.
5. Close the alarm test valve (5, in Fig. 222), and replace all damaged or fused automatic sprinklers in pilot lines. Restore all manual emergency stations (Model A) and breaking glass stations to their closed positions. Replace all fused thermostats on the electrical system.
6. Hidromatic deluge valve and operating systems are in the normal set position. Open 1/4-in. globe valve (9, in Fig. 222) to admit water supply pressure into the differential unit on the deluge valve.

7. Remove the test plug (DUF-5C, in Fig. 1 and 6DUF-SC, in Fig. 220) to check for leakage at the differential unit disc (6DUF-4, or DUF-4). If no leakage, replace the test plug.
8. Slowly open the main water supply valve (13, in Fig. 222) and the 2-in. drain valve (4, in Fig. 222) when water flows. No leakage or flow should continue through the automatic drain valve (3, in Fig. 222) when the Hidromatic deluge valve is properly set.
9. Open the main water supply valve (13, in Fig. 222) fully and lock in position.

TESTING ALARM

The following test procedure applies to the Hidromatic Deluge Valve with the primary trim, which includes the provision for the waterflow test of the mechanical water motor alarm or electrical pressure alarm switch devices. The testing of either or both of these alarm devices should be done prior to closing the main water supply valve.

1. Open the alarm test valve (5, in Fig. 222) which admits water into the alarm line. Alarm should operate.
2. Close this valve tightly when test has been completed.

If a strainer is installed in the $\frac{3}{4}$ -in. line to the alarm device, it is suggested that the strainer screen be removed and inspected. Clear the strainer screen and body of all sludge and foreign matter before conducting test.

Drainage of the alarm piping after test occurs automatically through a small hole in the body of the check valve.

INSPECTION

1. Carefully check that all controlling valves in the system are open and sealed.
2. Make sure the $\frac{1}{4}$ -in. Globe valve (9, in Fig. 222) is open, or any other $\frac{1}{4}$ -in. valve from water supply to differential unit is open for normal operation.
3. Close the main water supply valve (13, in Fig. 222).

Note: Failure to do so will result in tripping the Hidromatic deluge valve when the pressure is relieved in the chamber of the differential unit.

4. To clean the strainer (10, in Fig. 222), close the $\frac{1}{4}$ -in. Globe valve (9, in Fig. 222), remove the strainer plug and slightly open the $\frac{1}{4}$ -in. Globe valve (9, in Fig. 222) to flush the strainer. Remove the strainer screen, if required, then replace screen and plug.
5. Push inward on the spring-loaded manual drain pin of the automatic drain valve (3, in Fig. 222) to be sure this valve is open and that the body of Hidromatic valve has been drained.
6. Repeat steps 6 through 8 in the section **SETTING THE VALVE**.

Note: When it is necessary to shut off the water supply to the piping upstream of the Hidromatic valve, the main water supply valve (13, in Fig. 4) controlling flow to the deluge valve should be closed. (The *valve shut* tag procedure should be followed.) If this is not done, and if the check valve in the supply line to the differential valve chamber should leak, this chamber will lose pressure, freeing the deluge valve clapper. With the manual control valve shut, restoration of the upstream pressure also restores any lost pressure in the differential valve chamber; then the manual control valve should be reopened and locked open.

4.13 Star Model G Hidromatic

Deluge and Preaction Sprinkler Systems

Star Model "G" 3 In. (7.6 cm) and 6 In. (15 cm) Hidromatic Deluge Valves

Star Model "AA-R" Actuator

INTRODUCTION

The Star Model G deluge valve is approved as a unit for use in controlling the flow of water to special extinguishing systems. The valve can be used with sprinklers, spray nozzles or mechanical foam-making equipment when supervised as required for supervised deluge or preaction systems. These valves have a 175 psi (1206 kPa, 83 bar) rated working pressure.

As always, Factory Mutual approved equipment and components should be used where applicable.

OPERATION (Figs. 223 and 224)

These valves work on the differential pressure principle.

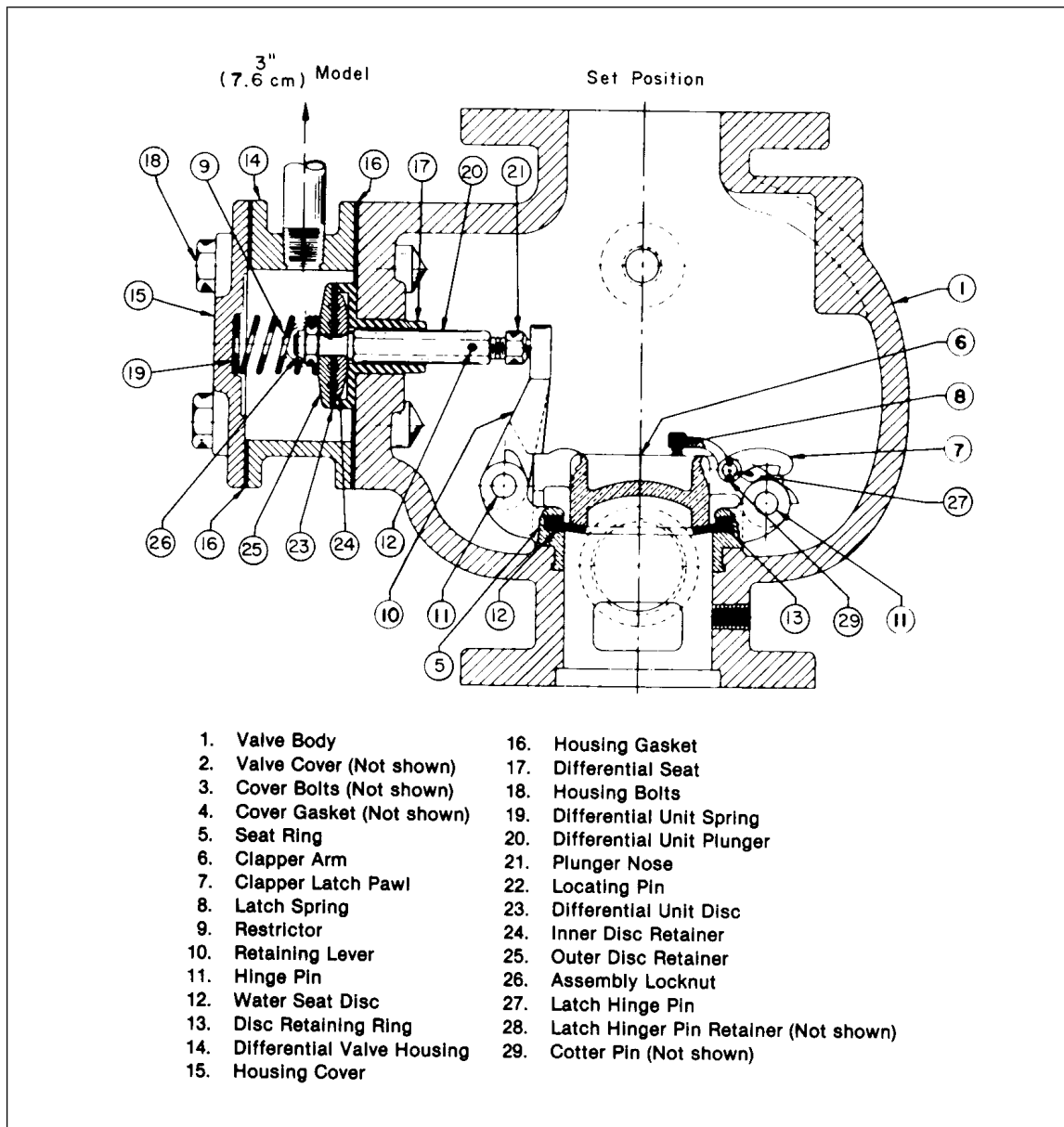

Fig. 223. Star Model G-3-inch (7.6-cm) Hidromatic deluge valve.

Water pressure is maintained in the differential unit (14) through a $\frac{1}{8}$ in. (0.32 cm) inlet orifice in the restrictor (9) connected to a line from the area below the main supply valve. This pressure acts on the disc plate (23) to transmit force through the plunger (21) to the lever (10) which holds the clapper arm (6) in a closed position.

Basic operation of the valve is caused when pressure is released through the pilot line from the differential unit (14) faster than it can enter the $\frac{1}{8}$ in. (0.32 cm) inlet. This causes the plunger (21) to move, removing the force on the lever (10). The water pressure on the supply side is great enough to open the clapper. Once the clapper is open it is held open by the latch (7).

Release of pressure from differential unit and consequent operation of the deluge valve may be accomplished by any of the methods under "Additional Methods of Tripping Deluge Valve." The following is a description of automatic operation using the AA-R pilot line actuator.

MODEL AA-R PILOT LINE ACTUATOR (Fig. 225)

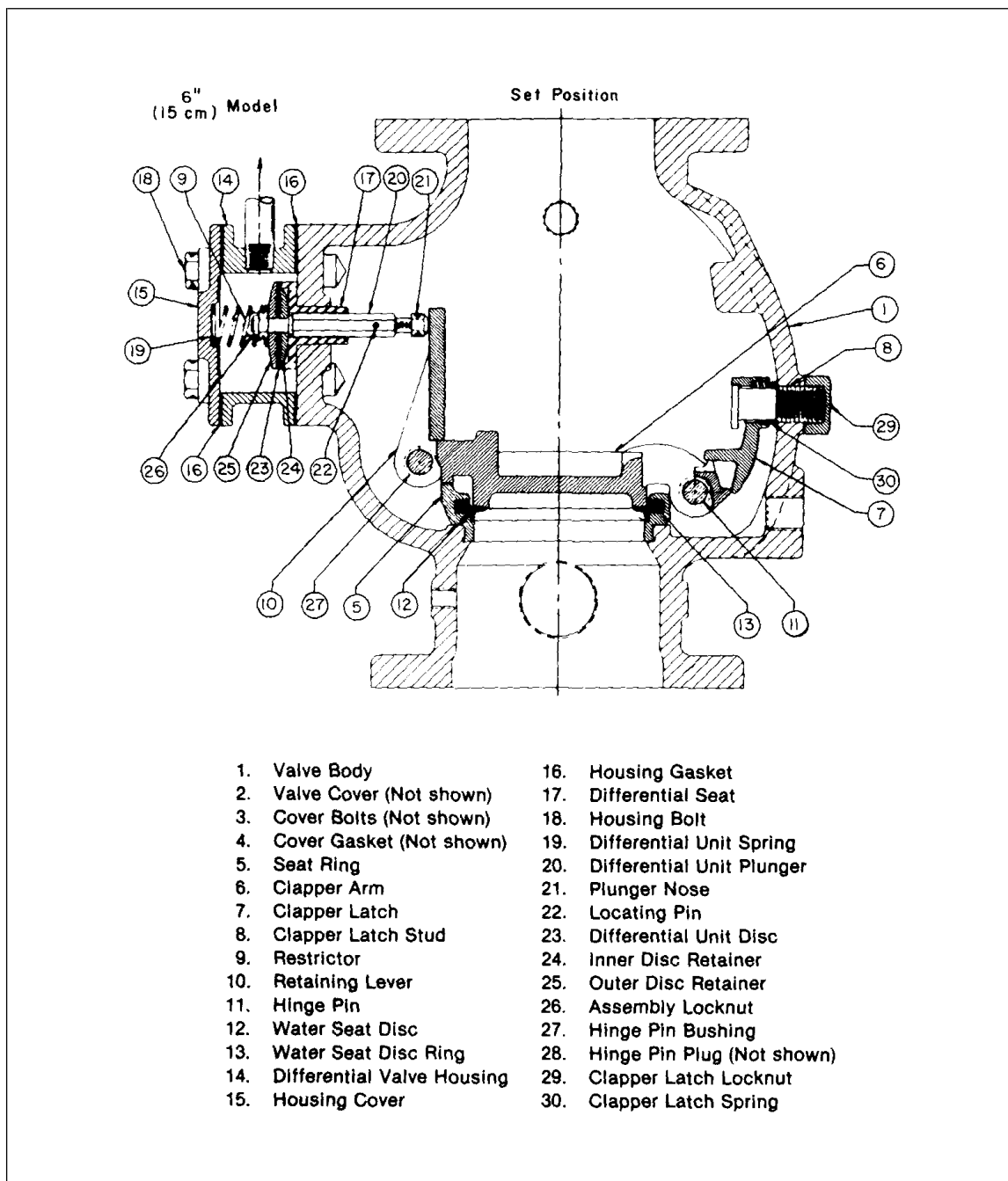

Fig. 224. Star Model G 6-inch (15-cm) Hidromatic deluge valve.

The AA-R actuator is connected on the lower side to the pilot line of the differential unit. On the upper side, it is connected to a pilot line system of automatic sprinklers and pressure maintenance device (Fig. 225).

Pressure supplied by air or nitrogen at approximately 30 psi (206 kPa, 2.07 bar) on the dry side of the actuator prevents discharge of water from the differential unit. When the air or nitrogen pressure is released, the diaphragm (3) moves, allowing the water in the differential unit to escape through the drain in the actuator. The relief of pressure in the differential unit causes the deluge valve to trip. Release of gas or air pressure may also be accomplished by operation of a manual emergency station installed on the pilot line.

PILOT LINE PRESSURE SUPPLY

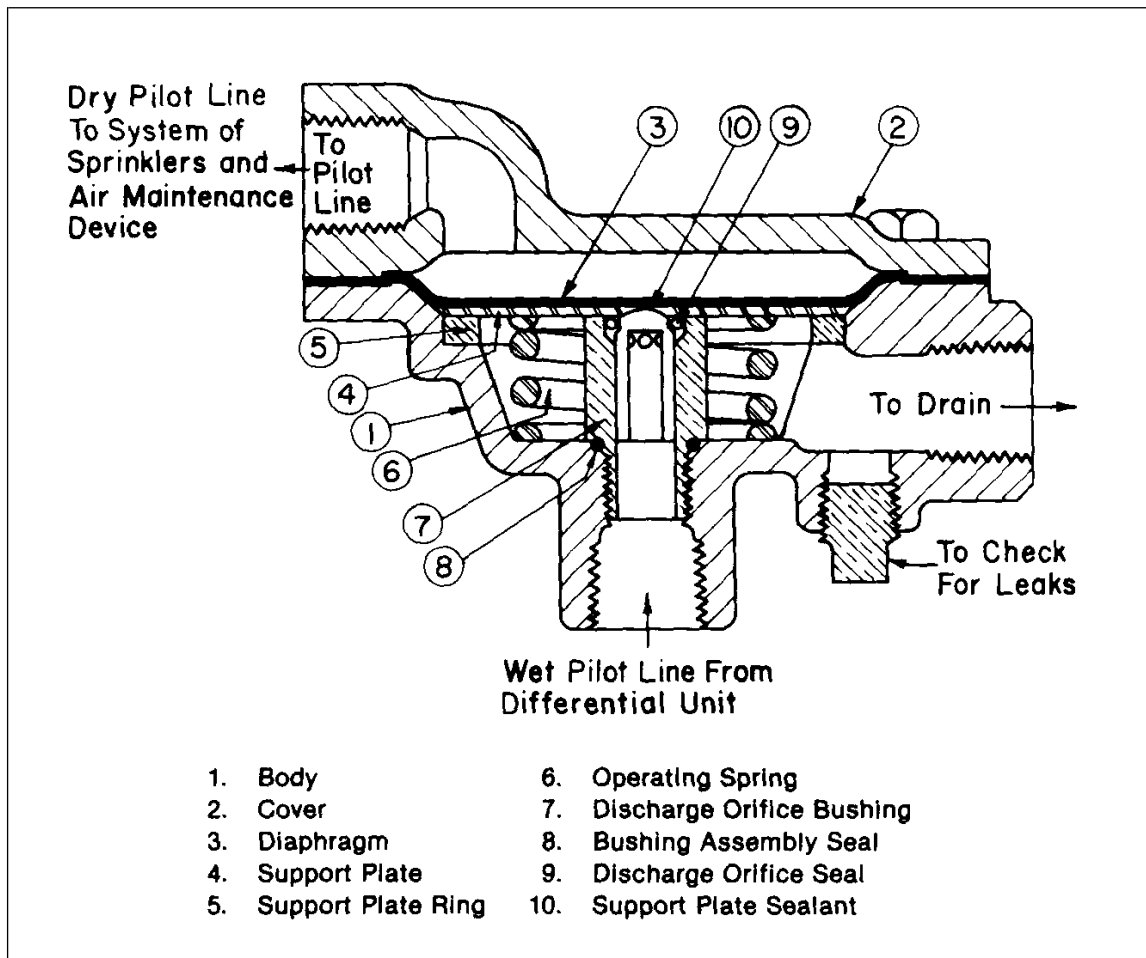

Fig. 225. Star Model "AA-R" actuator.

Nitrogen Cylinder (Fig. 226)

Nitrogen pressure is controlled by a nitrogen regulator set at 30 psi (206 kPa, 2.07 bar).^{*} The pressure relief valve is set at 100 psi (689 kPa, 6.89 bar). The ¼ in. (0.64 cm) restricted check valve limits the nitrogen supply to assure reliable operation of the actuator. A pressure alarm switch is installed to announce pressure variations in the pilot line.

^{*}For system water pressure above 80 psi (551 kPa, 5.51 bar) refer to Figure 5 for pressure required in dry pilot line.

Owner's Air Supply or Shop Air Compressor

Fig. 228 shows the arrangement for shop air compressor tie-in. A reservoir and soft seat check valve hold a reserve supply of air for the pilot line should the owner's air supply be (temporarily) disrupted. If an individual air compressor is used solely to maintain pressure in the pilot lines, pressure settings are 27 psi (186 kPa, 1.86 bar) for turn-on, 30 psi (206 kPa, 2.07 bar) for shut-off.^{*} The compressor should be of sufficient capacity to pressurize the pilot line to 20 psi (138 kPa, 1.38 bar) in 30 minutes or less. This arrangement also provides a pressure alarm switch.

ADDITIONAL METHODS OF TRIPPING DELUGE VALVE

Automatic

1. *Electric heat detectors which trip a solenoid valve* (Fig. 229). When the solenoid valve is tripped, the water is released through a drain and the pressure released from the pilot line and differential unit.

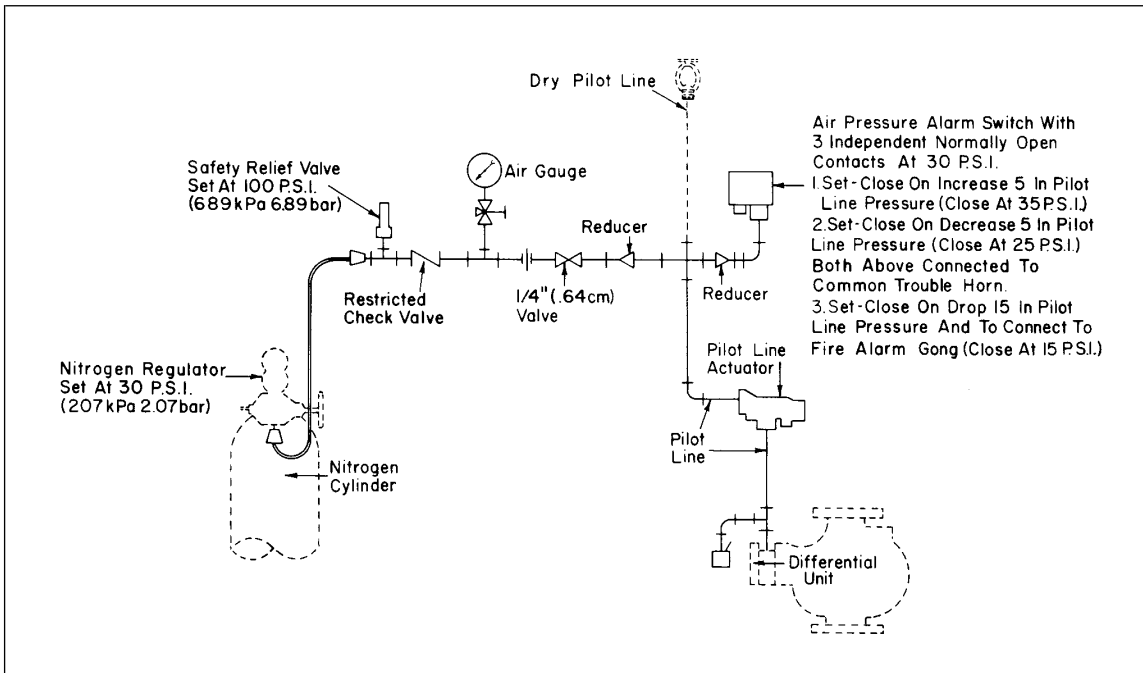

Fig. 226. Component arrangement for dry pilot line - automatic maintenance using nitrogen as the pressurizing agent.

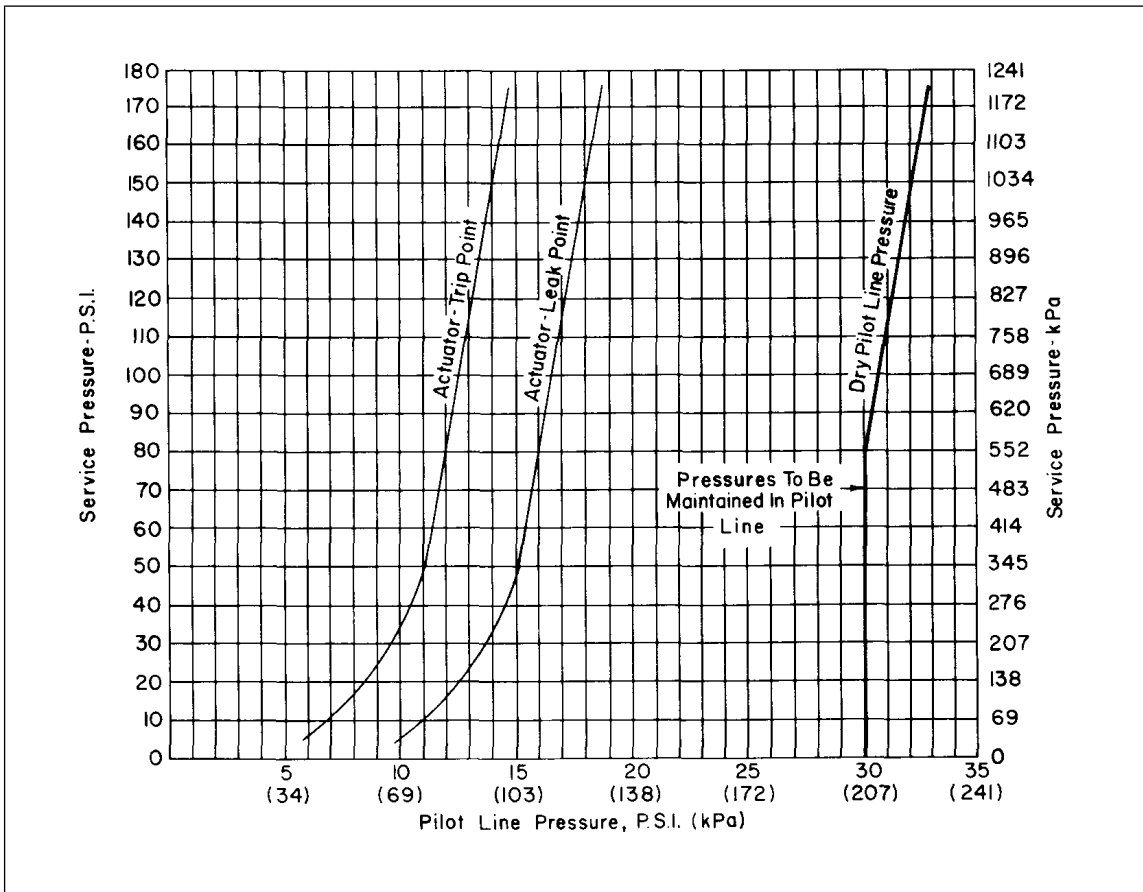

Fig. 227. Air pressure to be maintained in dry pilot based on system water pressure. Air pressure alarm switch provides two sets of normally open contacts, at 30 psi: #1 set, to trouble horn, drop of 5 psi: (close at 25 psi); #2 set, to fire alarm gong, drop of 15 psi (close at 15 psi).

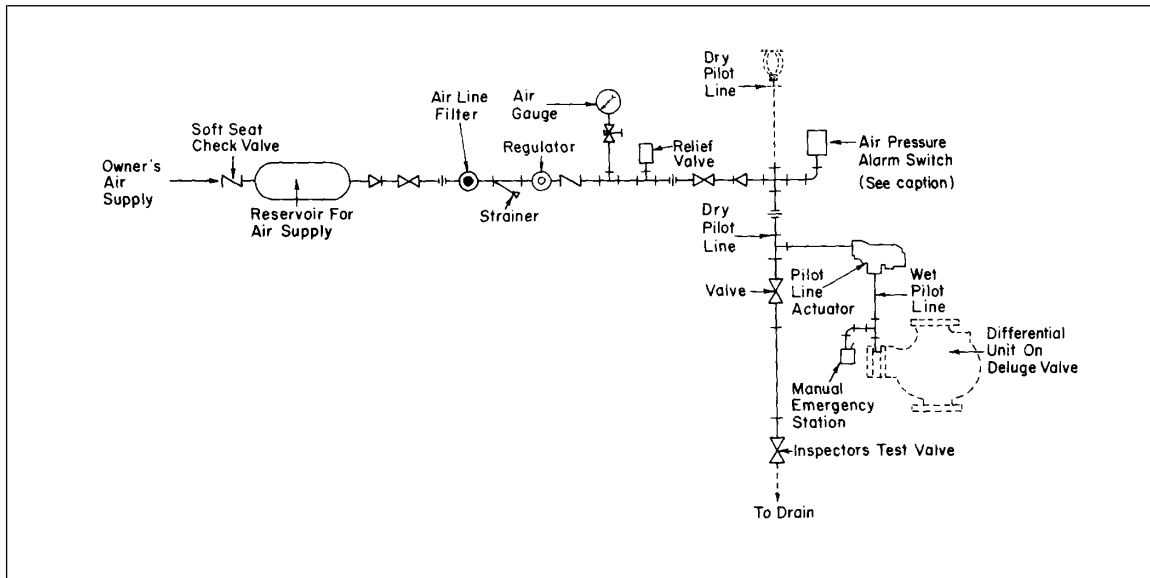

Fig. 228. Component arrangement for dry pilot line - automatic air maintenance - using owner's air supply as source.

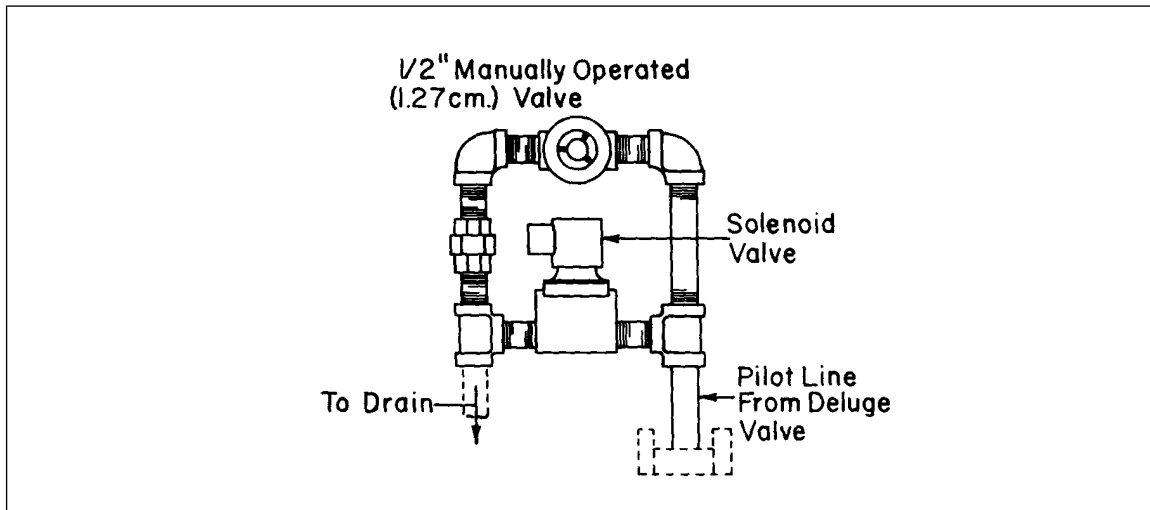

Fig. 229. Electrical operation with provision for manual operation at deluge valve location.

2. *Wet pilot line with automatic sprinklers* (Fig. 230). The water in the pilot line and differential unit is released when the sprinklers fuse and open, causing the valve to trip. Table 28 gives the maximum distance the pilot line sprinklers may be located above the deluge valve for proper operation.

3. *Supervised preaction system* (Fig. 231-A and B). The operation of the valve in the preaction system is the same as in the deluge system except that devices are added to provide for supervisory air pressure in the sprinkler piping. In the preaction system air pressure between 2.5 psi (17 kPa, 0.17 bar) and 4 psi (27 kPa, 0.27 bar) is maintained in the sprinkler system piping. This pressure is supervised by a low pressure supervisory switch. Operation of the deluge valve is accomplished by any of the methods stated to release air pressure from the pilot line. The low pressure supervisory air switch is connected to a trouble horn, light, etc. A check valve is located above the deluge valve to confine supervisory air pressure. An air pressure relief valve set at 10 psi (69 kPa, 0.69 bar) prevents excessive pressure in sprinkler piping. Check valves protect the air pressure controls and compressor from high water pressure when system operates.

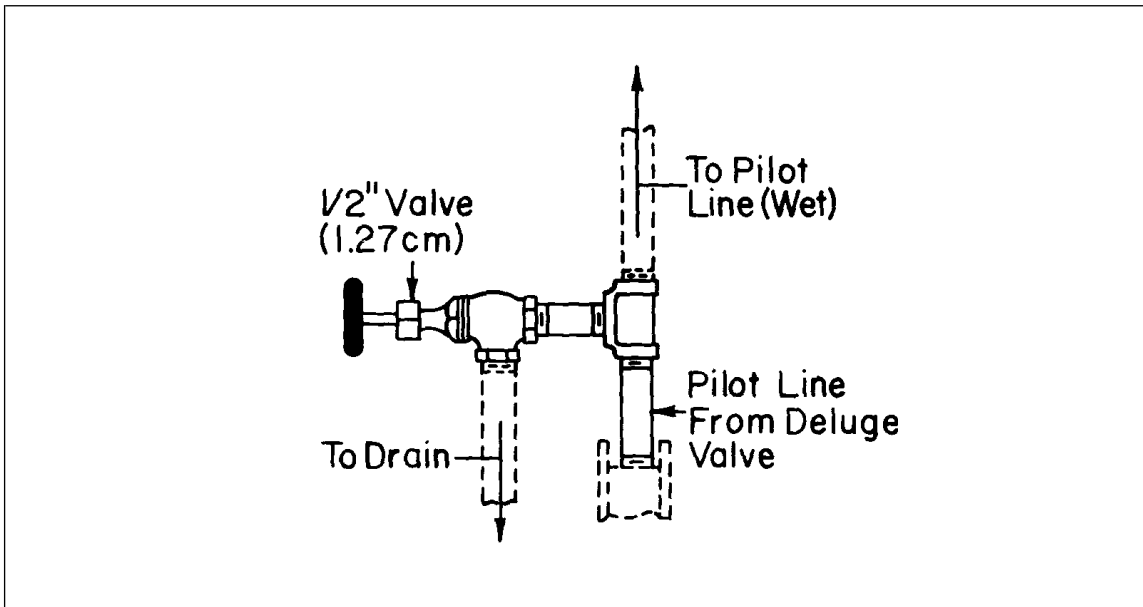

Fig. 230. Wet pilot line operation - with valve for manual or system testing.

Table 28. Maximum Distance of Pilot Line Sprinklers Above Deluge Valve.

Water Supply Pressure			Maximum height of pilot sprinklers above deluge valve for:			
psi	kPa	bar	3 in. (7.6 cm)		6 in. (15 cm)	
			ft	m	ft	m
20	138	1.38	5	1.5	4	1.2
40	276	2.76	7	2.1	12	3.7
60	414	4.14	10	3.0	21	6.4
80	551	5.51	12	3.7	29	8.8
100	689	6.89	17	5.2	37	11.3
120	827	8.27	21	6.4	46	14.0
140	965	9.65	27	8.2	54	16.5
160	1103	11.03	37	11.3	62	18.9
175	1206	12.06	54	16.5	68	20.7

Remote Manual Trip

1. Break glass manual emergency station connected in the electrical circuiting of heat detectors.
2. Manual emergency station connected to the pilot line on a supervised pipeline (Fig. 232).

Manual Trip

1. Manually operated 1/2 in. (1.27 cm) valve at deluge valve (Fig. 229).
2. Push-button on valve housing.

SETTING (or Resetting)

Steps 1-5 refer to Figs. 233 and 234.

Steps 6-14 refer to Figs. 223 and 224.

1. Close valve controlling water supply to the system (1).
2. Close 1/4 in. (0.64 cm) valve (2) in the water supply line to the differential unit chamber.
3. Open the main drain valve and allow system to drain.

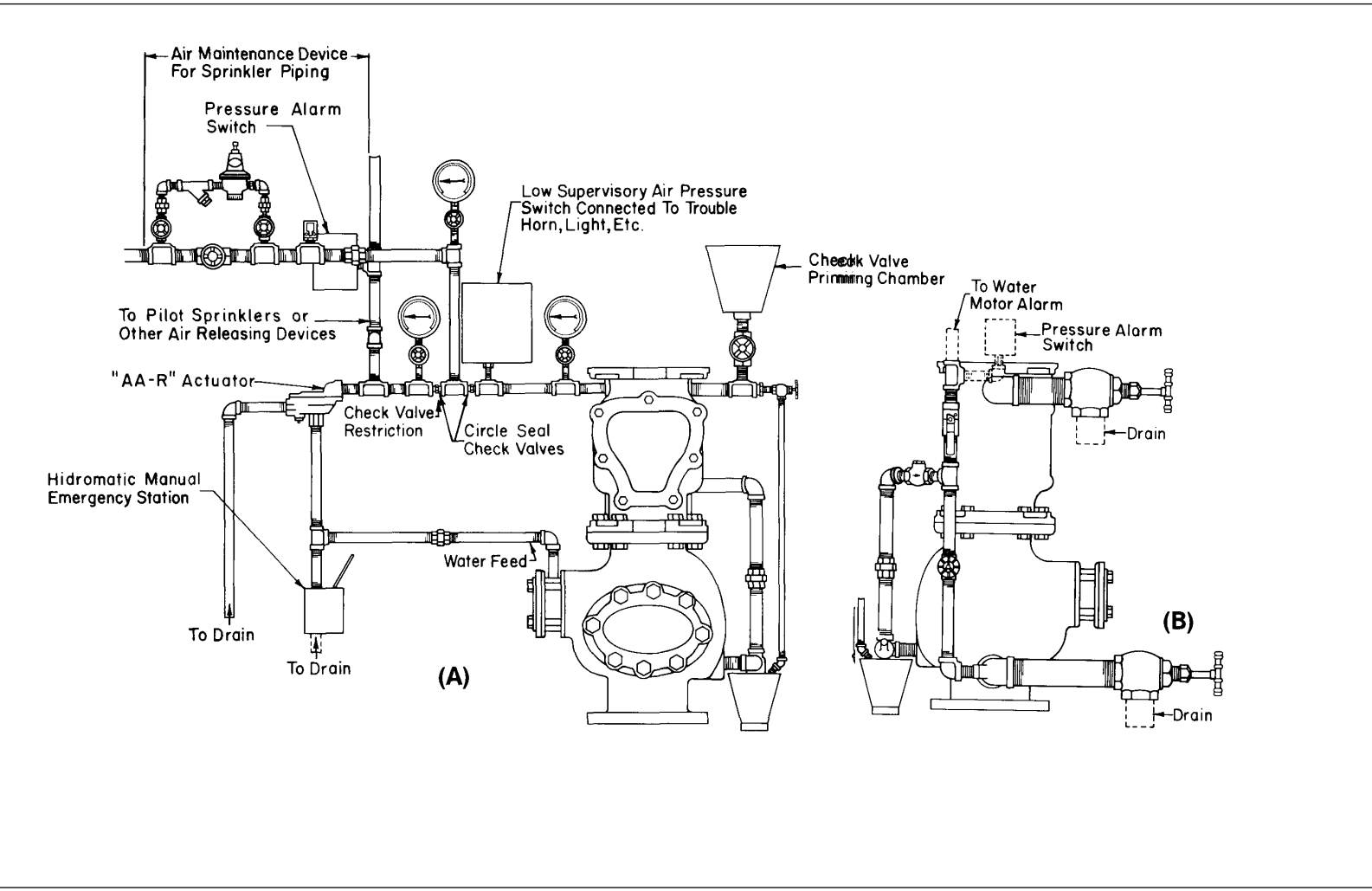

Fig. 231. Supervised preaction system. Methods of operation: (1) automatic pilot sprinklers, (2) Model A Hidromatic manual emergency station, or (3) any other means of releasing air pressure from pilot sprinkler piping.

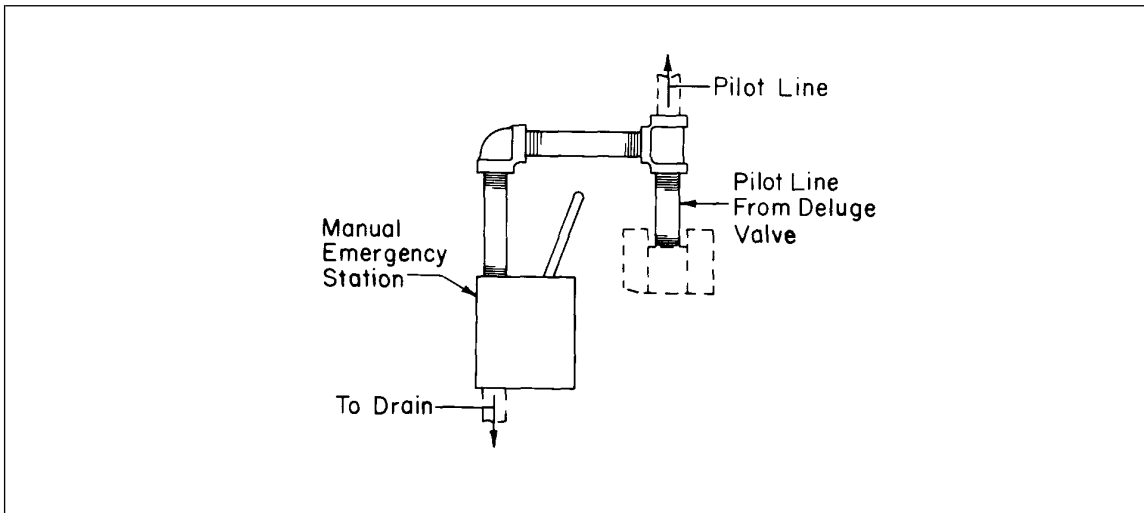

Fig. 232. Wet pilot line operation manual emergency station for manual or system testing.

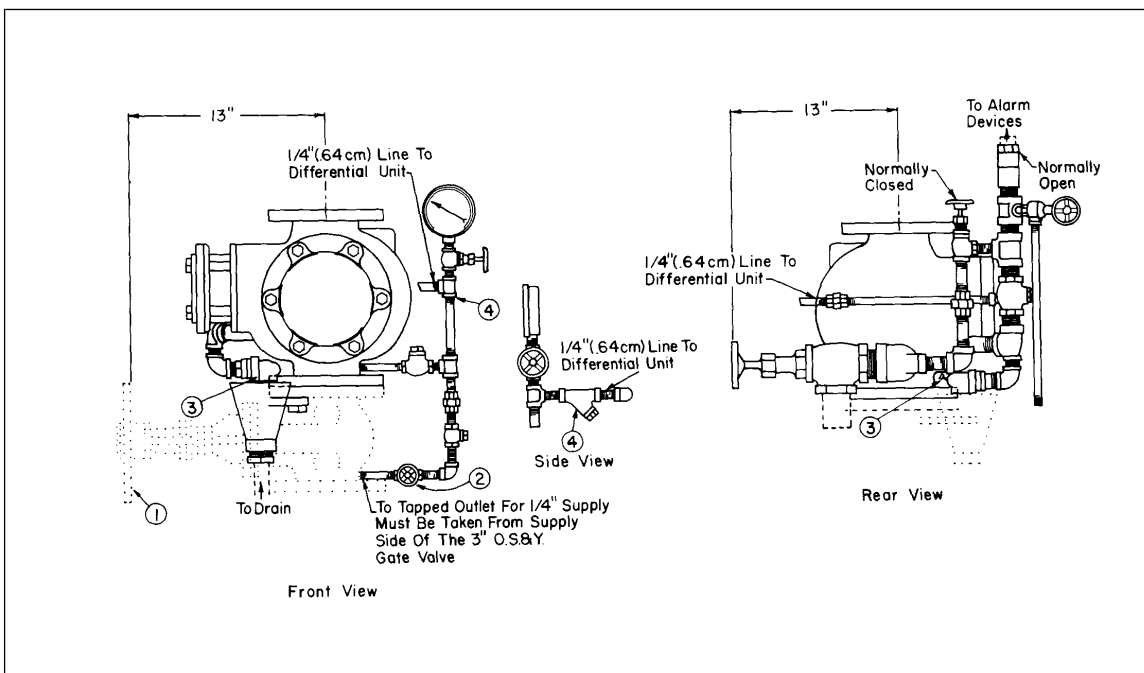

Fig. 233. Three-inch (7.6 cm) model. Whenever possible, run 1-inch drain line from drain cup separately to outside or sewer. If absolutely necessary to unite 1-inch drain line into 1 1/2-inch main drain line, this connection must be made 4 feet or more below top of drain cup, with a check valve installed in the 1-inch drain line.

4. Open auxiliary drain valve to drain alarm line, and all other auxiliary drain valves and/or plugs at all low points in the system. Close when water has ceased to drain.
5. Push inward on spring-loaded manual drain pin of the automatic drain valve (3) to be sure this valve is open and that the body of the Hidromatic valve has been drained.
6. Remove the valve cover. Carefully wipe clean water seat disc (12), seat ring (5), seating surface and nose of clapper arm and machined boss on seat ring. Make sure all hinging is free. Retaining lever (10) should move freely to the left, pushing plunger nose (21) on plunger assembly along with it.
7. Remove differential housing cover (15). Do not lose or damage differential unit spring (19).

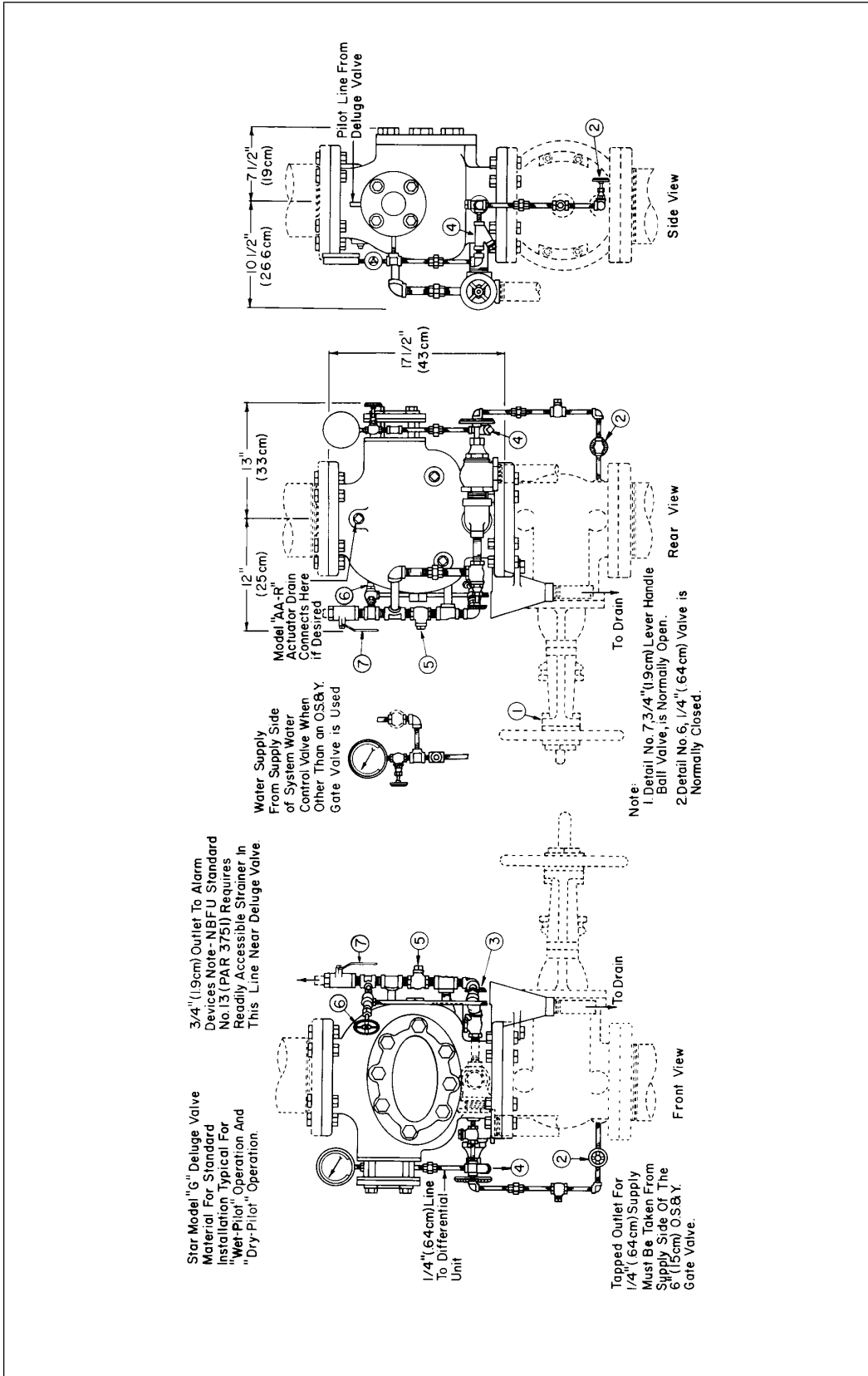

Fig. 234. Six-inch (15 cm) model.

8. Remove plunger assembly for cleaning and inspection. Carefully wipe clean the seating surface on the seat (17).
9. Carefully replace plunger assembly, differential unit spring (19) and housing cover (15). Make sure differential unit spring is in its proper position, over assembly locknut (26) and in housing cover recess.
10. Unlatch and lower clapper arm (6) to the set position with its nose under the retaining lever (10). There is approximately $\frac{1}{16}$ in. (0.16 cm) clearance between plunger nose (21) and the retaining lever (10).
11. Replace valve cover.
12. Close manual test valve. Replace all damaged or fused automatic sprinklers in pilot lines. Restore all manual emergency stations and break-glass stations to their closed positions. Replace all fused thermostats on electrical systems.
13. When the Hidromatic deluge valve and operating systems are in the normal "set" position, open the $\frac{1}{4}$ in. (0.64 cm) valve (2) to admit water supply pressure into the differential unit.
14. Slowly open the main gate and close the main drain valve when water flows. No leakage or flow should continue through the automatic drain valve when the Hidromatic deluge valve is set properly.

MAINTENANCE, INSPECTION, AND TESTS

Refer to Data Sheet 2-81, *Inspection and Maintenance of Sprinkler Systems*. In addition, the following procedures should be followed:

Inspection (Figs. 233 and 234)

1. Check that all controlling valves in the system are open for normal operation.
2. Check that $\frac{1}{4}$ in. (0.64 cm) valve (2) and any other $\frac{1}{4}$ in. (0.64 cm) valve on the water supply line to the differential unit is open for normal operation.
3. Close main supply valve (1).

Note: Failure to do so will result in tripping the Hidromatic deluge valve when the pressure is relieved in the differential unit.

4. To clean strainer (4) close $\frac{1}{4}$ in. (0.64 cm) valve (2), remove strainer plug (4), and slightly open the $\frac{1}{4}$ in. (0.64 cm) valve (2) to flush strainer. Remove strainer screen if required and then replace screen and plug. Open $\frac{1}{4}$ in. (0.64 cm) valve (2).
5. Push inward on spring loaded manual drain pin (3) to be sure that the body of the deluge valve has been drained.
6. Follow paragraphs 6 through 14 of the setting procedure (Figs. 223 and 224).
7. Never apply grease, tallow or any oily substance to the molded rubber water seat disc (12) or the differential unit disc (23).

Testing Alarms

1. Make sure water supply valve is open.
2. If a strainer is installed in the $\frac{3}{4}$ in. (1.9 cm) line to the alarm devices, it is suggested that the strainer screen be removed and inspected. Clear the strainer screen and body of all sludge and foreign matter before conducting test.
3. Open alarm test valve which admits water into alarm line.
4. Close the alarm test valve tightly when test is complete.
5. Drainage of the alarm piping should occur automatically through a small hole in the check valve (5) when the test is complete.

4.14 Viking Firecycle Sprinkler System

Viking Firecycle

On-Off Multicycle Sprinkler System

With Water Control Valves

Model G-1: 2 IN. (51 MM) 1967

Model G-2: 3, 4, 6 IN. (76, 102, 152 MM) 1974

INTRODUCTION

The Viking Firecycle system is basically an electrically controlled sprinkler system which not only turns the water on whenever needed but also shuts the water off when it is no longer needed. It will repeat the “on-off” cycles indefinitely in the event of fire redevelopment.

With this system, there is no need to close the manual control valve to replace the sprinklers opened during a fire or to make repairs to the sprinkler system piping or the electrical detector circuit. The system may be used wherever a wet pipe, preaction, or dry-pipe system would be suitable. It is particularly advantageous in those areas where operations are such that sprinkler pipe breakage is likely. The on-off feature is well suited for those high value occupancies where water discharge should be held to an absolute minimum.

The detection or fire-sensing system includes a Viking Model B-2 or C Series supervisory control cabinet, emergency battery supply and charger, detectors (with normally closed contacts), pressure supervisory and waterflow alarm switches, water-motor gongs, and alarm bells. This detection system automatically controls the hydraulic system to start and stop flow, indicates system damage and power failure, and actuates the fire alarm.

There are two types of Firecycle systems: Models B-2 and C-2 through 12.

Model B-2

The Model B-2 system is designed for single-zone fire detection. The system includes a Model G-1 or G-2 water control valve, Model B-2 control panel and valve trim box, detectors, and an approved waterflow alarm.

Model C-2 through 12

The Model C-2 through C-12 systems are designed for multiple-zone fire detection. The systems include a Model G-1 or G-2 water control valve, Model C control panel and valve trim box, detectors, an approved waterflow alarm, and a zone panel which divides the protected area into 12 or less zones. The suffix numbers (2 through 12) designate the number of zones being used.

The Model C control panel is identical to the Model B-2 control panel, except for wiring changes to the thermal test button which are required for use with the Models C-2 through C-12 zone panels. The Models C and B-2 valve trim boxes and all other components are identical on both systems.

FIRECYCLE OPERATING SEQUENCE

Normal Set Condition (Detection System in Operation, Fig. 235)

In normal set condition, the sprinkler system is pressurized with supervisory air at 10 psi (69 kPa) (0.69b). Water supply pressure holds the clapper of the flow control valve closed and is trapped against the pilot solenoid valves V_1 and V_2 in the valve trim box. Pressure between the flow control valve and the check valve downstream is maintained at atmospheric level by a ball drip drain. Water pressure above and below the flow control valve clapper is equal. Pilot solenoid valves V_1 and V_2 are closed (i.e., energized). Pressure switch PS1 in the valve trim box and the detection circuit are closed.

Set Condition (Detection System Not in Operation)

If the detector circuit is damaged, relays CR1 and CR2 (20 and 21, Fig. 236) will de-energize, operating the fire alarm and timer circuit and opening solenoid valves V_1 and V_2 (18, Fig. 236) just as though the detectors had operated under a fire condition. To maintain protection while the detector circuit is being repaired, the control system should be switched to LOSS IN SYSTEM PRESSURE operation, as follows:

1. Press and hold the reset button (5, Fig. 240) and turn the Firecycle selector switch (3, Fig. 240) to OFF.
2. Drain the system piping.
3. Admit air to system piping to establish a pressure of 10 psi (69 kPa) (0.69b).

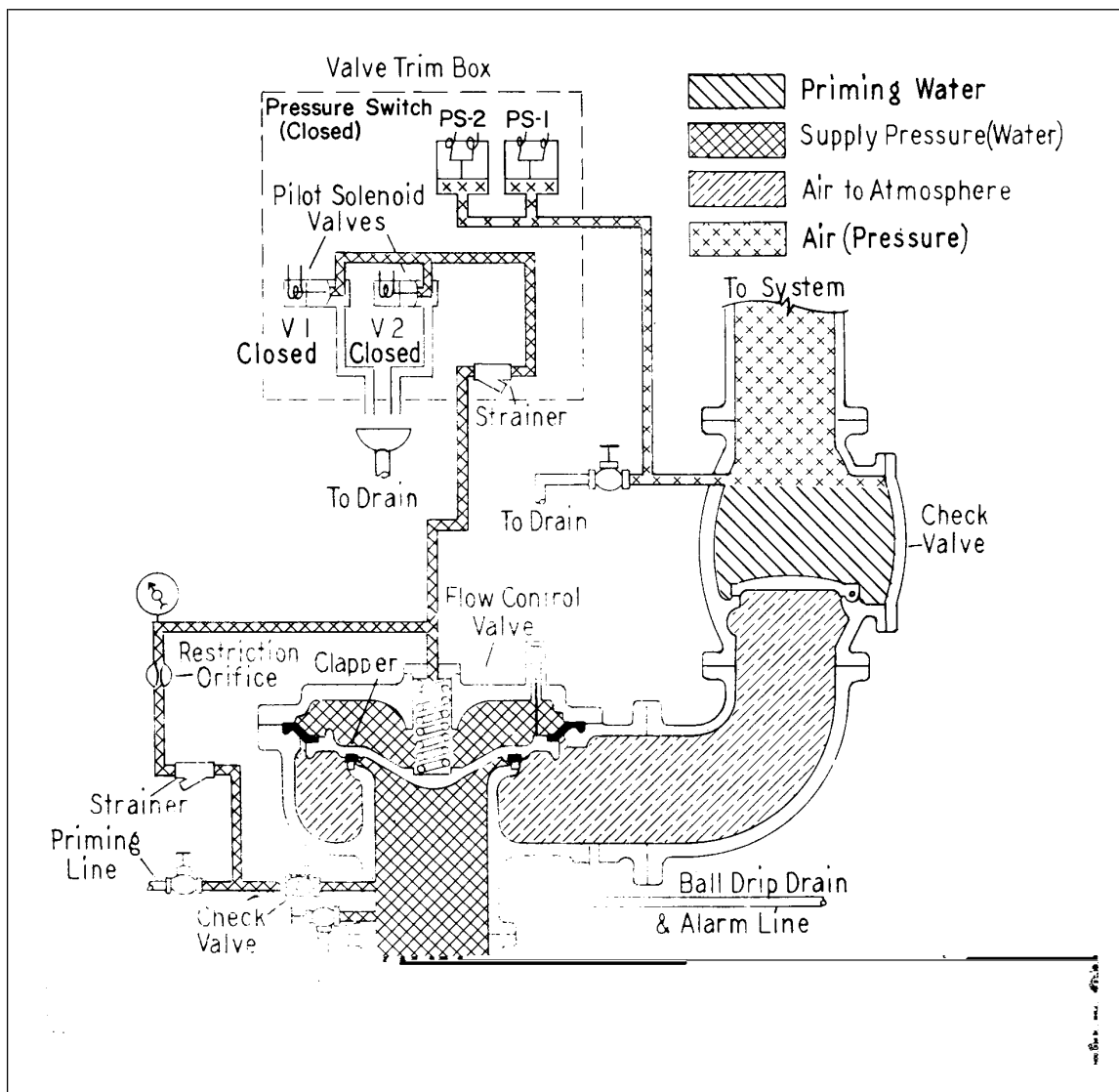

Fig. 235. Normal set condition (valve closed).

4. Return alarm control switch (2, Fig. 240) to ON. Pressure switches PS1 and PS2 (17, Fig. 236) and solenoid valves V_1 and V_2 (18, Fig. 236) are closed, and pressure above and below the flow control valve clapper is equal. The system will now act as a dry-pipe sprinkler system.

Operation Due to Fire (Detection System in Operation, Fig. 237 and 238)

1. When the temperature increases, a Firecycle detector(s) opens (de-energizes) relays CR1 and CR2 (20 and 21, Fig. 236). This causes:

- a. Pilot solenoid valves V_1 and V_2 to open, allowing water to drain from above the clapper and causing the clapper to open and admit water to the sprinkler system.
- b. Relay CR2 (21, Fig. 236) contacts to close the circuit to the fire alarm.
- c. Relay CR1 (20, Fig. 236) contacts to complete the circuit from the timer to the detector circuit (which is now open).

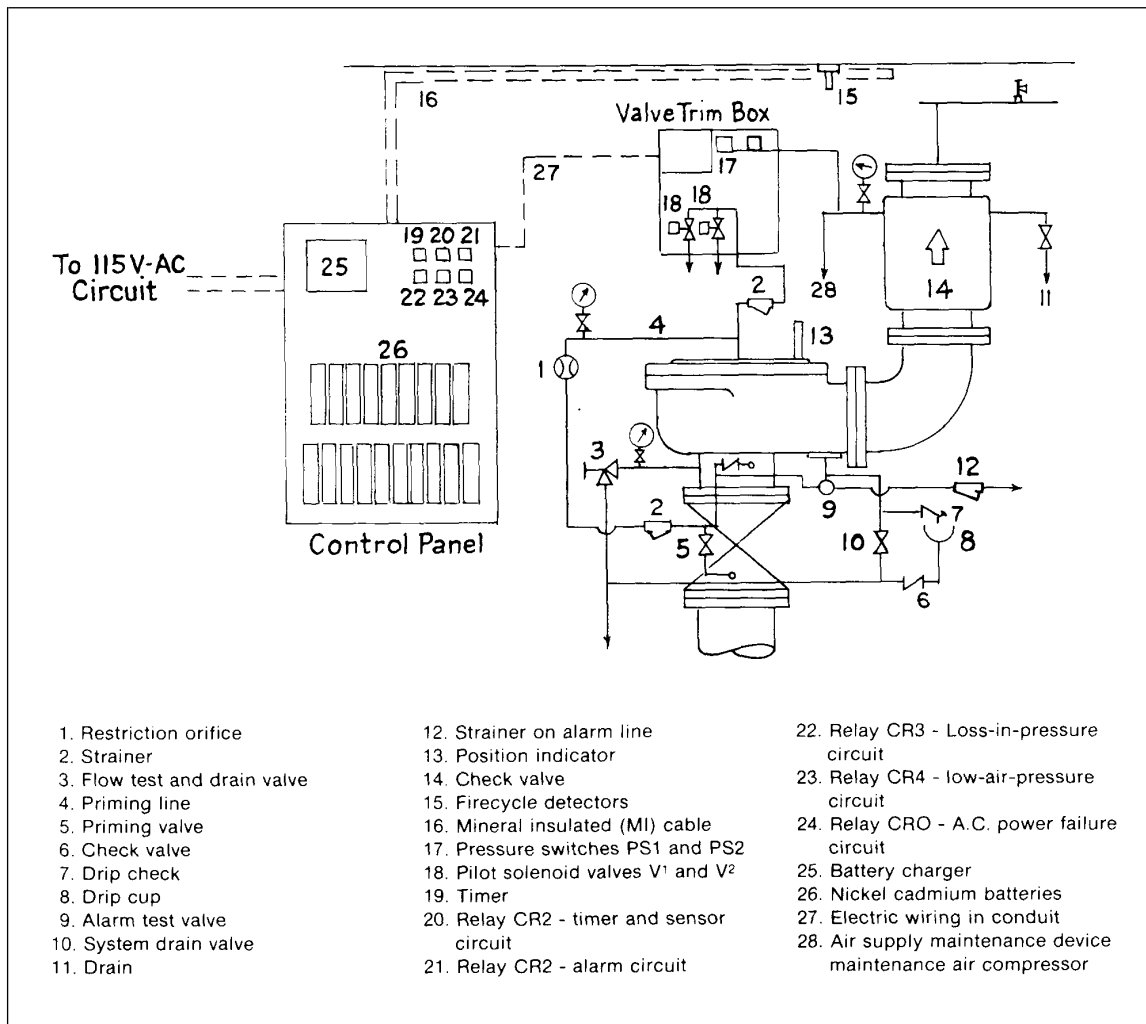

Fig. 236. Viking Firecycle system schematic.

2. When the temperature decreases to a predetermined point, the detector(s) return to the closed position and complete(s) the timer circuit through the contacts of relay CR1 (20, Fig. 236). The timing cycle starts and, after a predetermined interval, the timer contacts complete a circuit to close pilot solenoid valves V₁ and V₂.

3. Pressure builds above the clapper of the flow control valve which closes and shuts off the sprinkler water supply (Fig. 238).

4. At this point, even though the water is shut off at the flow control valve, the system stands ready to open the flow control valve and repeat steps 1 through 3 if the detectors sense another temperature increase.

5. The fire alarm will continue to operate until the alarm control switch (2, in Fig. 240) is turned to the OFF position and the system is reset.

Operation Due To Fire (Detection System Not In Operation, Fig. 236)

1. When the temperature increases sufficiently, a sprinkler opens. This releases air pressure in the sprinkler system.

2. Pressure switch PS2 (17, Fig. 236) opens, sounding the low air pressure alarm when the pressure reaches 8 psi (55 kPa) (0.55b).

3. Pressure switch PS1 (17, Fig. 236) opens when the system air pressure reaches 7 psi (48 kPa) (0.48b), de-energizing relay CR3 (22, Fig. 236).

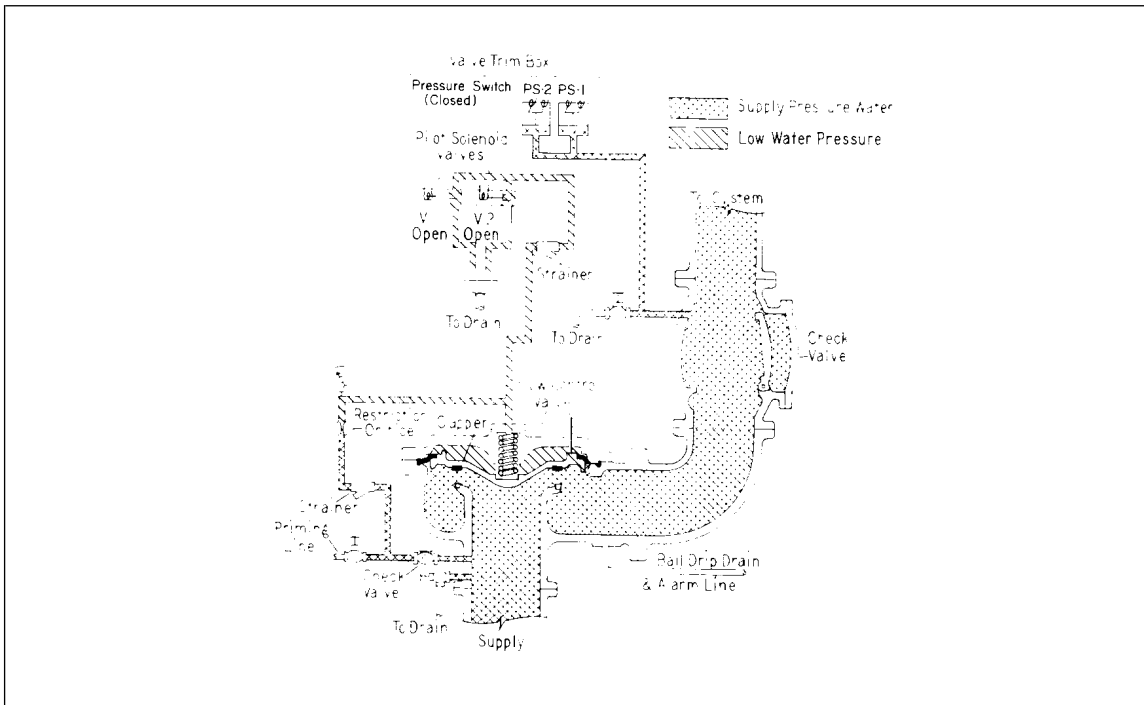

Fig. 237. Operating condition (valve open).

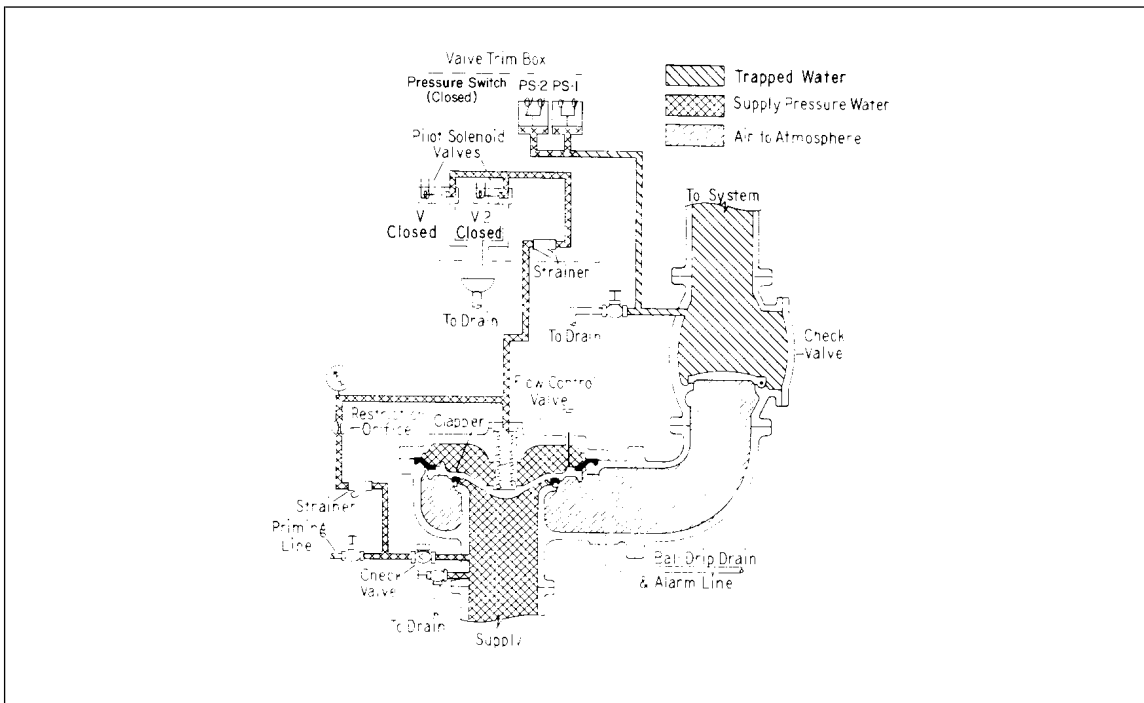

Fig. 238. Cycle end condition (valve closed).

4. Contact CR3 (22, Fig. 236) opens, de-energizing relays CR1 (20, Fig. 236) and CR2 (21, Fig. 236) and pilot solenoid valves V₁ and V₂ (18, Fig. 236). These valves open and vent the top of the flow control valve, allowing the clapper to open and admit water to the sprinkler system.

5. The water motor gong or other flow alarm operates when the flow control valve clapper opens.

6. Water continues to flow through the system until shut off manually.

Resetting to Normal Set Position (Detection System in Operation)

NOTE: DO NOT SHUT OFF THE MANUAL WATER CONTROL VALVE.

1. Turn alarm control switch (2, Fig. 240) OFF.
2. Completely drain water from sprinkler system.
3. Replace all open sprinklers.
4. Admit 10 psi (69 kPa) (0.69b) air to sprinkler system.
5. Press reset switch (5, Fig. 240). The fire alarm will now operate if the electrical system is functioning properly. But the alarm control switch is in the OFF position. Turn the alarm control switch to ON to turn the alarm off.
6. Check detectors in the fire area as outlined in the detector section.

COMPONENT DESCRIPTION

Flow Control Valve

The Model G-2 (Fig. 239) has a slightly different clapper assembly: a rubber diaphragm and molded rubber seat ring. Otherwise, the Models G-1 and G-2 valves are the same. The clapper is held closed by pressure supplied through a restricted, external filling line. When the top chamber is vented (by opening pilot solenoid valves V_1 and V_2 faster than pressure can be made up through the restriction orifice (Fig. 237, 238), the clapper opens. If pilot solenoid valves V_1 and V_2 close, pressure again increases in the top chamber. This pressure plus the added spring pressure cause the clapper to close. The approximate differential is 2:1.

Model B-2 Control Cabinet

The Model B-2 control cabinet (Fig. 240) contains the power supply timer, relays, and other components required for operation of the system. On the side of the cabinet are two condition indicator lights and four control switches arranged vertically. From top to bottom, they are: alarm control light, alarm control switch, Firecycle selector switch, thermal test switch, reset switch, and Firecycle light.

Power Transformer and Battery Charger

The power transformer and battery charger converts 115 V ac to 24 V dc to operate the system normally and to charge the batteries. Battery charging rate is controlled by changing the voltage output with the continuously variable transformer control.

Timer

The timer allows water to flow for a specified time after ceiling temperature drops below the operating temperature of the detectors, normally 140°F (60°C). Maximum time (standard timer) is 5 minutes. The timer is factory adjustable only.

Batteries

The batteries are designed to supply power for 96 hours should the 115 V ac supply fail.

Viking Model B-2 Valve Trim Box

The Model B-2 valve trim box (Fig. 241) contains pilot solenoid valves, pressure switches, and strainer. Pilot solenoid valves V_1 and V_2 are closed when energized. There are two pressure switches. PS2 controls the low air pressure alarm bell. PS1 operates the system when the Firecycle Selector Switch 3 (Fig. 240) is turned to the OFF position.

Viking Model A Detector

The Model A detector (Fig. 242) has a sensing portion 3 in. (76 mm) long and $\frac{5}{8}$ in. (16 mm) in diameter. The outer tube is of stainless steel and contains an internal assembly made from material having a low coefficient of expansion. The outer tube itself has a high coefficient of expansion. A rise in the temperature of the surrounding air will cause the tube to expand faster and to a greater extent than the internal parts. This will open contacts when the surrounding air reaches the temperature for which the detector is set. This detector is designed to withstand very high temperatures for a short period of time. A guard is provided, as

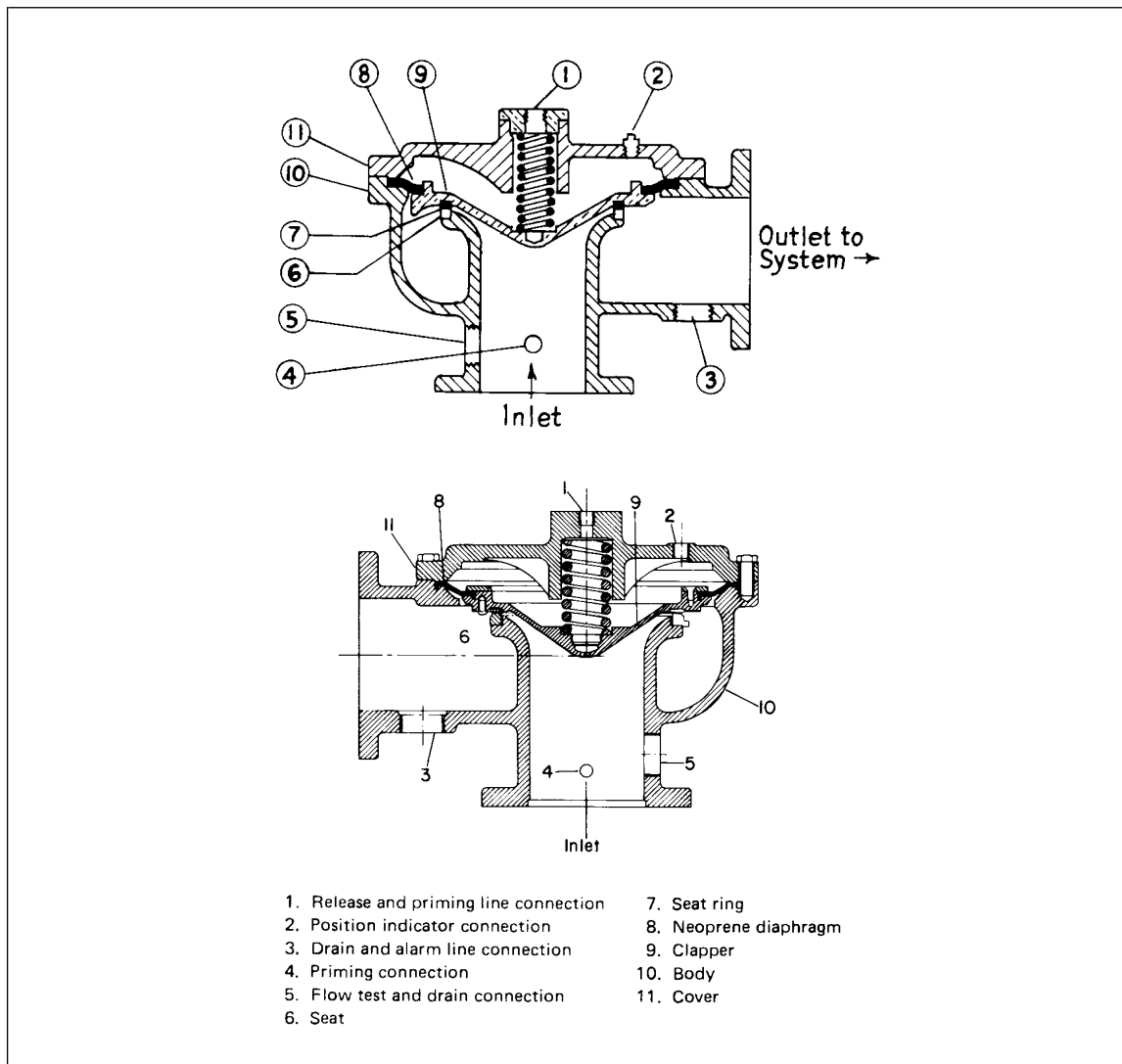

Fig. 239. Viking flow control valve. Model G-1 (upper) and Model G-2 (lower).

an integral part, to protect the sensing element during installation and testing. Also, a tell-tale detector which operates at 800°F (427°C) is included on every unit. This gives visual indication that the detector has been subjected to high temperatures and should be replaced.

Cable and Connector

The mineral-insulated (MI) cable and plug-type connector (Fig. 243 and 244) are designed for ease of installation. They are designed to resist physical damage and high temperature. Connectors are furnished and installed by the cable manufacturer. Each unit is vacuum tested to ensure an air- and moisture-tight seal.

INSTALLATION

The Firecycle system should be installed in accordance with the current standard(s) on installation of sprinkler systems, except as modified here.

For water demand purposes, this system should be treated the same as a dry-pipe system.

This system should only be installed by the manufacturer or his licensee.

Each riser should be equipped with a check valve (14, in Fig. 236), and should have independently supervised air pressure.

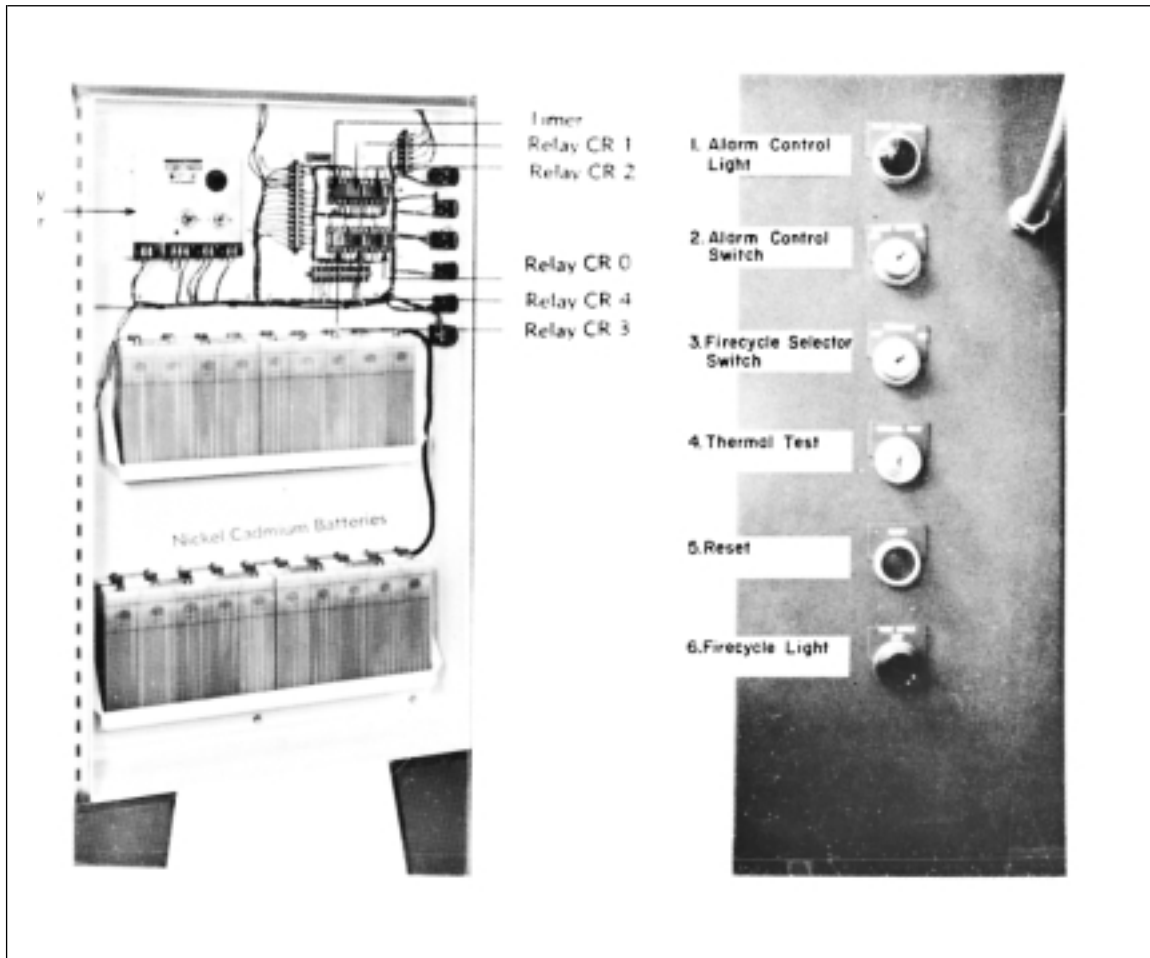

Fig. 240. Control cabinet, Model B-2.

Detectors

1. The detector should be adequately supported and located at the same elevation as the sprinkler head (Fig. 245).
2. The detector should be located from 12 to 18 in. (305-457 mm) horizontally from the sprinkler.
3. With standard upright sprinklers, the detector may be attached to the sprinkler pipe with U-bolts. This allows the MI cable to run parallel to and be supported by the piping. The detector should be mounted on top of the pipe so that the sprinkler deflector and the detector shell are at the same elevation.
4. The detector should be electrically connected by plugging the cable ends into the mounting sockets of the detector and then tightening the nuts of the compression fitting.
5. Since connectors must be applied at the factory, the cable should be ordered in exact lengths. The cable should form a continuous series loop between the control cabinet and detectors. The cable should be ordered a minimum of 2 ft (0.6 m) longer than the distance between the detectors, or between the detector and the control cabinet, to facilitate installation and to allow for expansion and contraction of the cable. Vertical differences and any detours should be considered when specifying cable lengths.
6. A detector can monitor a maximum floor area of 1600 sq ft (149 m²) inside buildings. Detectors should not be spaced more than 40 ft (12 m) apart. Spacing between detectors and walls or partitions should not exceed 20 ft (6 m). With these parameters, the detector will operate before a 160°F (71°C) sprinkler located on a 10 × 10 ft (3 × 3 m) spacing.

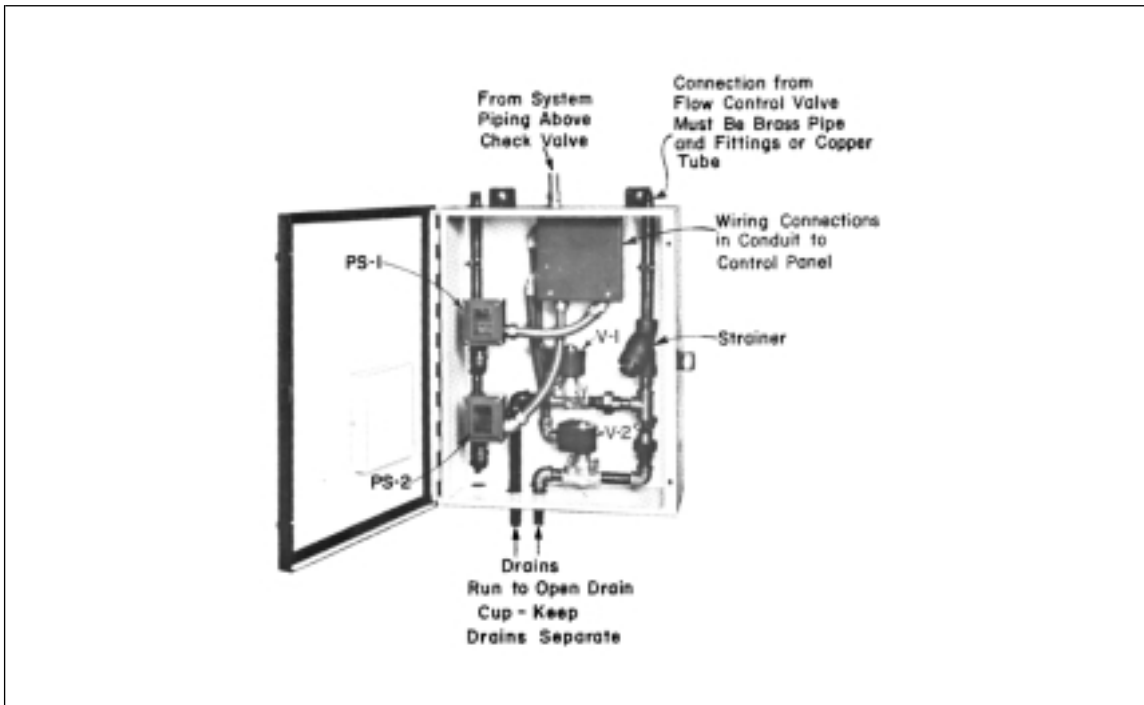

Fig. 241. Valve trim box Model B-2. Note: Mount strainer horizontally, not vertically as shown.

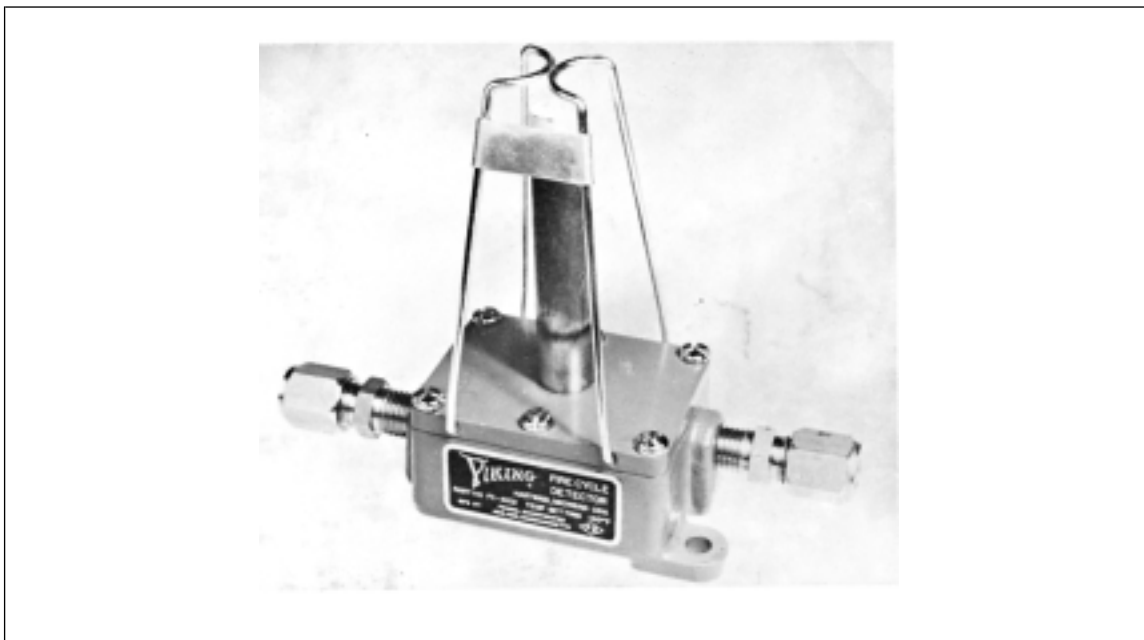

Fig. 242. Detector, Model A.

- a. The maximum spacing of detectors under the various types of roof and ceiling construction should be as specified in Tables 29, 30, and 31.
- b. Detector patterns should adequately cover monitors, skylights more than 50 sq ft (4.6 m²) and 4 ft (1.2 m) deep, most likely sources of fire, and the area around mechanical ventilators. It may be advantageous to stagger detector spacing across joists or beams. Lines of detectors should preferably be in the center of bays formed by framed-in girders. Avoid locations near local heat sources.

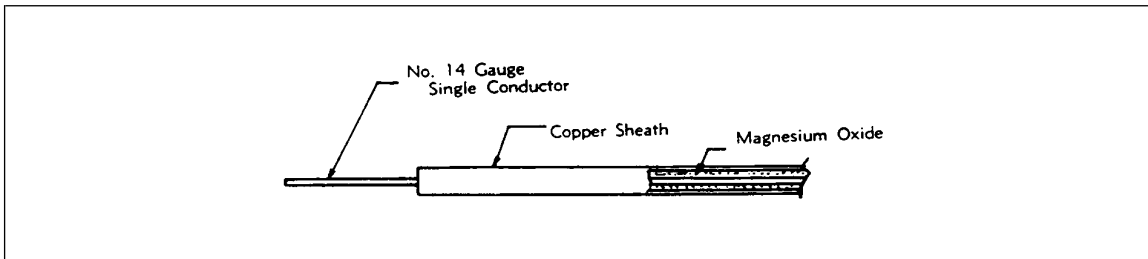

Fig. 243. Mineral-insulated (MI) cable.

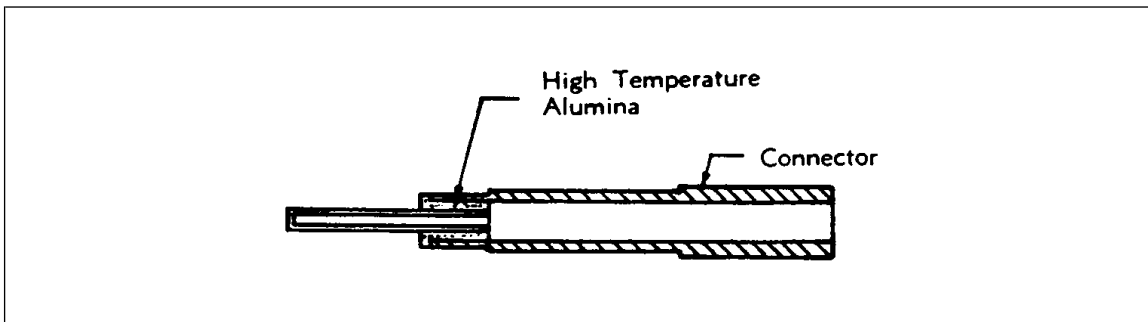

Fig. 244. MI connector.

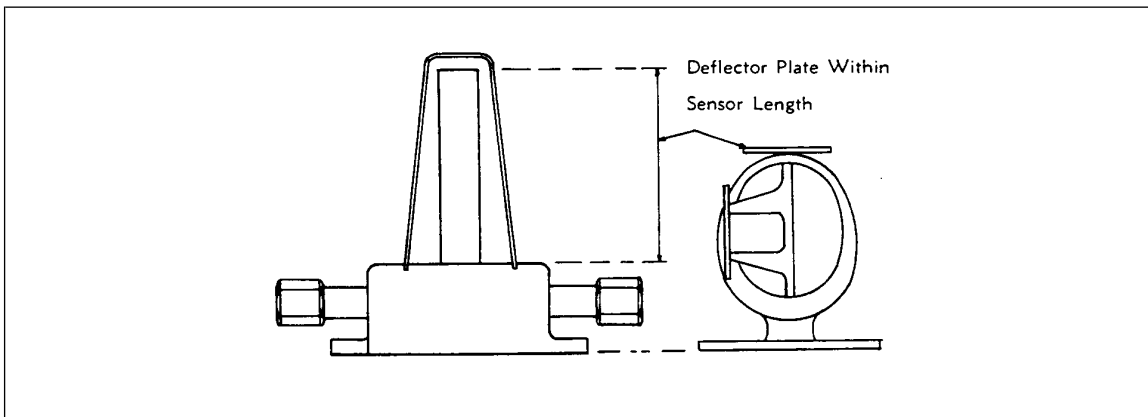

Fig. 245. Detector location.

- c. Place detectors under decks wider than 10 ft (3 m).
7. If concealment of the detector above the ceiling is desired in ordinary and extra hazard occupancies, detectors may be mounted as shown in Fig. 246.
 8. In light hazard areas, detectors may be mounted as shown in Fig. 247, providing that (a) the detector spacing is reduced 50%, and (b) the air pressure in the area above the ceiling is no greater than that in the room.

Strainers

The two strainers (2, in Fig. 236) should be installed with the screen removal plug facing down. Foreign material (scale, etc.) can plug either of these strainers. Plugging of the 1/2-in. (13-mm) strainer in the release line between the flow control and pilot solenoid valves will prevent the operation of the flow control valve. This strainer, therefore, “fails unsafe.” Plugging of the 1/4-in. (6.4 mm) strainer in the priming line (just upstream of the restriction orifice) will prevent the flow control valve from closing. It will remain open even after the pilot solenoid valves have closed on receiving a thermally actuated signal that the fire is out. This strainer therefore “fails safe.”

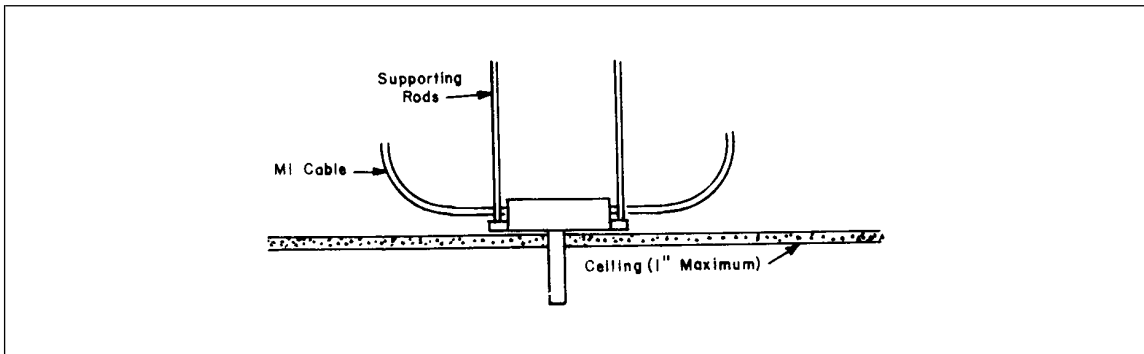

Fig. 246. Method of concealment of detector in ordinary- and extra-hazard occupancy areas.

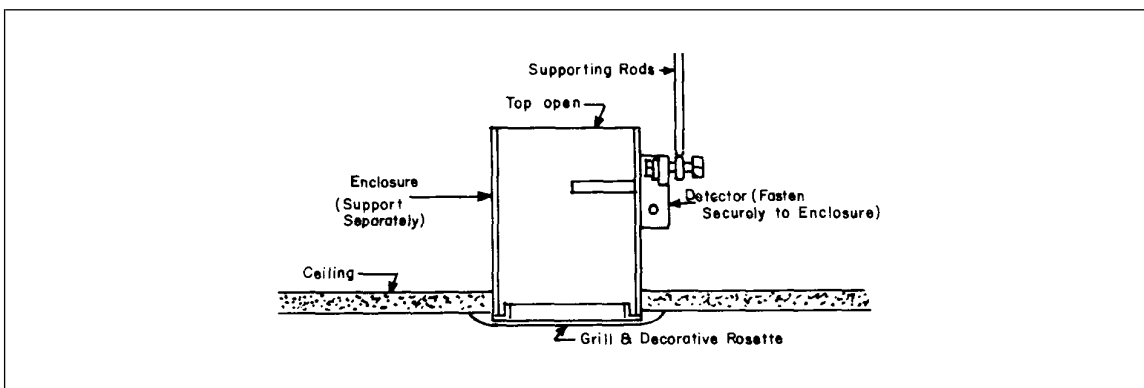

Fig. 247. Method of concealment of detector in light-hazard areas.

Priming Line Gauge

The priming line gauge should be an approved retard-type gauge.

Solenoid Valve Drain

The solenoid valve drains should be located where the flow from them may be observed.

MAINTENANCE, EMERGENCY CONDITIONS, AND POSSIBLE SOURCES OF TROUBLE

Firecycle Maintenance Procedure

IMPORTANT: The Firecycle selector switch (3, in Fig. 240) must be in the ON position for automatic Firecycle operation.

Table 29. Maximum Detector Spacing. Level Roof to 1 in. (25 mm) to 8 in. (203 mm) Roof Pitch.

Type of Ceiling Construction		Distance A ft (m)	Distance B ft (m)
Smooth, bar joist, open web. No beam depth over 4 in. (102 mm)		40 (12.2)	40 (12.2)
Joists, 0-3 ft (0-0.9 m) c to c. Joist depth more than 4 in. (102 mm)		36 (11)	32 (9.7)
	Beam Depth		
Beams, 3-5 ft (0.9-1.5 m) c to c.	4-14 in. (102-356 mm)	36 (11)	32 (9.7)
	14-18 in. (356-457 mm)	32 (9.7)	32 (9.7)
	18-22 in. (457-559 mm)	32 (9.7)	28 (8.5)
	22-24 in. (559-610 mm)	32 (9.7)	24 (7.3)
	Beam Depth		
Beams, more than 5 ft (1.5 m) c to c.	4-14 in. (102-356 mm)	36 (11)	36 (11)
	14-18 in. (356-457 mm)	36 (11)	32 (9.7)
	18-22 in. (457-559 mm)	36 (11)	28 (8.5)
	22-24 in. (559-610 mm)	36 (11)	24 (7.3)

Where only one row is required, the end detector is limited to 1/3 A

Table 30. Maximum Detector Spacing. Peak Roof Pitch Greater than 1 in. (25 mm) to 8 in. (203 mm).

Type of Ceiling Construction		Distance A ft(m)	Distance B ft(m)	
Smooth, bar joist, open web. No beam depth over 4 in. (102 mm)		40 (12.2)	40 (12.2)	
Beams perpendicular to peak	Joists 0 to 3 ft (0-0.9 m) c to c Joist depth more than 4 in. (102 mm)	36 (11)	32 (9.7)	
	Beams 3 to 5 ft (0.9-1.5 m) c to c	Beam Depth		
		4-14 in. (102-356 mm)	36 (11)	32 (9.7)
		14-18 in. (356-457 mm)	32 (9.7)	32 (9.7)
		18-22 in. (457-559 mm)	32 (9.7)	28 (8.5)
	22-24 in. (559-610 mm)	32 (9.7)	24 (7.3)	
	Beams more than 5 ft (1.5 m) c to c	Beam Depth		
		4-14 in. (102-356 mm)	36 (11)	36 (11)
		14-18 in. (356-457 mm)	36 (11)	32 (9.7)
		18-22 in. (457-559 mm)	36 (11)	28 (8.5)
22-24 in. (559-610 mm)	36 (11)	24 (7.3)		
Beams parallel to peak	Joist 0 to 3 ft (0-0.9 m) c to c Joist depth more than 4 in. (102 mm)	32 (9.7)	36 (11)	
	Beams 3 to 5 ft (0.9-1.5 m) c to c	Beam Depth		
		4-14 in. (102-356 mm)	32 (9.7)	36 (11)
		14-18 in. (356-457 mm)	32 (9.7)	32 (9.7)
		18-22 in. (457-559 mm)	28 (8.5)	32 (9.7)
	22-24 in. (559-610 mm)	24 (7.3)	32 (9.7)	
	Beams more than 5 ft (1.5 m) c to c	Beam Depth		
		4-14 in. (102-356 mm)	36 (11)	36 (11)
		14-18 in. (356-457 mm)	32 (9.7)	36 (11)
		18-22 in. (457-559 mm)	28 (8.5)	36 (11)
22-24 in. (559-610 mm)	24 (7.3)	36 (11)		

The Firecycle selector switch should be in the OFF position only when the thermal sensor circuit is impaired.

Periodic inspections should be made as a part of maintenance program, and should preferably be done by the system installer. The Firecycle system should be operated quarterly by heating a detector or by depressing the thermal test button (4, in Fig. 240).

Both priming line strainers (2, in Fig. 236) should be dismantled, inspected, and thoroughly cleaned (a) quarterly, (b) after every fire, and (c) after any prolonged flow through the solenoid valves. A new strainer screen should be installed if the existing screen is damaged during removal or cleaning. Spare ¼ and ½-in. (6.4 and 13 mm) strainers should be kept on hand (as with spare sprinkler heads) in the control cabinet.

Pilot solenoid valves V₁ and V₂; relays CR0, CR1, CR2 and CR3; and the timer should be replaced every ten years (Fig. 236).

Batteries should be maintained according to instructions posted in the control cabinet.

Both the control cabinet and the valve trim box should be kept locked and the keys entrusted to a responsible person.

If a malfunction of the Firecycle system occurs, check the following points before proceeding further:

1. Are fuses blown?
2. Has power supply been interrupted?
3. Is priming line to top of control valve (4, in Fig. 236) pressurized?
4. Are connectors between control valve trim box and Firecycle Panel intact?

Table 31. Maximum Detector Spacing. Shed Roof Pitch Greater than 1 in. (25 mm) to 8 in. (203 mm).

Type of Ceiling Construction		Distance A ft(m)	Distance B ft(m)	
Smooth, bar joist, open web. No beam depth over 4 in. (102 mm)		40 (12.2)	40 (12.2)	
Beams parallel to peak	Joists 0 to 3 ft (0-0.9 m) c to c Joist depth more than 4 in. (102 mm)	36 (11)	32 (9.7)	
	Beams 3 to 5 ft (0.9-1.5 m) c to c	Beam Depth		
		4-14 in. (102-356 mm)	36 (11)	32 (9.7)
		14-18 in. (356-457 mm)	32 (9.7)	32 (9.7)
		18-22 in. (457-559 mm)	32 (9.7)	28 (8.5)
	22-24 in. (559-610 mm)	32 (9.7)	24 (7.3)	
	Beams more than 5 ft (1.5 m) c to c	Beam Depth		
		4-14 in. (102-356 mm)	36 (11)	36 (11)
		14-18 in. (356-457 mm)	36 (11)	32 (9.7)
		18-22 in. (457-559 mm)	36 (11)	28 (8.5)
22-24 in. (559-610 mm)	36 (11)	24 (7.3)		
Beams perpendicular to peak	Joist 0 to 3 ft (0-0.9 m) c to c Joist depth more than 4 in. (102 mm)	32 (9.7)	36 (11)	
	Beams 3 to 5 ft (0.9-1.5 m) c to c	Beam Depth		
		4-14 in. (102-356 mm)	32 (9.7)	36 (11)
		14-18 in. (356-457 mm)	32 (9.7)	32 (9.7)
		18-22 in. (457-559 mm)	28 (8.5)	32 (9.7)
	22-24 in. (559-610 mm)	24 (7.3)	32 (9.7)	
	Beams more than 5 ft (1.5 m) c to c	Beam Depth		
		4-14 in. (102-356 mm)	36 (11)	36 (11)
		14-18 in. (356-457 mm)	32 (9.7)	36 (11)
		18-22 in. (457-559 mm)	28 (8.5)	36 (11)
22-24 in. (559-610 mm)	24 (7.3)	36 (11)		

Conditions and Possible Sources of Trouble (Fig. 248)

1. Flow control valve will not close.
 - a. Detector circuit open. Turn Firecycle selector switch to OFF position and check for continuity between terminals 4 and 5. Return switch to the ON position.

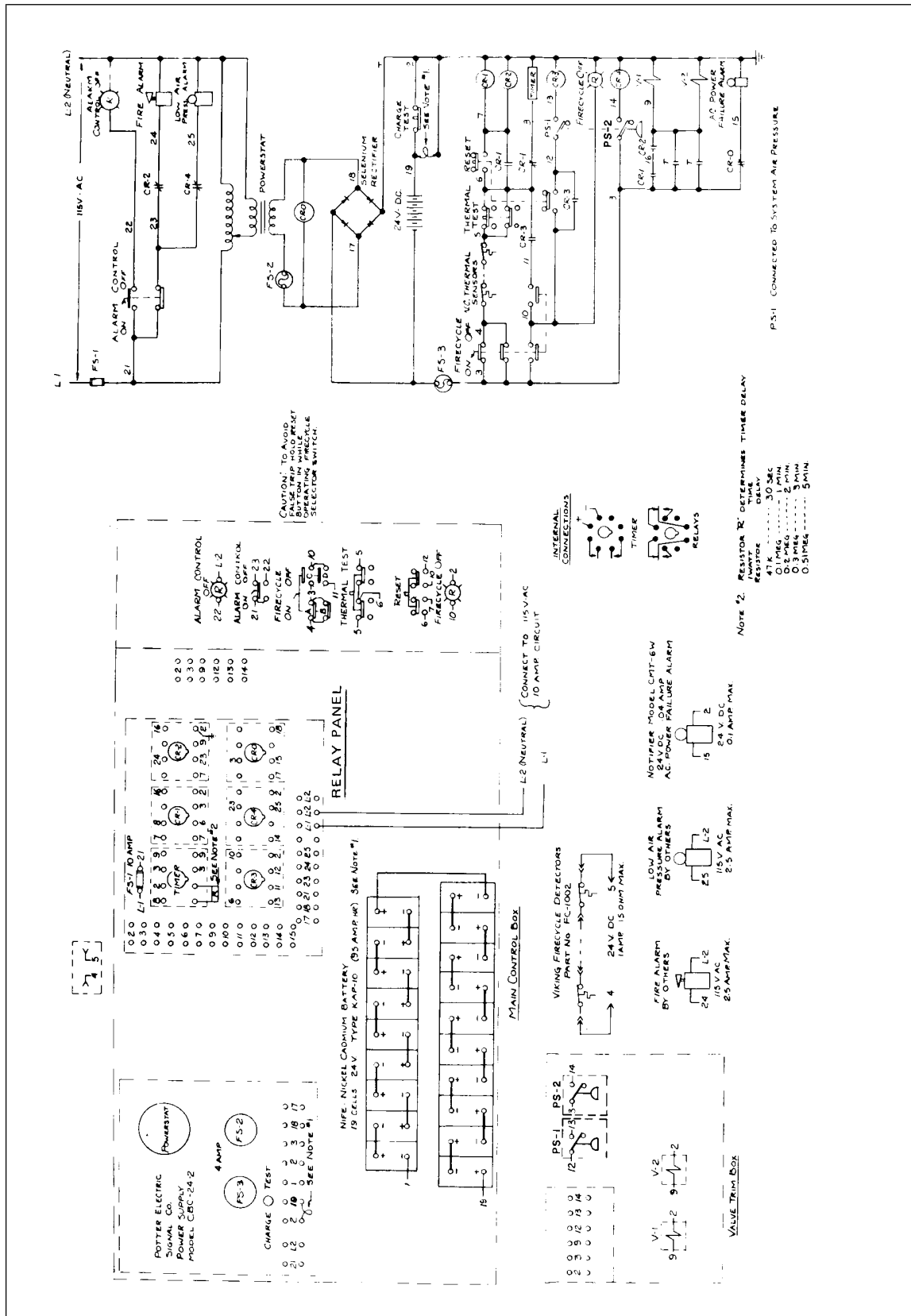

Fig. 248. Viking Firecycle wiring diagram.

- b. Thermal test button open. Remove FS-3 and check for continuity between Terminals 5 and 6. Replace FS-3.
 - c. Pilot solenoid valves V_1 and V_2 inoperative. Check for 24 to 28 volts to valve coils at coil leads.
 2. Fire alarm operates and flow control valve opens, but there is no fire.
 - a. Check fuse FS-3.
 - b. Follow steps of preceding Condition 1.
 3. Flow control valve opens on thermal test or detector signal, but does not close at end of timing cycle.
 - a. Follow steps of Condition 1.
 - b. Relay CR1 inoperative. Press and release thermal test button and check for 24 to 28 volts at timer between points 2 and 8.
 - c. Timer inoperative. Press and release thermal test button. Wait for time interval (see rating on timer) and check voltage. If 24 to 28 V dc is present between points 2 and 8, but not present between points 2 and 9, replace timer and repeat this step.
 4. Alternating current power failure alarm operates with 110 V ac present at terminals L1 and L2.
 - a. Check for 24 to 28 V ac at terminals 17 and 18 of power supply. If no voltage, check fuses FS-1 and FS-2. If fuses are good, attempt to get proper voltage by adjusting Powerstat. If still no voltage, replace Powerstat.
 - b. If 24 to 28 V ac present at terminals 17 and 18, check operation of relay CR0.
 5. Fire extinguished, but water does not shut off after normal delay. The Firecycle system is designed to continue waterflow after temperature drops to ensure fire is out. Length of delay will vary with individual systems (5 minutes delay typical).
 - a. **Make certain fire is extinguished.**
 - b. Make certain Firecycle selector switch (Fig. 240) is in ON position. If not, turn ON and press RESET button (Fig. 240).
 - c. Turn alarm control switch (2, Fig. 240) to OFF position.
 - d. Place fire watch and turn off manual water control valve.
 - e. Drain sprinkler system.
 - f. Replace all sprinklers that have operated.
 - g. Admit 10 psi (68.9 kPa) (0.69b) air to sprinkler system.
 - h. Turn Firecycle selector switch (3, Fig. 240) to OFF position and press RESET button (5, Fig. 240).
 - i. Admit water to top of flow control valve through priming line (4, in Fig. 236) until pressure equals sprinkler supply pressure.
 - j. Slowly open manual water control valve. The sprinkler system is now ready for LOSS IN SYSTEM PRESSURE operation. A loss in pressure in the sprinkler system will cause the flow control valve to open and admit water to the system.
 - k. Repair detector circuit and test for continuity between terminals 4 and 5.
 - l. While holding RESET button (5, Fig. 240) depressed, turn Firecycle selector switch (3, Fig. 240) to ON position.
 - m. Turn the alarm control switch (2, Fig. 240) to the ON position.
 6. No fire, but damaged detector circuit opens flow control valve.
 - a. Turn alarm control switch (2, Fig. 240) to OFF position. Alarm control light (1, Fig. 240) should now be on.
 - b. Close manual water control valve.

- c. Drain water from the system and pressurize with air at 10 psi (69 kPa) (0.69b).
 - d. Turn Firecycle selector switch (3, Fig. 240) to OFF position and press RESET button (5, Fig. 240).
 - e. Admit water to top of flow control valve through priming line (4, Fig. 236) until pressure equals sprinkler supply pressure.
 - f. Slowly open manual water control valve. The sprinkler system is now set for LOSS IN SYSTEM PRESSURE operation. A loss of pressure in the sprinkler system (when a sprinkler opens) will cause the flow control valve to open and admit water to the system.
 - g. Repair detector circuit and test for continuity between terminals 4 and 5 (Fig. 248).
 - h. While holding RESET button (5, Fig. 240) depressed, turn Firecycle selector switch (3, Fig. 240) to ON position. The fire alarm will operate if the Firecycle circuit is functioning properly. This indicates that the thermal sensor circuit has been repaired, but the alarm control switch (2, Fig. 240) is in the OFF position. Turn the alarm switch to the ON position to turn off alarm. Alarm control light (1, Fig. 240) should now be off.
7. No fire, but sprinkler system is damaged, causing loss of air pressure; low pressure alarm operates. Detectors have not detected the presence of heat; therefore, the flow control valve remains shut but will open if there is a fire. **Do not Shut off manual water control valve.**
- a. Turn low pressure alarm off by closing alarm control switch (2, Fig. 240) to OFF and repair damaged system.
 - b. Establish correct air pressure in system (10 psi (69 kPa) (0.69b)) and turn alarm control switch to ON.

TESTING Detectors

A maintenance schedule should be established to functionally test all detectors once every 5 years, and 20% of them in each 12-month period.

The operation of detectors may be checked without opening the flow control valve as follows:

1. Hold RESET button (5, Fig. 240) depressed and turn Firecycle selector switch (3, Fig. 240) to OFF position.
2. Connect ohmmeter to terminals 4 and 5 in control cabinet (Fig. 248).
3. Apply heat to detector. When detector operates, ohmmeter will indicate an open circuit. An ordinary gun-type hair dryer may be used as a heat source for this test.
4. Remove heat from detector. Allow ample time for detector to return to, or near, ambient temperature.
5. Repeat Steps 3 and 4 for each detector tested.
6. After final test, remove ohmmeter and return Firecycle selector switch (3, Fig. 240) to ON position.

WARNING: IF FIRECYCLE SELECTOR SWITCH IS NOT RETURNED TO ON POSITION, THE FIRECYCLE CONTROL IS OFF, AND THE SPRINKLER SYSTEM IS SET FOR LOSS IN SYSTEM PRESSURE OPERATION ONLY.

System

Record results of tests on the form furnished with the valve.

1. Observe and record water supply pressure.
2. Open flow test and drain valve (3, in Fig. 236) fully. Record water supply pressure again. Shut valve.
3. Compare these readings with those previously taken.
4. Check air pressure in sprinkler system (10 psi (68.9 kPa) (0.69b)).
5. While holding RESET button (5, Fig. 240) depressed, turn Firecycle selector switch (3, Fig. 240) to OFF position. The System is now set for LOSS IN SYSTEM PRESSURE OPERATION.

(Note: Read steps 7 and 8 before proceeding with step 6).

6. Check the "loss in pressure" operation of system and low air pressure alarm by opening the test pipe on sprinkler system.
7. Observe and record air pressure at the moment low air pressure alarm operates (8 psi (55 kPa) (0.55b typical)).
8. Observe and record air pressure at the moment solenoid valves V_1 and V_2 (18, in Fig. 236) open 7 psi (48 kPa) (0.48b) typical). At this point, the flow control valve should open and the water motor alarm operate. The priming line gauge should quickly indicate a pressure drop. Observe and record the water pressure on the priming line gauge at the time the flow control valve opens. An upward trend indicates a potentially dangerous plug in the water release system.
9. Measure and record length of rod visible in flow control valve's position indicator (13, Fig. 236). A minimum of 1 in. (25.4 mm) indicates valve is fully open.
10. While observing position indicator rod, hold RESET button (5, Fig. 240) depressed and turn Firecycle selector switch to ON position. Record the lapse between the times at which selector switch is turned on and the position indicator retracts and stops moving, approximately 1 in. (25 mm). If supply pressure is approximately the same as recorded in previous tests, this time period should also be within 10 seconds of previous readings (30 to 60 sec typical for various supply pressures).
11. If closing of flow control valve appears to be too slow, clean priming line strainer (2, Fig. 2) and orifice (1, Fig. 2). Repeat step 10, recording new closing time.

Measure a-c voltage at terminals L1 and L2 (Fig. 248) on power supply in main control cabinet (110-120 volts).

13. Measure and record d-c voltage at terminals 2 and 3 (Fig. 248) on relay panel in main control panel (26 to 29 volts).
14. Observe level of battery electrolyte. It must not be below top of plates. Distilled water may be added as required.
15. Check condition of battery and a-c power failure alarm by disconnecting a-c power. Then, at end of one hour, measure and record d-c voltage at terminals 2 and 3 on relay panel in the control cabinet and compare with reading taken in step 13. Voltage change should be less than 1 volt.

WARNING: BE SURE TO RECONNECT A-C POWER AND A-C POWER FAILURE ALARM AFTER COMPLETING THIS TEST.

The following tests may be done during the hour.

16. Check operation of both solenoid valves (18, Fig. 236) in trim box while the Firecycle selector switch (3, Fig. 6) is in ON position. Press thermal test button (4, Fig. 240) and observe water flowing into drain from each solenoid valve. This causes the flow control valve to open, and the fire alarm to operate.
17. Check closing of solenoid valves (18, Fig. 236) by pressing RESET button. Water flowing into drain should stop, indicating solenoid valves have closed. Pressure will build up in the top chamber of the flow control valve which should close.
18. Check timer operation by pressing and holding thermal test button (4, Fig. 240) until the flow control valve fully opens. Observe and record time required for flow control valve to close after thermal test button is released. DO NOT PRESS RESET BUTTON. The time required for valve to close during this test minus the time recorded in step 10 indicates length of timer operation.
19. Drain water completely from system and close test outlet opened in step 6.
20. Observe air buildup in system and again check operation of low pressure alarm. It should not operate after pressure reaches approximately 7 psi (48 kPa) (0.48b). Air should build up to remain at a fixed pressure 10 psi (68.9 kPa) (0.69b).
21. Turn Firecycle selector switch (3, Fig. 240) to OFF position while holding RESET (5, Fig. 240) button depressed.
22. Disconnect both ends of the detector circuit at junction mounted on the main control cabinet.
23. Connect one lead of a 500- or 1000-volt megger to the sheath and the other lead to the pin (inner conductor). Reading should exceed 10 ohms.

24. Record readings and compare with those previously taken. Reconnect cable to the junction box.
25. Check resistance between terminal 2 (Fig. 248) on relay panel and ground with ohmmeter (should read zero).
26. Check operation and condition of Firecycle detectors per instructions.
27. Turn Firecycle selector switch to ON position while holding RESET button depressed.
28. With 115 V ac present at terminals L1 and L2 (Fig. 248) of battery charger, and a-c failure alarm properly connected, the system is now restored to automatic Firecycle operation and the testing is complete.
29. The battery charging rate may be checked by replacing the jumper between charger terminals 2 and 19 with a suitable ammeter. The trickle charge should be 0.09 to 0.10 amp when the battery is fully charged (27.0 volts at the battery terminals). Press the charge test button (Fig. 248) and read the meter. Replace jumper after reading meter.

NOTE: The NFPA has no standard covering the Viking Firecycle System.

4.15 Viking Model D, D2, D3, D4

Deluge Systems and Preaction Sprinkler Systems With Viking Automatic Water Control Valves

MODEL D, 2-INCH 1936-1962, 3-, 4- AND 6-INCH 1935-1962; MODEL D2, 2-, 3-, 4-, AND 6-INCH 1962-1966 MODEL D3, 2-INCH, 1966; MODEL D4, 2-, 3-, 4-, AND 6-INCH 1966-TO DATE

The Viking (Tyden) Model D automatic water-control valve (Fig. 249) is a differential type valve of angle design. The clapper is held on its seat by water pressure in a chamber (C, in Fig. 249) above the clapper. The pressure chamber is formed by the top, clapper, and rubber diaphragm. When pressure is released the clapper rises vertically, guided by the rubber diaphragm which is attached to the clapper and valve body.

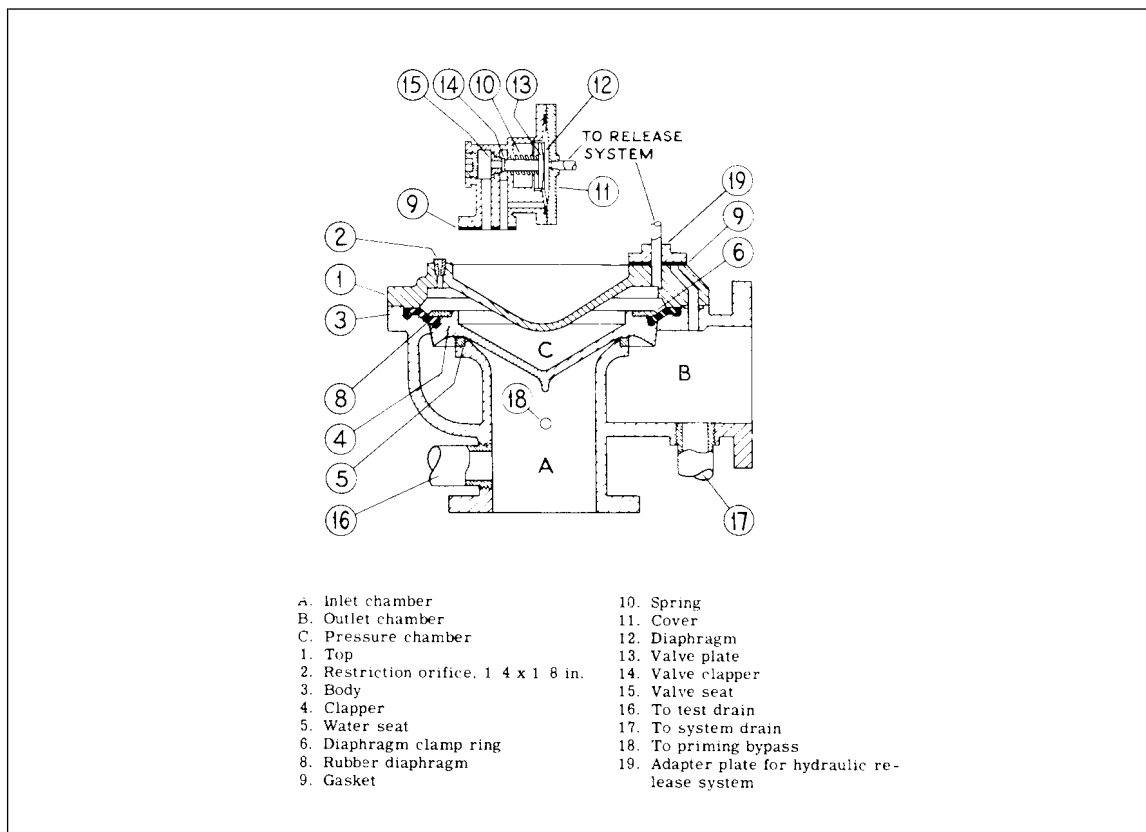

Fig. 249. Viking 6-in. Model D Automatic Water-control Valve with valve adapter plate for hydraulic release systems. Diaphragm bypass valve for pneumatic release systems shown above.

The Model D2 valve (Fig. 250) is the same as the Model D valve except for the method of attaching the diaphragm bypass valve. The Model D2 has a tapped connection while the Model D has a four-hole flange connection. The Model D3 (Fig. 250) has standard female pipe threads on inlet and outlet. The Model D4 (Fig. 2) has a rubber-to-metal seat, and a tapped hole is provided in the center of the cover for the release and priming line connections.

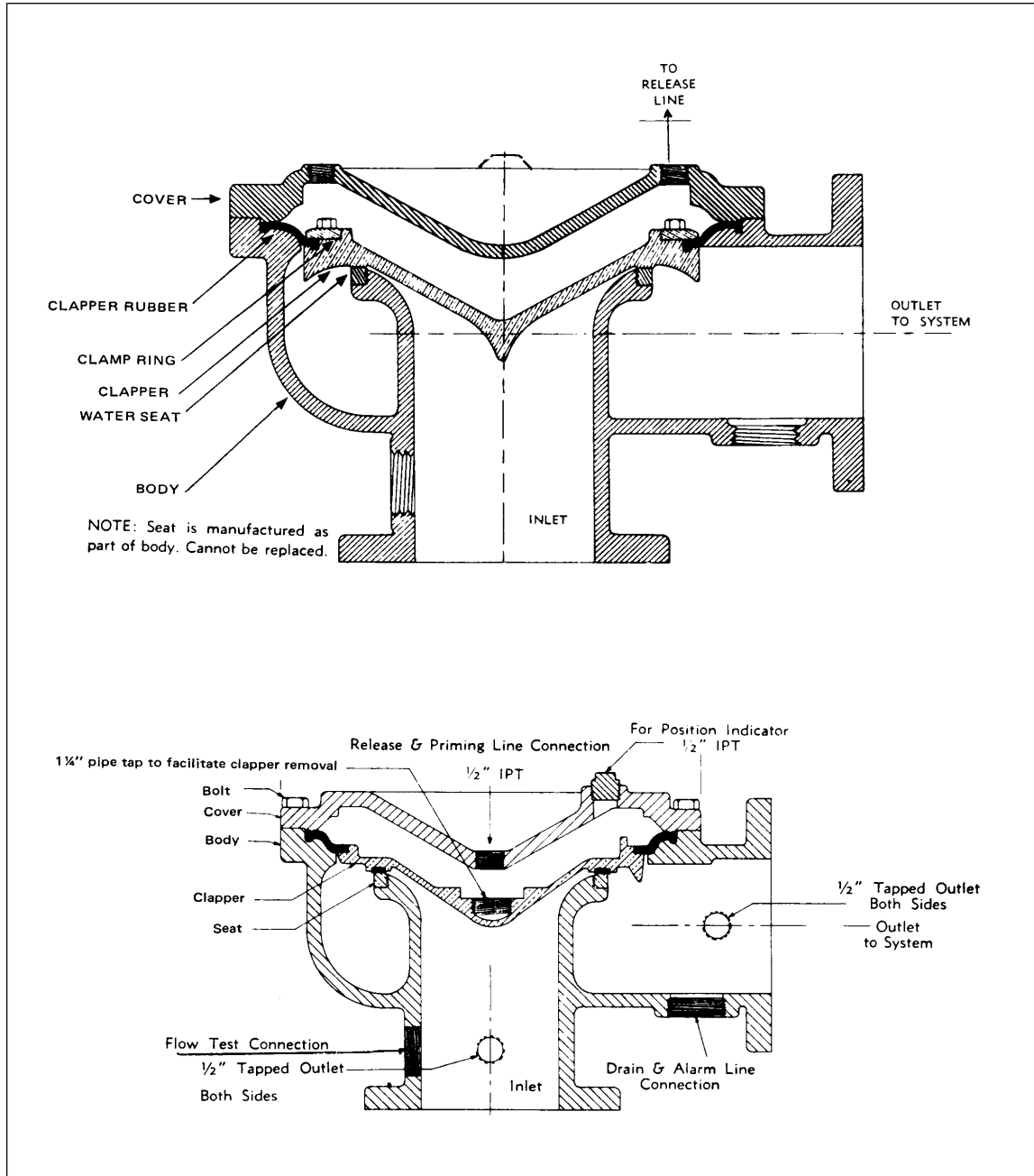

Fig. 250. (Upper) Viking deluge valve Model D2 and D3. (Lower) Viking deluge valve Model D4.

RELEASE SYSTEMS

Any one of the following five release systems may be used to trip the automatic water-control valve:

1. Hydraulic or a pilot line system (Fig. 251) using Type A thermostatic releases (4, in Fig. 251) and Type A remote manual control (5, in Fig. 251) which are connected directly to the pressure chamber (C, in Fig. 251) through 1/2-in. galvanized pipe. In addition, automatic sprinklers (minus deflectors) (8, in Fig. 251) and emergency manual trip valves (6, in Fig. 251) may be installed in the 1/2-inch pipe to release pressure. Details of Type A thermostatic releases are given in Fig. 252 and 253.

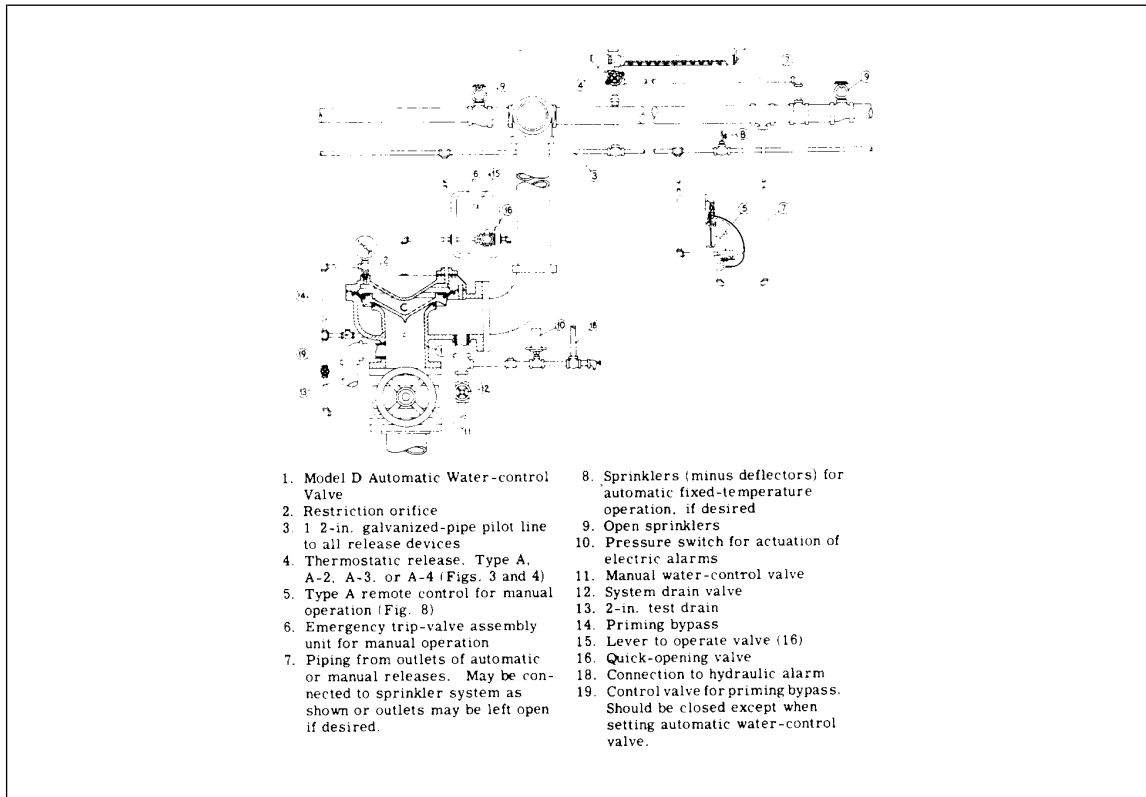

Fig. 251. Deluge system hydraulically operated with Type A thermostatic releases. Type A remote control, automatic sprinklers (minus deflectors), and emergency trip-valve release.

2. Pneumatic system using Type A thermostatic releases and Type A remote manual control which are connected through 1/2-in. galvanized pipe to a diaphragm bypass valve (Fig. 249 and 254 connected to the pressure chamber (C, in Fig. 249).

3. Pneumatic system (Fig. 255 and 256) using Type B thermostatic releases and Type B remote manual control which are connected through 1/4-in.-OD copper tubing through a diaphragm bypass valve (Fig. 249 and 254) connected to the pressure chamber (C, in Fig. 249). Details of the Type B thermostatic releases are given in Fig. 257.

4. Hydraulic or pilot line system (Fig. 258) using Model C1 releases (Fig. 259) connected to the diaphragm chamber of the water control valve through a Model C1 pressure operated release valve (PORV) (Fig. 260). The Model C1 release allows for either rate-of-rise or fixed-temperature operation. *Note: the PORV may be omitted when a manual reset releasing device is used.*

5. Pneumatic preaction (Fig. 261) or deluge (Fig. 262) system using Model C1 releases connected to the diaphragm chamber of the water control valve through a Model C1 PORV and a Model B, D2, or D3 diaphragm bypass valve (Fig. 254).

6. Electrical preaction or deluge systems using rate-of-rise or fixed temperature releases are not approved by Factory Mutual.

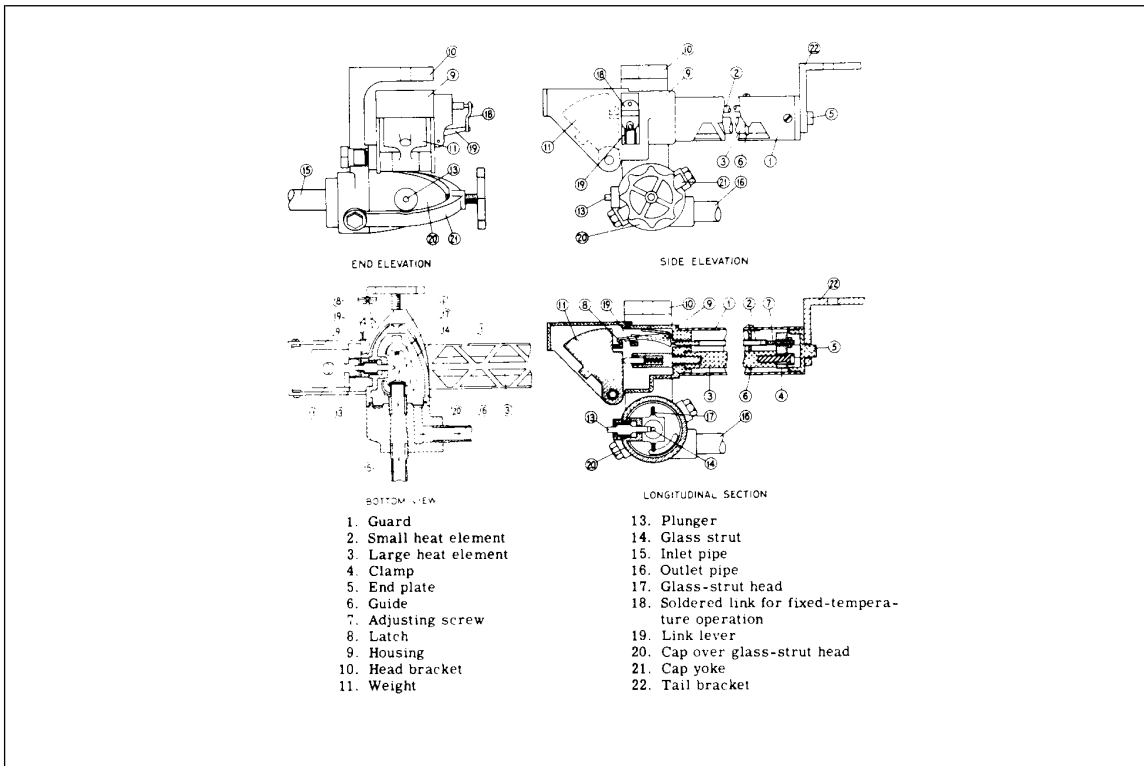

Fig. 252. Type A-4 thermostatic release.

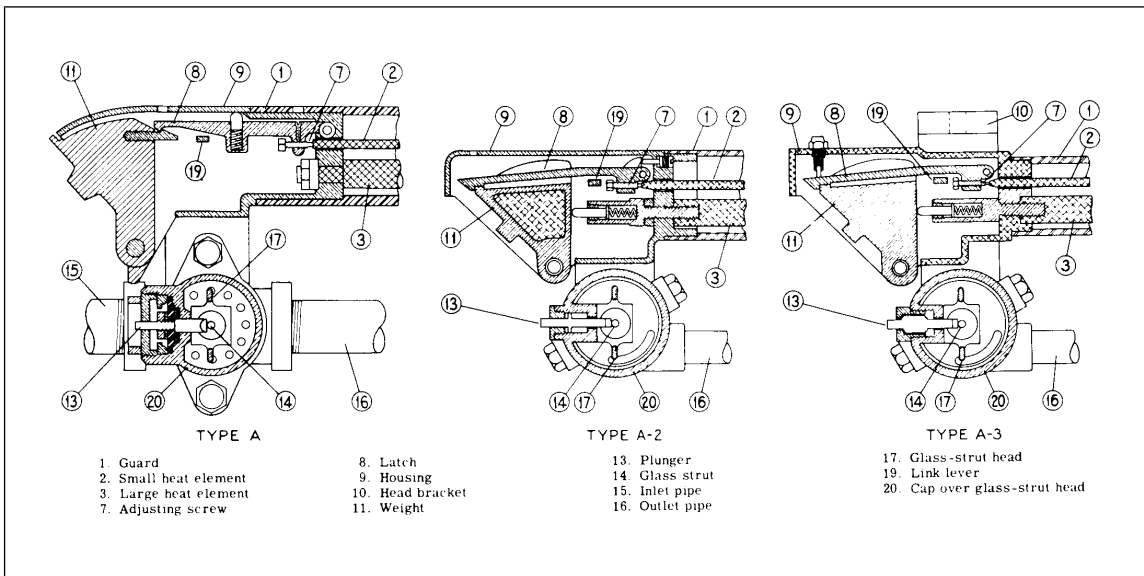

Fig. 253. Types A, A-2, and A-3 thermostatic releases. Operating principle and other details same as Type A-4 thermostatic release. See Fig. 254.

With the hydraulic release system, water-columning of the water-control valve can occur if the Type A thermostatic releases are installed at too high an elevation. For the 6-in. water-control valve, the manufacturer recommends that the height in feet of the highest release above the valve should not be greater numerically than the water pressure in psi at the valve; i.e., 60 ft maximum elevation difference for 60 psi. For 2-, 3-, and 4-in. water-control valves, the elevation should not exceed one-half the pressure; i.e., 30 ft for 60 psi. If necessary to exceed these elevations, an antiwater-columning device (Fig. 263) is used.

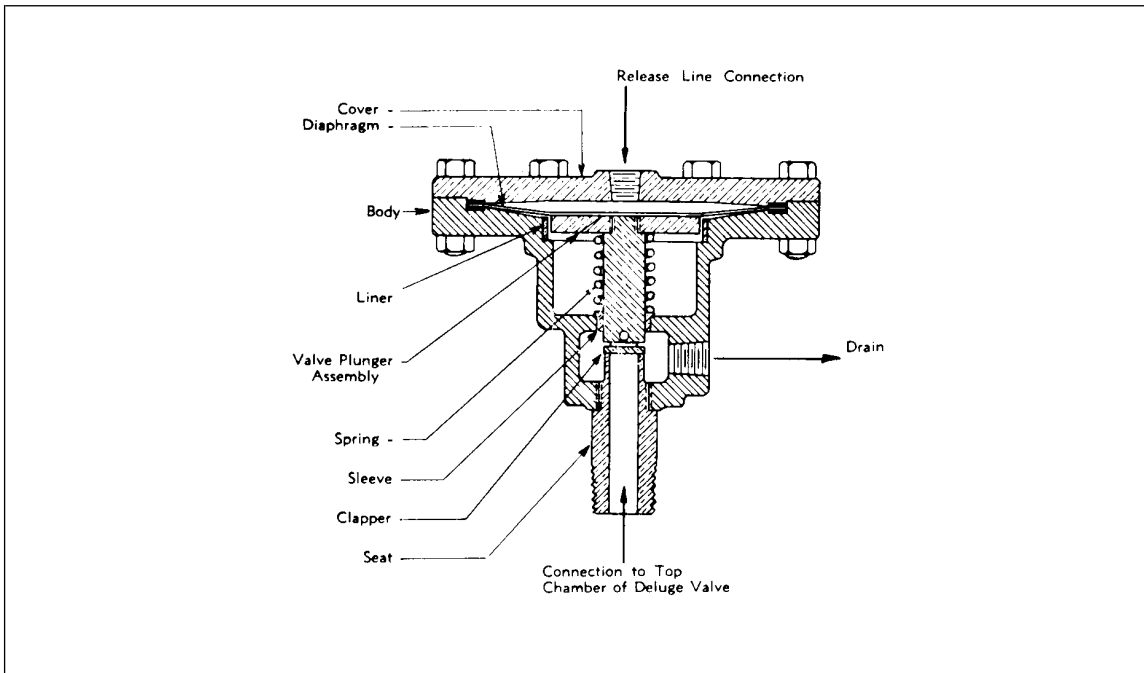

Fig. 254. Model D2 diaphragm bypass valve.

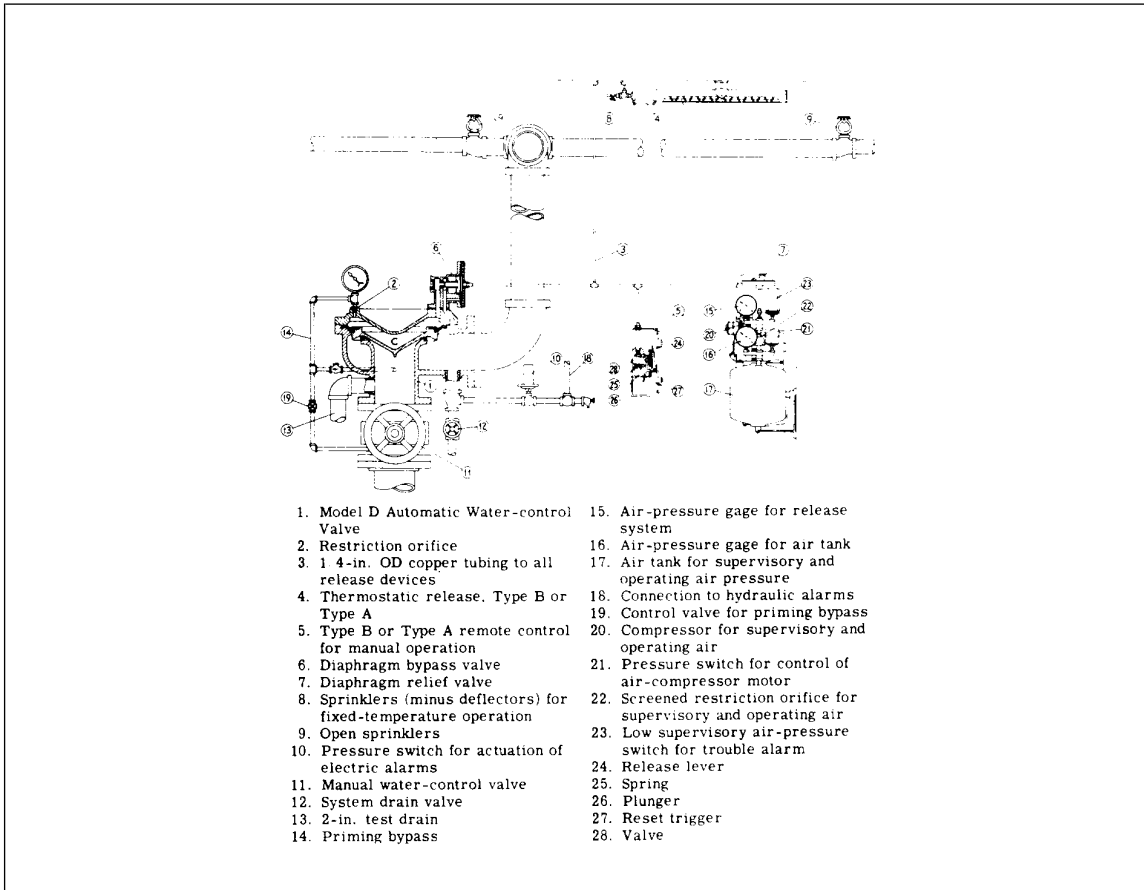

Fig. 255. Deluge system - pneumatically operated with Type B thermostatic release and Type B remote manual control.

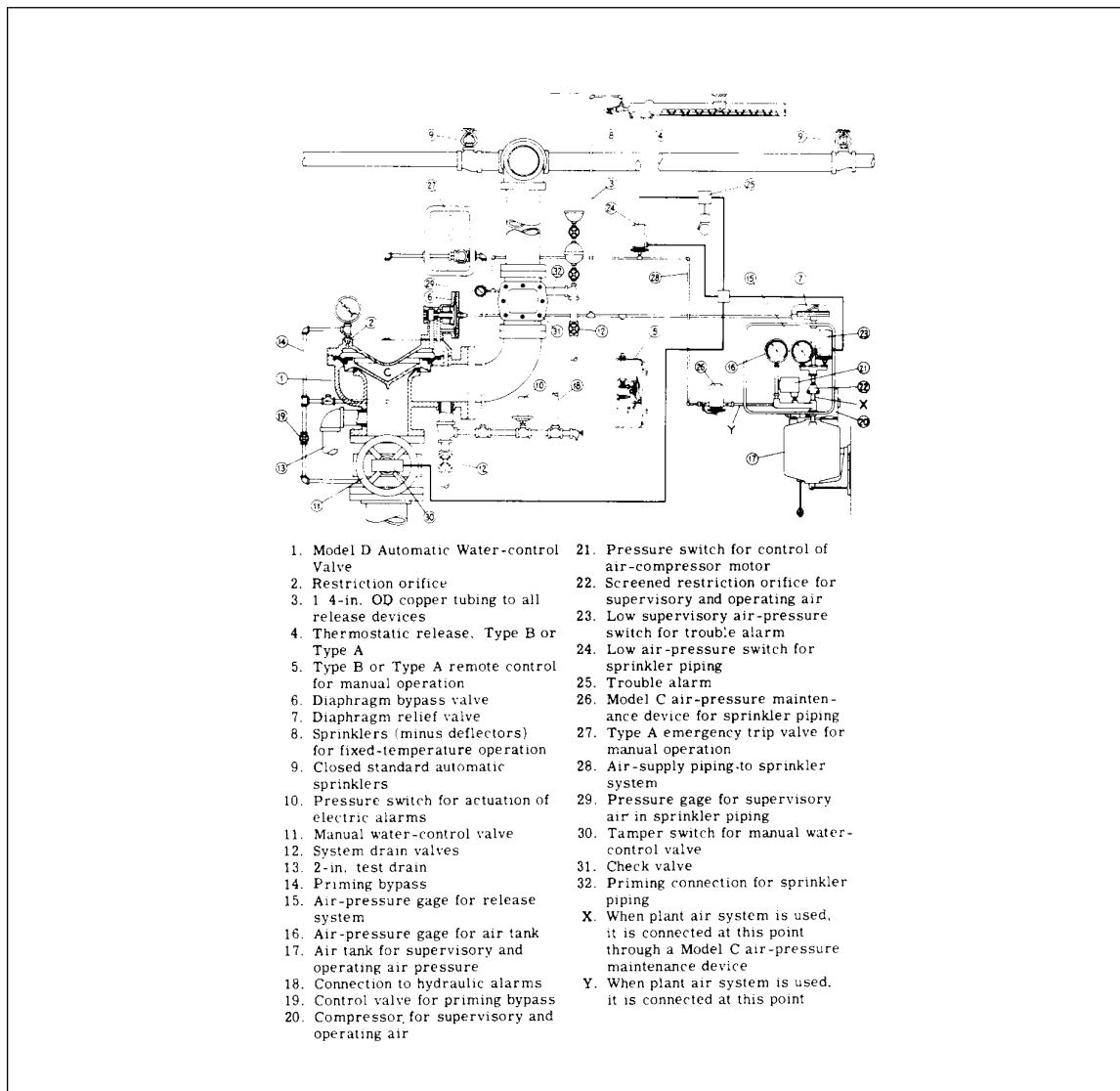

Fig. 256. Preaction sprinkler system - pneumatically operated with Type B thermostatic release and Type B remote control.

FIRE DETECTION AND ACTUATING DEVICES

The Viking automatic fire detection devices operate on both rate-of-rise and fixed temperature. Rate-of-rise operation is based on difference in heat absorption rates between two aluminum rods of different diameter. Fixed temperature operation is by a fusible link.

In the Type A thermostatic release (Fig. 252 and 253), the small (2, in Fig. 252 and 253) and large (3, in Fig. 252 and 253) aluminum heat element are clamped together at one end.

The opposite end of the large element is rigidly connected to the housing wall (9, in Fig. 252 and 253). The corresponding end of the small element is free to move in an opening in the housing. With normal slow temperature changes, both elements expand at the same rate and the release does not operate. If the rate of rise exceeds a predetermined figure, the small element expands faster and causes a latch (8, in Fig. 252 and 253) to pivot, releasing a weight (11, in Fig. 252 and 253). The weight strikes a plunger (13, in Fig. 252 and 253) which in turn breaks the strut (14, in Fig. 252 and 253) of a glass-strut head (17, in Fig. 252 and 253) releasing the water or air in the release piping. The glass-strut head has a nonstandard 1/2-in. pipe thread to prevent its use in a sprinkler system.

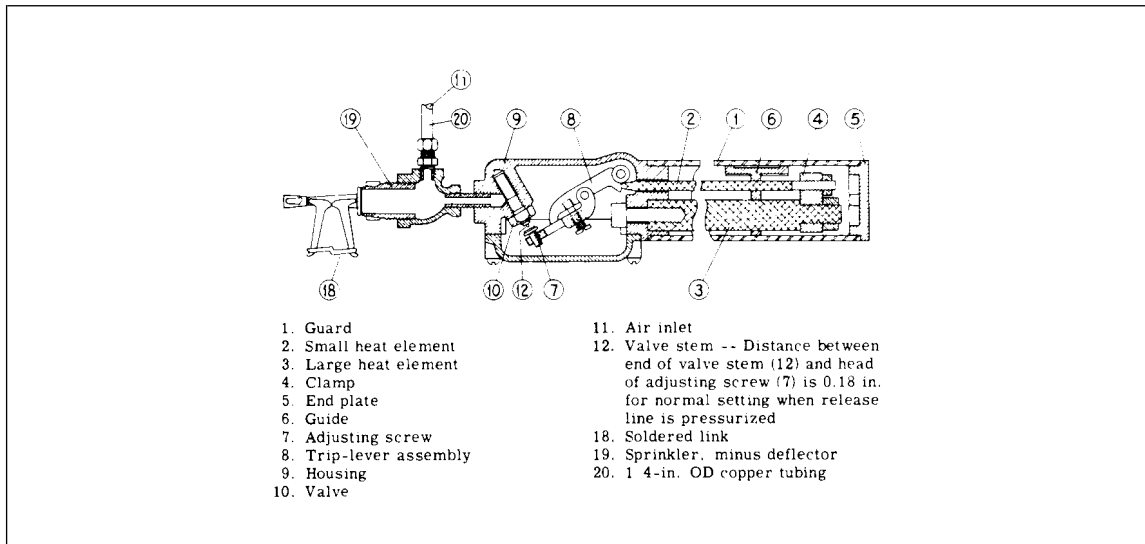

Fig. 257. Type B thermostatic release.

Fixed-temperature operation with the Type A thermostatic release occurs when heat melts a solder link (18, in Fig. 252 and 253), freeing a lever (19, in Fig. 252 and 253), which pivots and raises a latch (8, in Fig. 252 and 253). This releases the weight and breaks the glass strut as described above.

In the Type B thermostatic release (Fig. 257), rate-of-rise operation is similar to that of the Type A except that expansion of the small heat element causes a trip-lever assembly (8, in Fig. 257) to pivot and depress a valve, releasing the air pressure in the system. Fixed temperature operation with the Type B thermostatic release is through a sprinkler head minus deflector (19, in Fig. 257), installed in a tee at the air inlet (11, in Fig. 257) of the release.

In the Type C1 thermostatic release (Fig. 259), rate-of-rise operation is achieved when the tube element (2, in Fig. 259) expands more rapidly than the rod element (3, in Fig. 259) due to its preferred location. This expansion pulls the rod element causing the arm (8, in Fig. 259) to rotate on its pivot pin (6, in Fig. 259). The set screw (7, in Fig. 259) moves downward to open the Schrader valve (10, in Fig. 259). Air or water escapes to atmosphere at a rate greater than that at which it can enter through the orifice. Reduction of pressure above the diaphragm (12, in Fig. 259) then permits the clapper (14, Fig. 259) to open. Air or water then flows to atmosphere causing the water control valve to operate.

The rate-of-rise mechanism on the Type C1 thermostatic release (Fig. 259) cannot be adjusted. Set screw 7 (Fig. 259) can be adjusted as shown in Fig. 24 and explained under annual maintenance. The manufacturer may, in special instances, recommend an extra $\frac{1}{4}$ turn of the set screw (change of 0.010 in. from normal setting) to compensate for small heat surges. Any deviation should only be done by the manufacturer.

Fixed-temperature operation of the Model C1 release is achieved by installing an automatic sprinkler where shown on Fig. 259.

The Type A remote manual control (Fig. 264) is used in hydraulic or pneumatic release systems to permit manual tripping of the automatic water-control valve from any convenient location. Depressing the push-button (2, in Fig. 264) causes a latch (8, in Fig. 264) to pivot and release the weight (11, in Fig. 264), breaking the glass-strut (14, in Fig. 264) as described for the Type A thermostatic release earlier.

The Type B remote manual control (Fig. 255) is used in pneumatic release systems for manual tripping of the water-control valve from various locations. Pulling the release lever (24, in Fig. 255), permits the reset trigger (27, in Fig. 255) to pivot and depress the valve (28, in Fig. 255), releasing the pressure in the system.

The emergency trip valve assembly (6, in Fig. 251) is installed in hydraulic systems near the water-control valve for manual tripping. Pulling the lever (15, in Fig. 251) causes the valve (16, in Fig. 251) to open and relieve the pressure.

SUPERVISORY AIR FOR PNEUMATIC RELEASE SYSTEMS

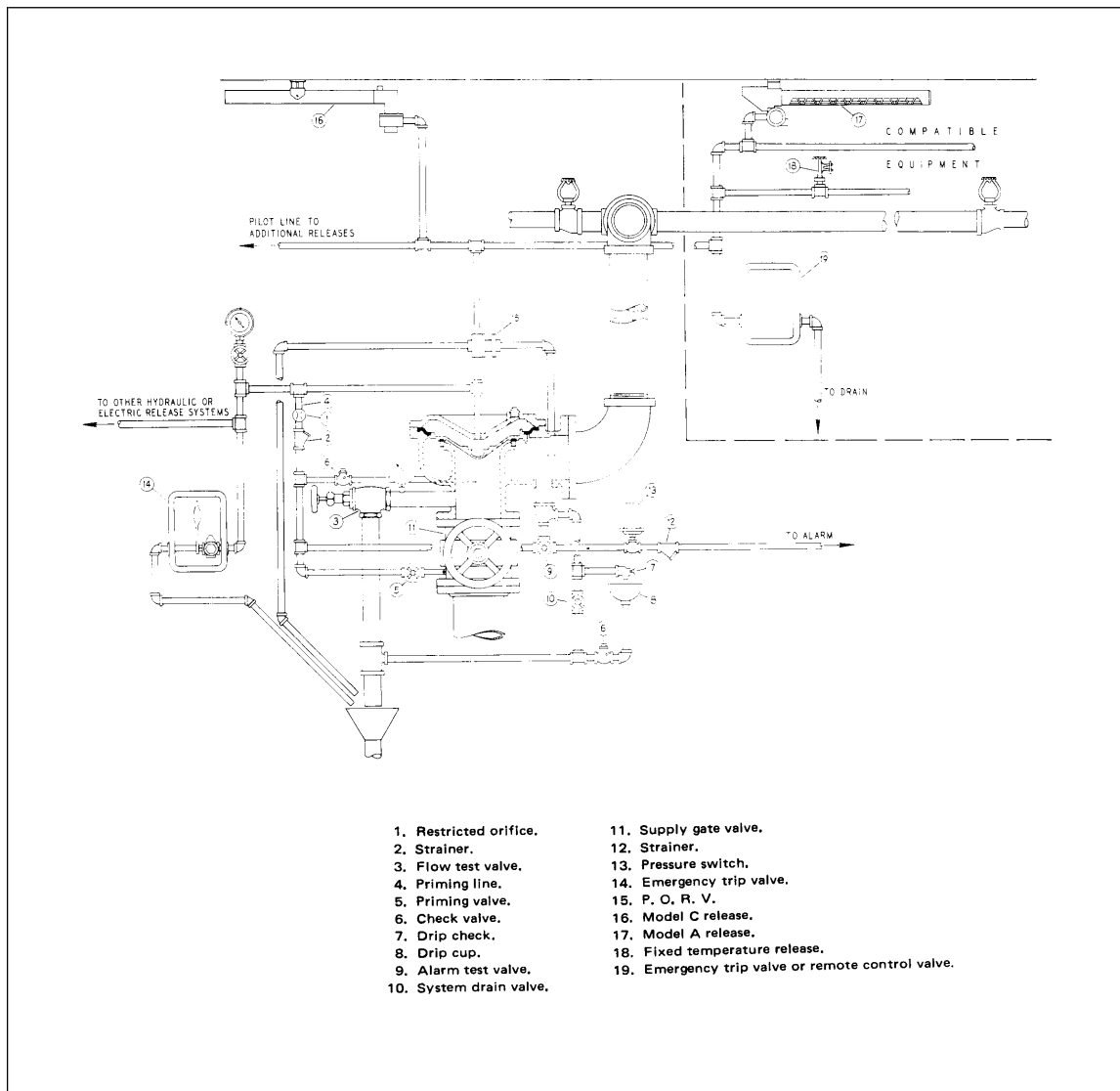

Fig. 258. Deluge system, hydraulically operated, with Model C thermostatic release and pressure-operated relief valve.

Air for a pneumatic release system of a deluge sprinkler system or for the release system and sprinkler piping of a preaction sprinkler system is supplied by an air compressor unit or from a reliable plant air system. Failure of the air supply will cause the water control valve to trip if there are any leaks in the release system.

The air compressor unit (Fig. 255) includes an air tank (17, in Fig. 255), compressor (20, in Fig. 255), and related gages (15 and 16, in Fig. 255). The compressor is normally arranged to cut in at 20 psi and shut off at 40 psi, normalizing at about 30 psi, which is the operating pressure in the release system and air tank. If a leak occurs in the release system, air is supplied through a screened restriction orifice (22, in Fig. 255).

The Model C air pressure maintenance device (Fig. 265) is used with plant air systems. A drop in air pressure in the release system permits the diaphragm to move and the valves (6, in Fig. 265) to open and admit air. A check valve (7, in Fig. 265) prevents leakage through the device if the air supply fails.

AUXILIARY EQUIPMENT

The Model B diaphragm bypass valve (Fig. 249) is used only with pneumatic release systems to reduce pressure in the chamber (C, in Fig. 249) of the water control valve. Normally pressure in the chamber is confined between the diaphragm (12, in Fig. 249) and cover (11, in Fig. 249) and keeps the clapper on its

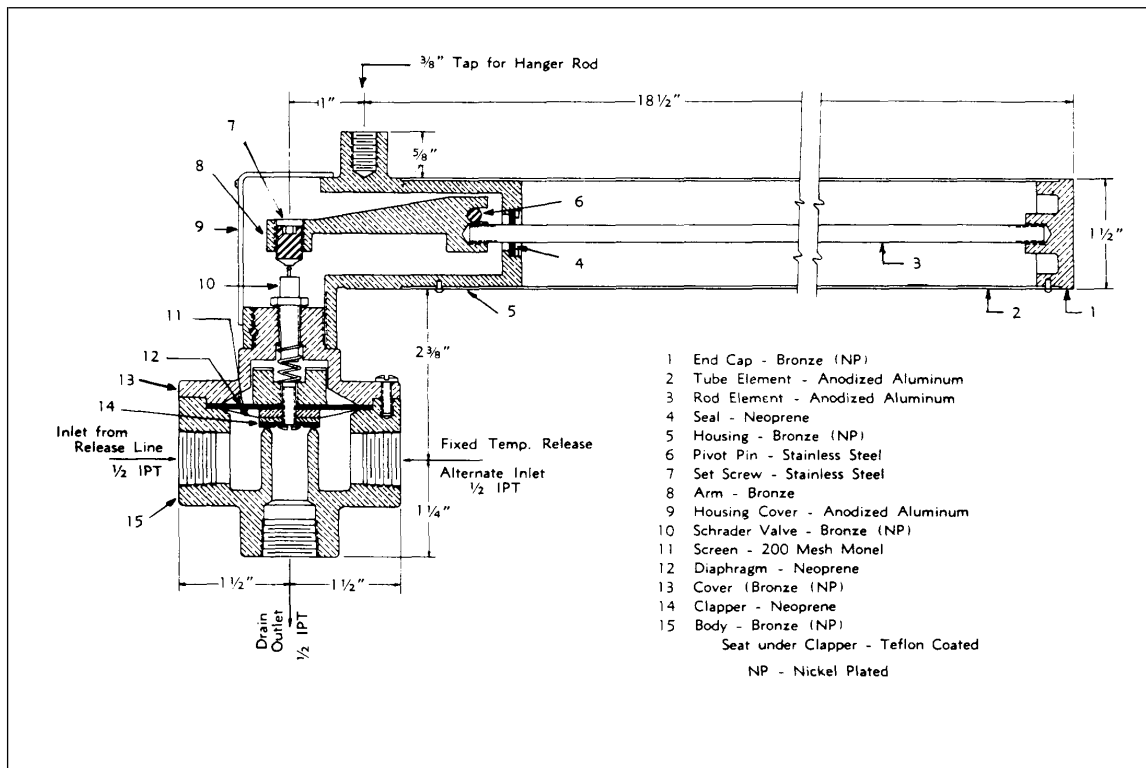

Fig. 259. Model C1 thermostatic release.

seat. When the pressure is reduced, the clapper lifts and permits water to bleed off from the chamber faster than it can be supplied through the restriction orifice (2, in Fig. 249).

The Model D2 diaphragm bypass valve (Fig. 254) is the same as the Model B except for mounting. The Model B has a flange connection and is mounted horizontally on the Model D water-control valve. Model D2 screws directly into the cover of the Model D2 water-control valve. The two bypass valve models are interchangeable on the two water control valve models by use of adapter flanges. (See Fig. 266). The Model D3 diaphragm bypass valve is an improved version of the Model D2 in that it has a rubber clapper to ensure positive seating. The body is made of bronze instead of cast iron to improve corrosion resistance.

Note: Make sure that the drain line from the diaphragm bypass valve is not solidly connected to drain. There should be an open cup in the drain line.

The diaphragm relief valve (Fig. 267) is used with pneumatic Type B release systems to prevent excessive air pressure in the diaphragm bypass valve and air tubing. This might occur if thermostatic releases cooled during a fire and allowed the valve (10, in Fig. 257) to close. Normally, the pressure below the diaphragm (14, in Fig. 267) keeps the valve operating arm raised. When pressure in the release system drops, the diaphragm moves and depresses the valve (7, in Fig. 267), releasing air to atmosphere and preventing air buildup if all other valves close. In resetting, the manual reset lever (11, in Fig. 267) is lifted to allow pressure to build up in the release system, raising the diaphragm and valve operating arm.

The release line accelerator (Fig. 268) may be used on a pneumatic release system in place of a diaphragm relief valve on any deluge valve panel or restriction orifice unit. It functions to trip the water control valve following actuation by a thermostatic or manual release. Normally, air pressure in the upper chamber (A, in Fig. 268) and the lower chamber (B, in Fig. 268) is equalized through a restriction orifice (8, in Fig. 268). When a release operates, pressure in the lower chamber drops suddenly; the plunger (10, in Fig. 268) causes the trip lever (16, in Fig. 268) to pivot and release a weight (19, in Fig. 268). The weight strikes a plunger (23, in Fig. 268), breaking a glass strut which allows air to exhaust to atmosphere.

The dehydrator (Fig. 269) is used on pneumatic release systems which are exposed to freezing conditions. The unit includes a cast iron body (1, in Fig. 269) which contains a perforated metal cartridge (3, in Fig. 269) filled with a dehydrating agent (5, in Fig. 269).

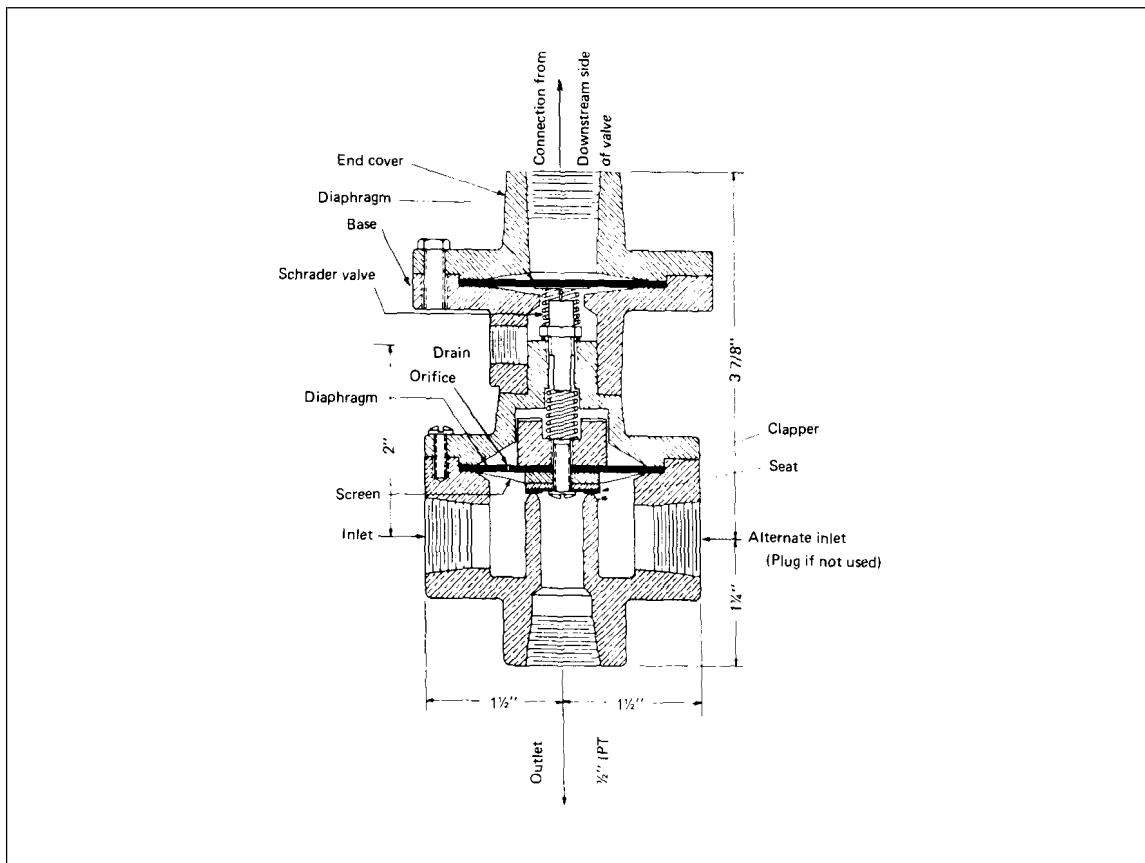

Fig. 260. Model C1 pressure-operated relief valve.

The anti-water-columning device (Fig. 263) is used in hydraulic release systems when necessary to prevent water columning of the water control valve. Normally, release system pressure acts on the diaphragm (2, in Fig. 263) to hold the valve (3, in Fig. 263) on its seat and prevent flow to drain. Operation of a release in a fire reduces pressure on the diaphragm and allows the valve to lift. Water then flows from the pressure chamber (C, in Fig. 263) to drain faster than it can be supplied through the restricted orifice (2, in Fig. 235), and the water control valve trips. The spring (5, in Fig. 263) is adjusted so that the valve will open at a pressure 20% higher than that of the water column in the release system.

The Model C1 pressure-operated relief valve (Fig. 260) must be used in conjunction with the Model C1 release to prevent resetting of the water control valve if the Model C1 release compensates and automatically resets. Upon operation of the water control valve, pressure is applied to the upper diaphragm from the downstream side of the water control valve. This pressure (approximately 5 psi) forces the diaphragm down so that the Schrader valve opens to vent the chamber above the lower diaphragm. This allows the diaphragm assembly to rise which continually exhausts the pressure from the top of the water control valve, thereby preventing it from closing.

OPERATION

When Fire Occurs. With a hydraulic release system on deluge sprinkler systems (Fig. 237 and 258), heat acts on the thermostatic releases so that they operate and drain off water from the release system faster than it can be replaced through the restriction orifice in the deluge valve trim. Pressure in the pressure chamber of the deluge valve is reduced and the deluge valve trips. Manual operation is by pulling the emergency trip valve lever (15, in Fig. 237; 14, in Fig. 258) or by the remote control (5, in Fig. 237; 19 in Fig. 258).

With a pneumatic release system (Fig. 255, 256, 261 and 262) on a preaction or deluge system, heat acts on the thermostatic releases causing them to operate and release air from the system. The diaphragm bypass valve opens and water from the pressure chamber of the water-control valve drains off faster than

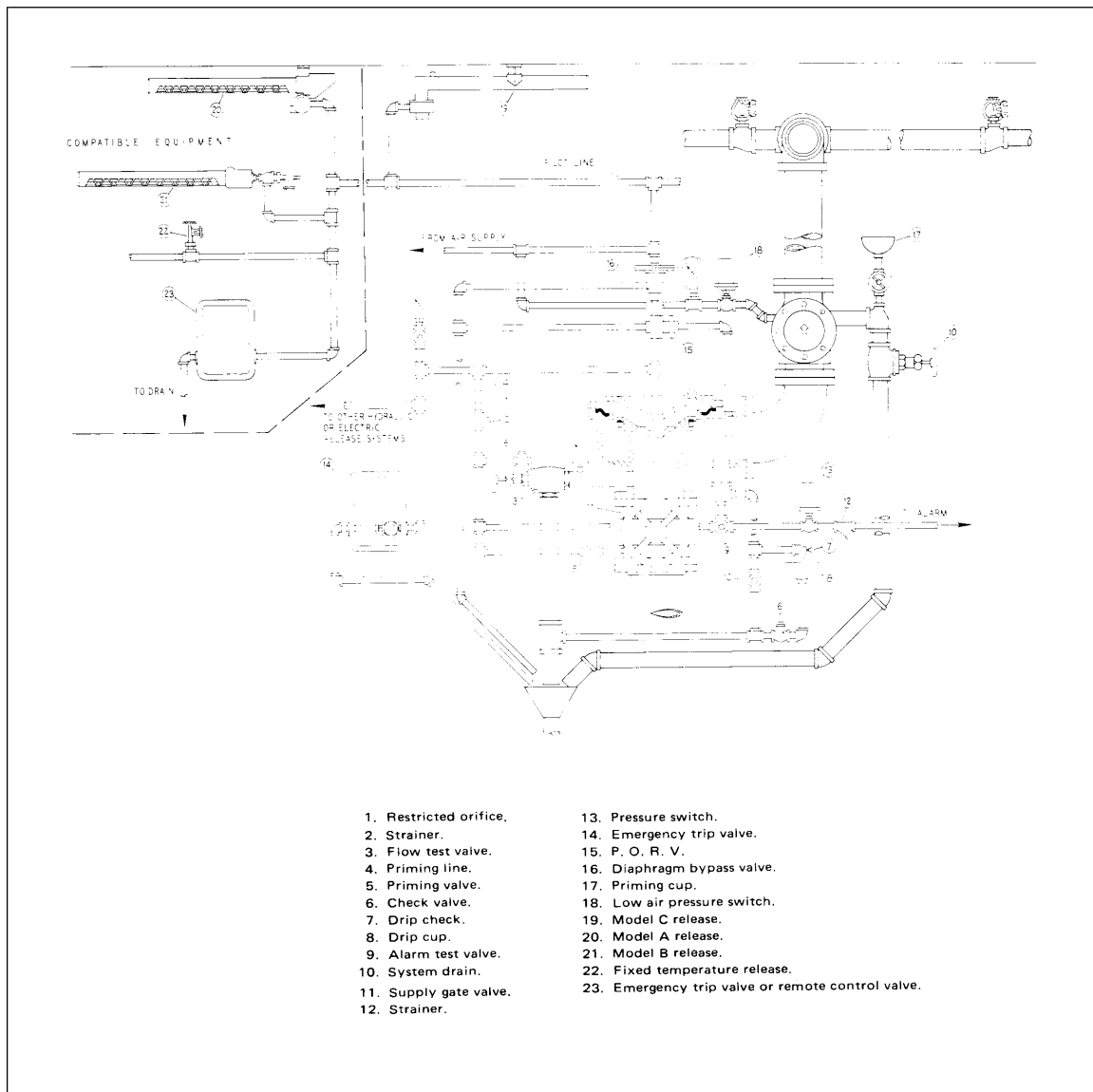

Fig. 261. Preaction sprinkler system - pneumatically operated with Model C thermostatic release.

it can be replaced through the restriction orifice in the water control valve trim. The clapper lifts and water flows to the sprinkler system. If Model C1 thermostatic releases are used, the pressure-operated relief valve operates to continually exhaust the pressure chamber of the water-control valve.

Leakage of Supervisory Pressure. In a hydraulic release system (Fig. 237 and 258), leakage will permit water to flow into the water control valve pressure chamber through the restriction orifice (2, in Fig. 237). If the leak exceeds the capacity of the orifice, the pressure chamber loses pressure and the water-control valve trips.

In a pneumatic release system (Fig. 255, 256, 261, and 262), leakage will permit air to flow through the restriction orifice in the air supply line into the system. If the leak is large enough, pressure in the release system will drop. A pressure switch (23, in Fig. 255 and 256; not shown in Fig. 261 and 262) will sound a trouble alarm at 10 to 15 psi. Another pressure switch (21, in Fig. 255 and 256; not shown in Fig. 261 and 262) will start a compressor when air tank pressure drops to 20 psi and will shut it off when the pressure reaches 40 psi. If a large leak continues, pressure is reduced on the diaphragm bypass valve (6, in Fig. 255 and 256; 16 in Fig. 261; and 15, in Fig. 262) to a point where it operates and trips the water control valve.

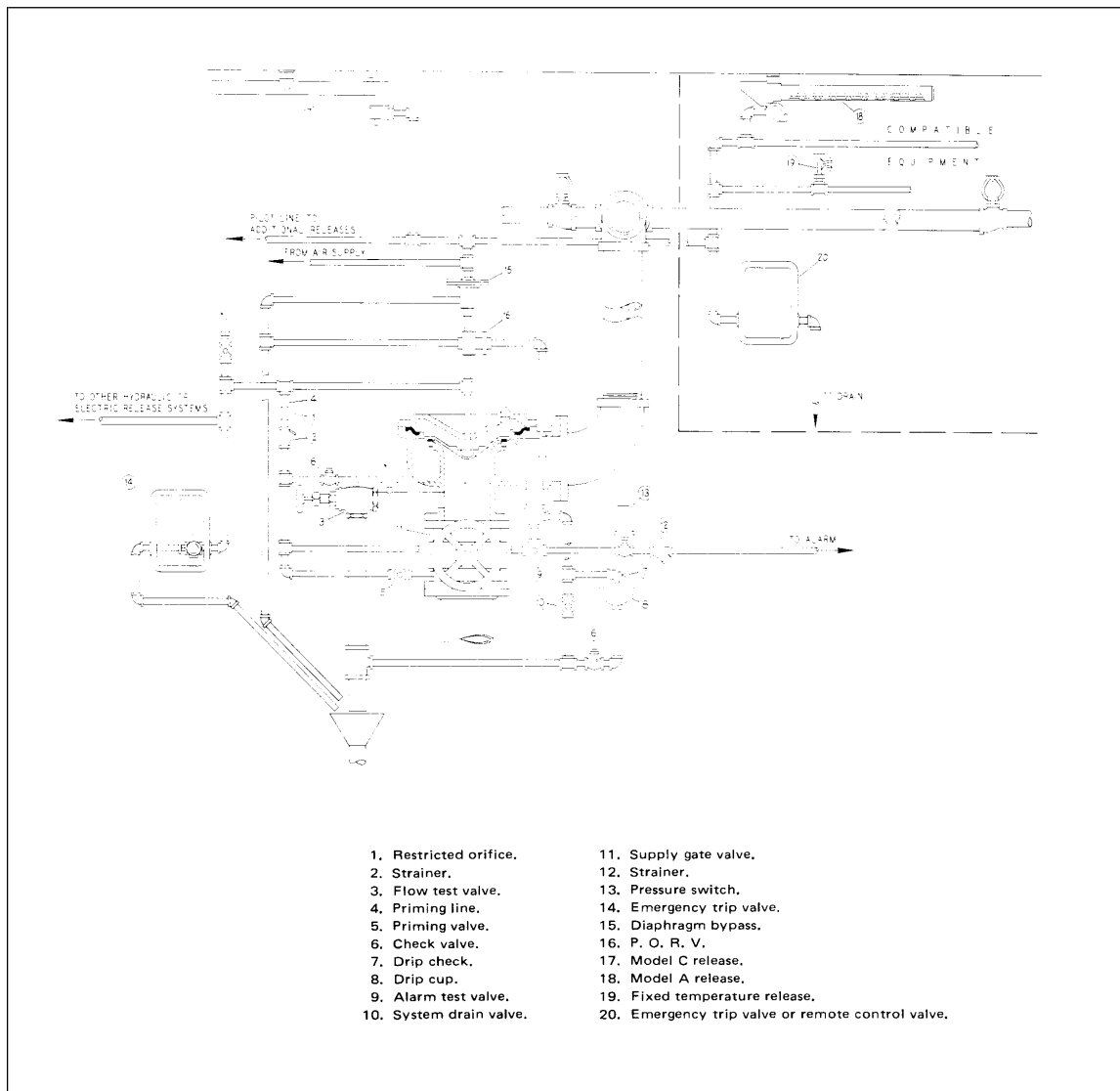

Fig. 262. Deluge system, pneumatically operated, with Model C thermostatic release.

In the sprinkler piping of a preaction system (Fig. 256 and 261), leakage will cause the air pressure maintenance device (26, in Fig. 256; not shown in Fig. 261) to admit air from the supply source. If a leak exceeds the capacity of the device, pressure will drop in the piping sounding the trouble alarm, at 10 to 15 psi. A pressure switch (21, in Fig. 256; 18, in Fig. 261) will start the compressor (20, in Fig. 256) to restore the air supply when the pressure drops to 20 psi.

SETTING

Refer to Fig. 237, 258, 262, 256 and 261.

1. Close the main OS&Y valve (11, in Fig. 237, 258, 262, 256 and 261) controlling the system. Shut off the air compressor or other air supply of pneumatic release systems.
2. Open the valve of the 2-in. test drain (13, in Fig. 237, 255 and 256; 3, in Fig. 261 and 262) below the automatic water-control valve and the system drain valve (12, in Fig. 237, 255 and 256; 10, in Fig. 261 and 262). In a supervised preaction system, also open the system drain valve above the check valve (31, in Fig. 256).
3. Flush the water seat of the water control valve; the clapper is self-seating. In a supervised preaction system, remove the cover from the check valve, clean the seat and rubber facing, and replace the cover.

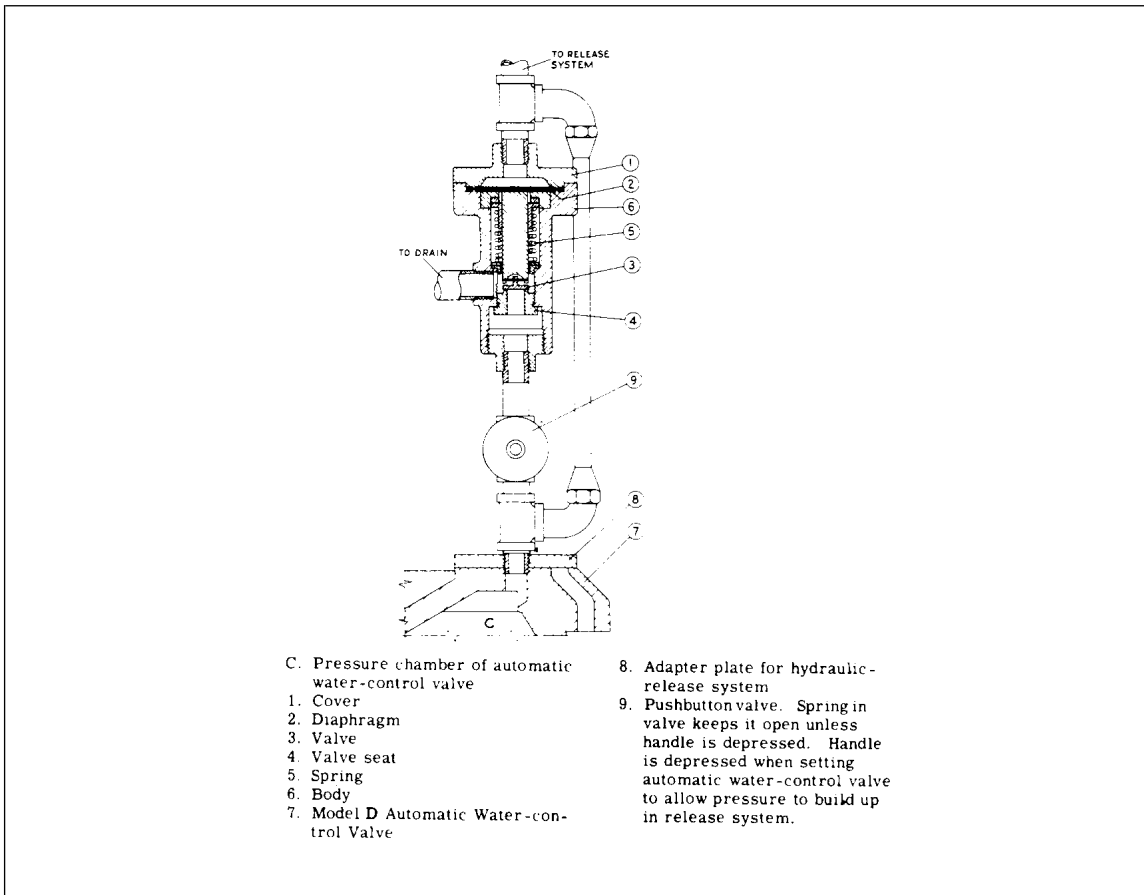

Fig. 263. Anti-water-columning device. Used to prevent water columning in hydraulic-release systems (shown with pressure in release system).

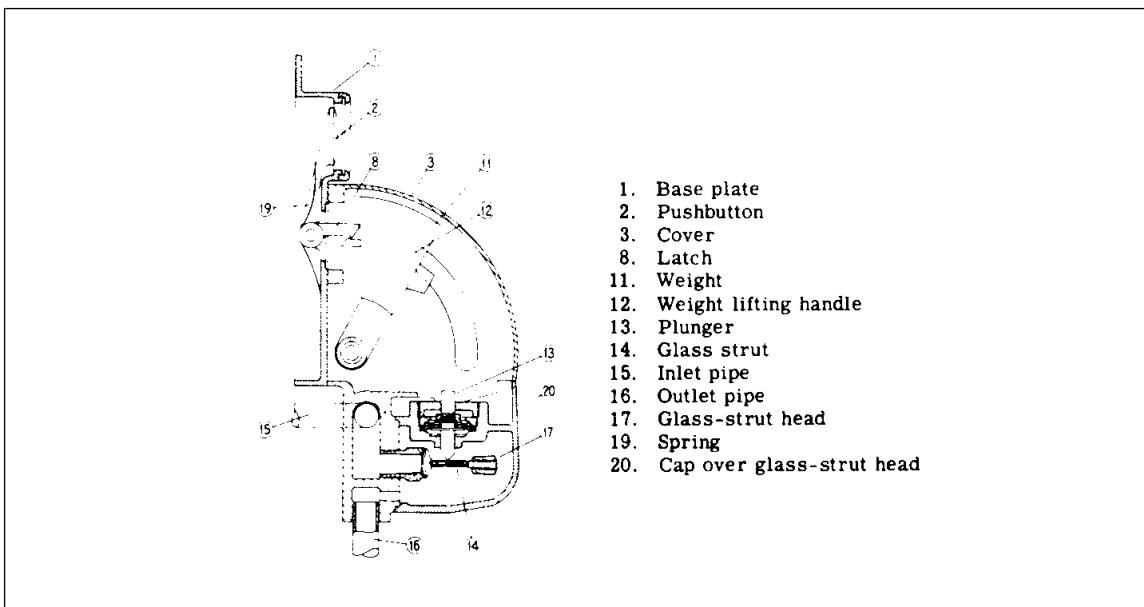

Fig. 264. Type A remote manual control. For use in hydraulic or pneumatic release systems.

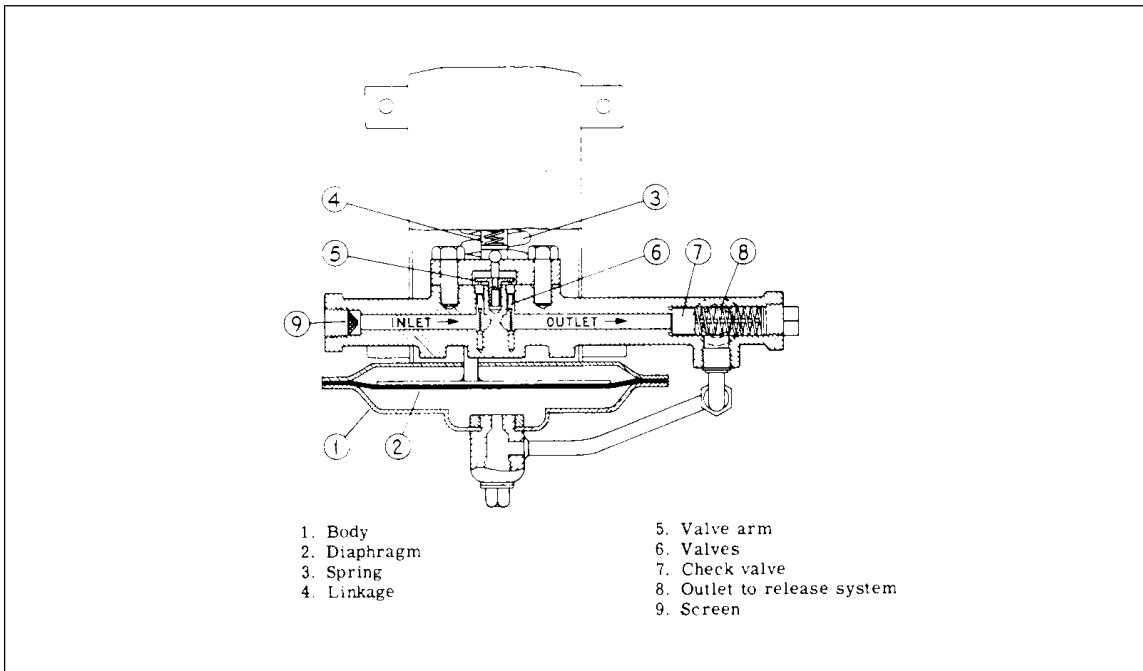

Fig. 265. Model C air-pressure maintenance device. Used when air supply is from a plant air system. Shown with no pressure on outlet.

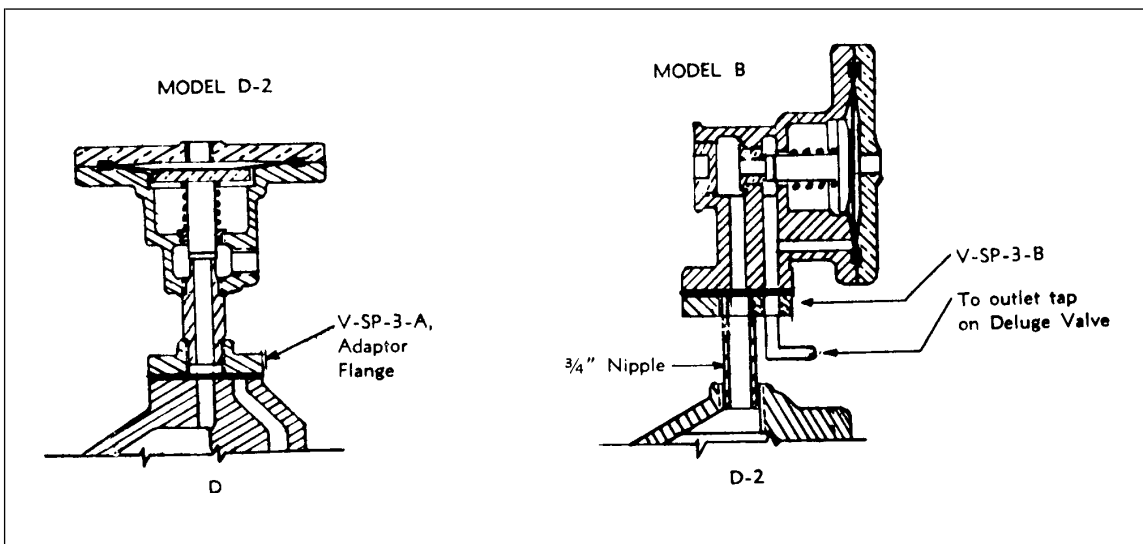

Fig. 266. Conversion of Model D and D2 valves with Model B and D2 bypass valves.

4a. With hydraulic release systems, open the priming valve (19, in Fig. 237; 5, in Fig. 258) to build up pressure in the water control valve pressure chamber. When equal to that of the water supply, slowly open the main OS&Y valve until water flows freely through the 2-in. test drain valve. Turn the OS&Y valve to full-open position.

4b. With pneumatic release systems, turn on the air compressor or other air supply. Reset the diaphragm relief valve by raising the reset lever. This allows air pressure to build up in the release line and close the diaphragm bypass valve. The pressure-operated relief valve automatically resets when the downstream pressure falls below 5 psi and so does not require resetting. When air pressure reaches normal, open the priming valve and allow water pressure to increase to normal in the water-control valve pressure chamber. Open the main OS&Y valve slowly until water flows freely through the 2-in. test drain, then slowly close the

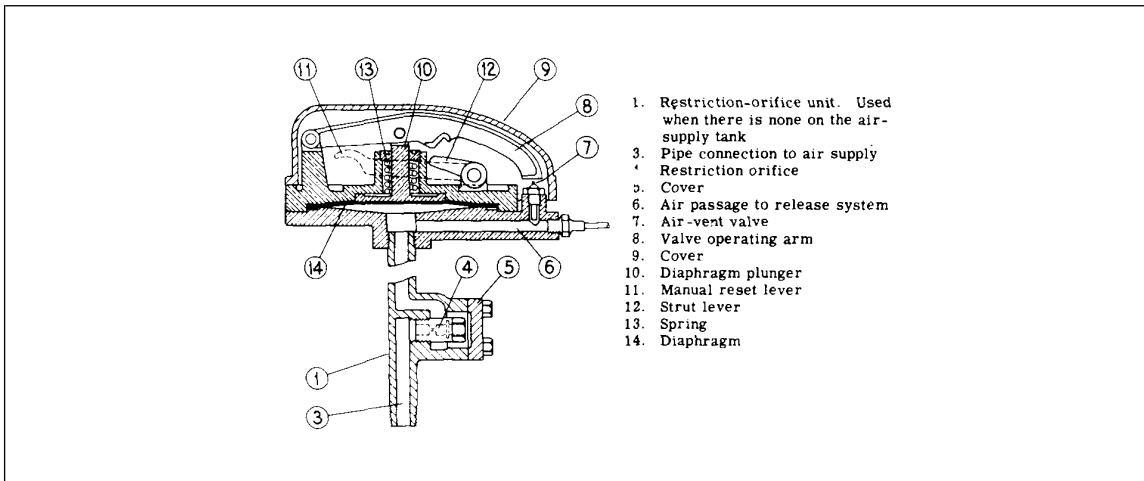

Fig. 267. Diaphragm relief valve. For pneumatic Type B release system.

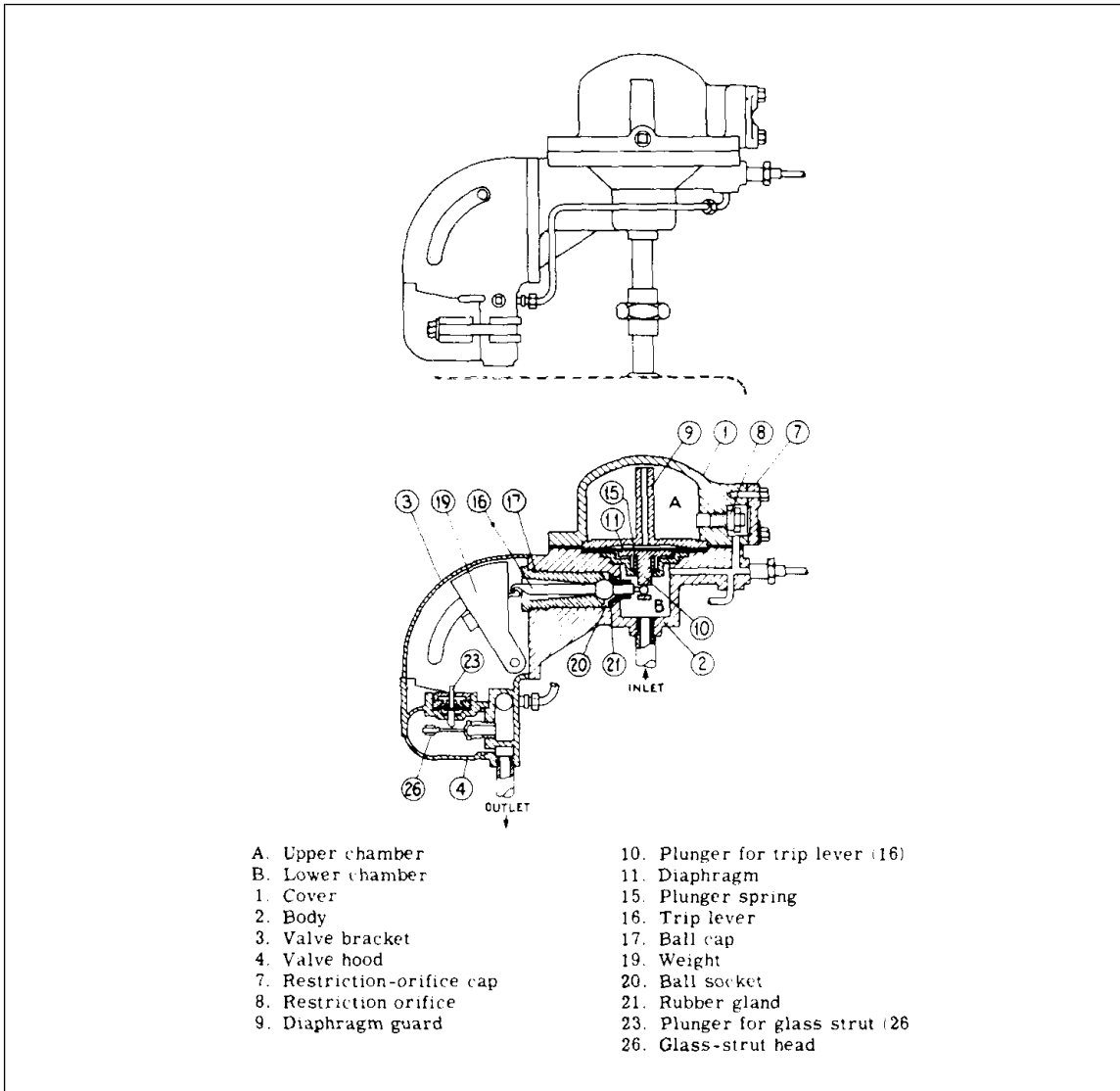

Fig. 268. Release line accelerator. May be used to replace the diaphragm relief valve on pneumatic systems.

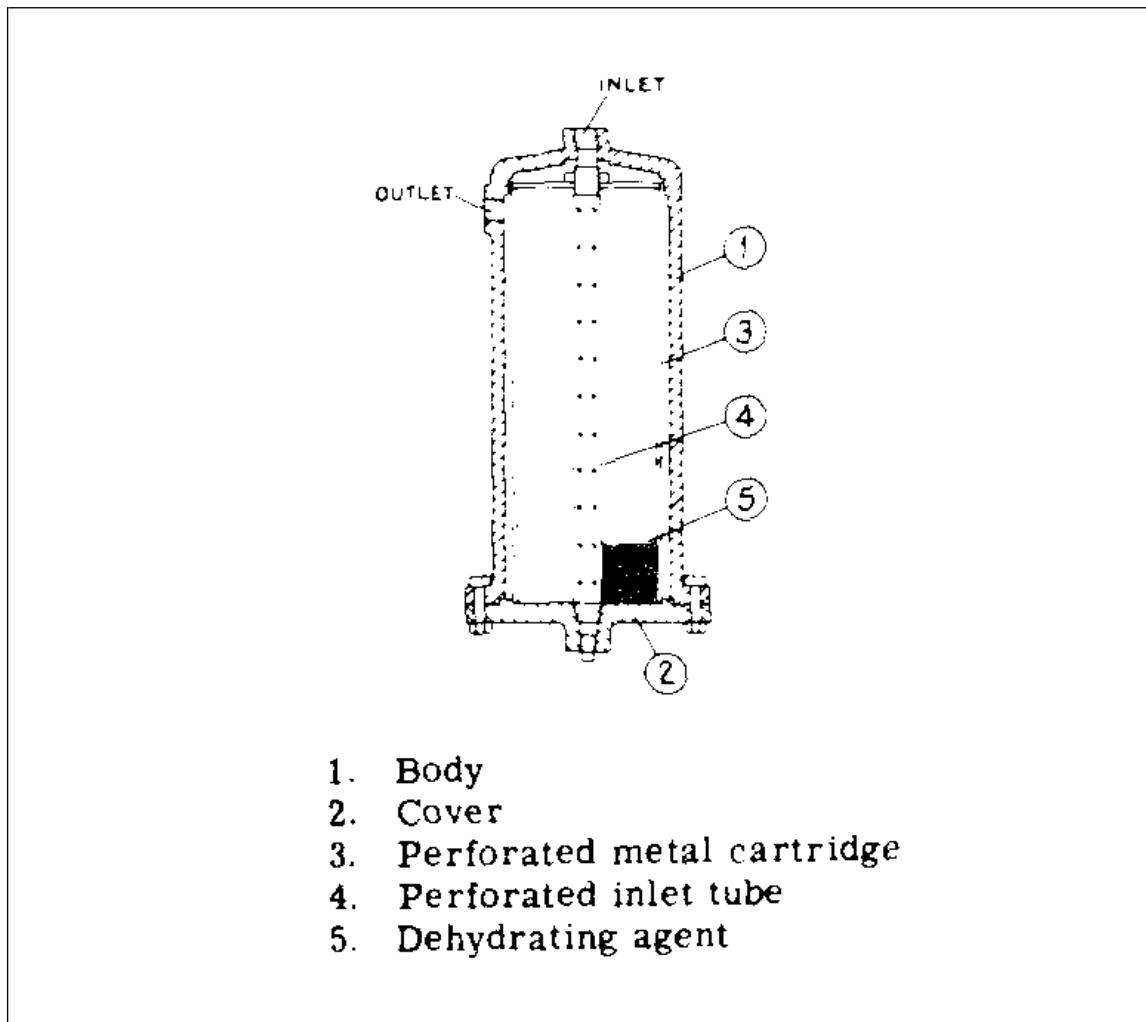

Fig. 269. Dehydrator. For use on pneumatic release systems exposed to freezing.

drain valve. Turn the OS&Y valve to a fully open position.

5. Close the system drain valves and the priming line valve.

6. Make a full-flow check using the 2-in. test drain to ensure that all manual control valves are open; then lock them in the wide open position. The system is now in service.

MAINTENANCE AND INSPECTION

Deluge and preaction systems require careful maintenance, inspection, and testing by specially trained personnel. Unless a plant has specialists available, it is advisable to purchase the services under a contract arrangement with a system manufacturer or installer.

Only minor, readily apparent adjustments should be made by personnel other than specialists.

Make inspections and tests in accordance with the following minimum frequency schedule. In advance, notify the public fire department or other agency which may receive signals during any test.

Weekly. Test the water-motor alarm and trouble alarm. In pneumatic release systems, read the gage to be certain that air pressure is normal.

Monthly. Inspect all manual sprinkler control valves to be certain they are wide open and locked.

Every Four Months. With pneumatic release systems, check supervisory air as outlined below:

1. Read the gage to see that air pressure is normal.
2. Close the manual OS&Y sprinkler control valve.
3. Open the 2-in. test drain.
4. Operate the remote manual control (5, in Fig. 255 and 256).
5. Note that pressure in the release line drops, the diaphragm bypass is now open, and pressure in chamber "C" of the water control valve drops to zero.
6. Reset according to directions. Leave all manual sprinkler control valves open and locked.

Annually. Trip test the automatic water control valve using the following procedure:

1. In a preaction system, release supervisory air in the sprinkler piping system using the inspector's test connection at the end of the system. Note that the air compressor starts and the trouble alarm sounds at the proper pressures. Close the valve quickly when a trouble alarm sounds to avoid unnecessary loss of air.
2. In all systems, close the main manual OS&Y sprinkler control valve. Then open the 2-in. test drain below the water-control valve.
3. Apply the electric test set to one of the thermostatic releases in each group. Note that operation occurs within one minute. Where use of an electric test set would create a hazard, use a hot water test gun or a steam jet.
4. With Type A thermostatic releases, replace the glass-strut head. With Type B thermostatic releases, wait a few minutes to allow them to cool and reset, and for pressure in the release system to return to normal. With Type C thermostatic releases, allow about 60 minutes for release to adjust to ambient temperature condition. Remove cover. Insert appropriate size feeler gage (refer to manufacturer's literature) as shown in Fig. 270. Tighten set screw until release operates. Remove feeler gage. Release is now set.

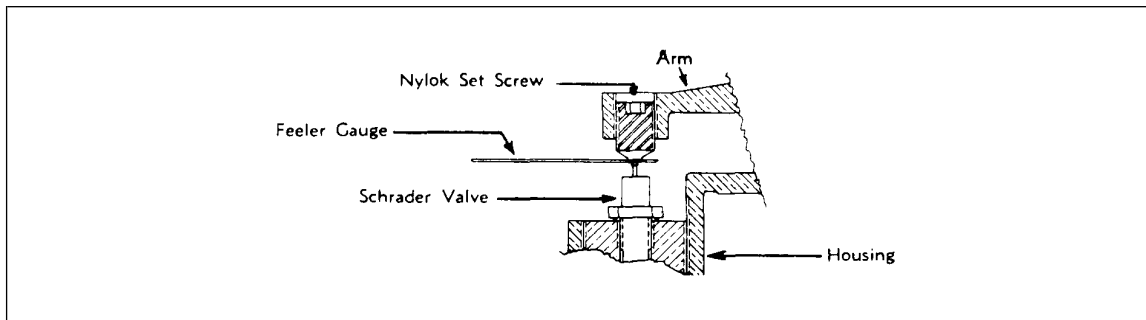

Fig. 270. Setting of Model C1 thermostatic release.

5. Operate the remote manual control. Note that the automatic water-control valve trips. Reset the remote manual control.
6. Operate the emergency trip valve observing that the automatic water-control valve trips.
7. Return the system to service according to directions in the section **SETTING** leaving manual sprinkler control valves open and locked.

Operation.

General.

1. The detector is selected with a proper vent orifice to compensate for normal ambient temperature changes. Similarly, the sprinkler head temperature is selected to suit the location.
2. With a detector installed in the pilot pipe line of a system, the reset latch level pin (I) is turned which latches the valve cap assembly onto its seat. The pilot line is then pressurized with either air or water.

Alarm Condition.

1. A fire, producing a rate of temperature rise which exceeds the pressure venting rate of the detector orifice, causes the bellows (3) to expand. Its attached push rod forces the linkage to pivot and rotate, causing the reset latch to disengage. The hinged valve cap assembly rotates free and releases the pressurized air or water in the pilot line and blows the cover cap (2) to one side. This reduction of pressure causes the deluge valve to operate.

2. If the sprinkler head (4) fuses first, the pilot line air or water is released through the sprinkler orifice.

Restoration of Detector Release Devices. All detector release units that operate during a fire should be tested with the following procedure. Refer to Figure 238.

1. Close main water supply valve to deluge valve.

2. Replace sprinkler head (4) in all operated release units.

3. Restore all detectors by turning the latch reset pin (1) with a screw driver $\frac{1}{4}$ turn. This will hold the valve cap assembly with rubber seat closed, i.e. on the vertical passageway from pilot line.

4. Position dust cover (2) on all release bodies.

5. If pilot line is dry, pressurize pilot line to operating pressure. If pilot line is wet, fill pilot line with air. (If an air line is not available, a small portable air compressor may be used to fill the pilot line.)

6. Hold heat source near heat collector chamber (3) of each release unit until release operates with the dust cover cap (2) being blown off the top of release body. This indicates that the soldered joints around the heat chamber have not failed and release unit is undamaged.

7. If a release unit fails to operate or has had a sprinkler head (4) with a rating of 286°F operate, the entire release unit must be replaced with a new unit.